

FITTING INSTRUCTIONS

Part Name/Description:

Part No: ATW01761
 ATW01759

Mazda BT-50 Dual Cab Nov 2011 to Sep 2020, Wildback Canopy
 Ford Ranger Dual Cab June 2013 to Current, Wildback Canopy

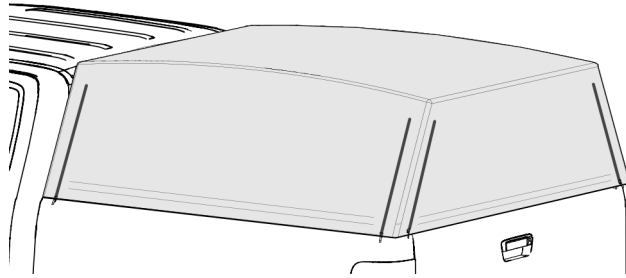

In the Box

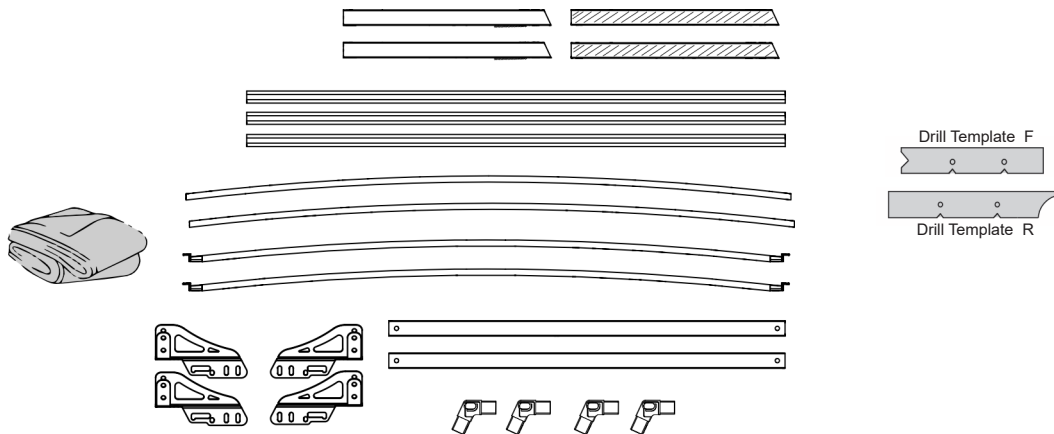

Hardware

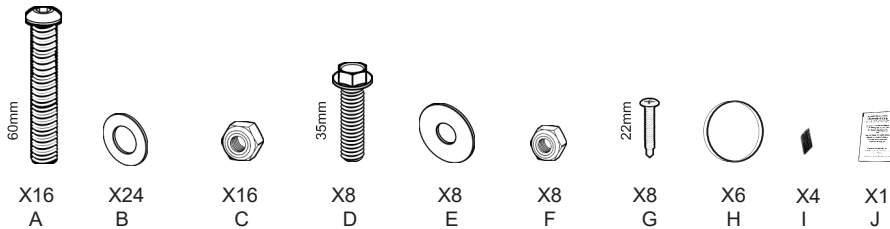

Tools Required

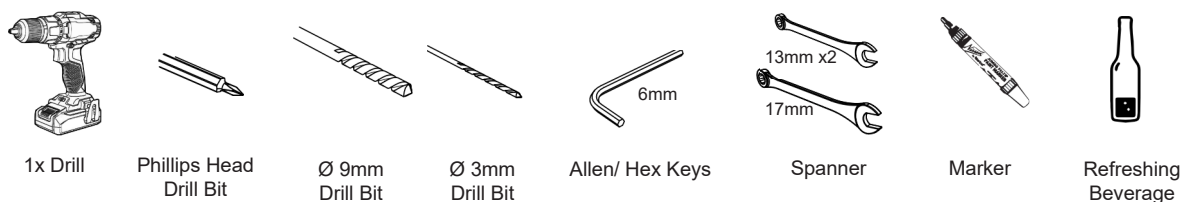

Any vehicle accessories which are not properly fitted, can be dangerous. Please read these instructions carefully prior to fitting and comply with the instructions at all times. If in any doubt please contact us e: sales@aussietonneaus.com.au

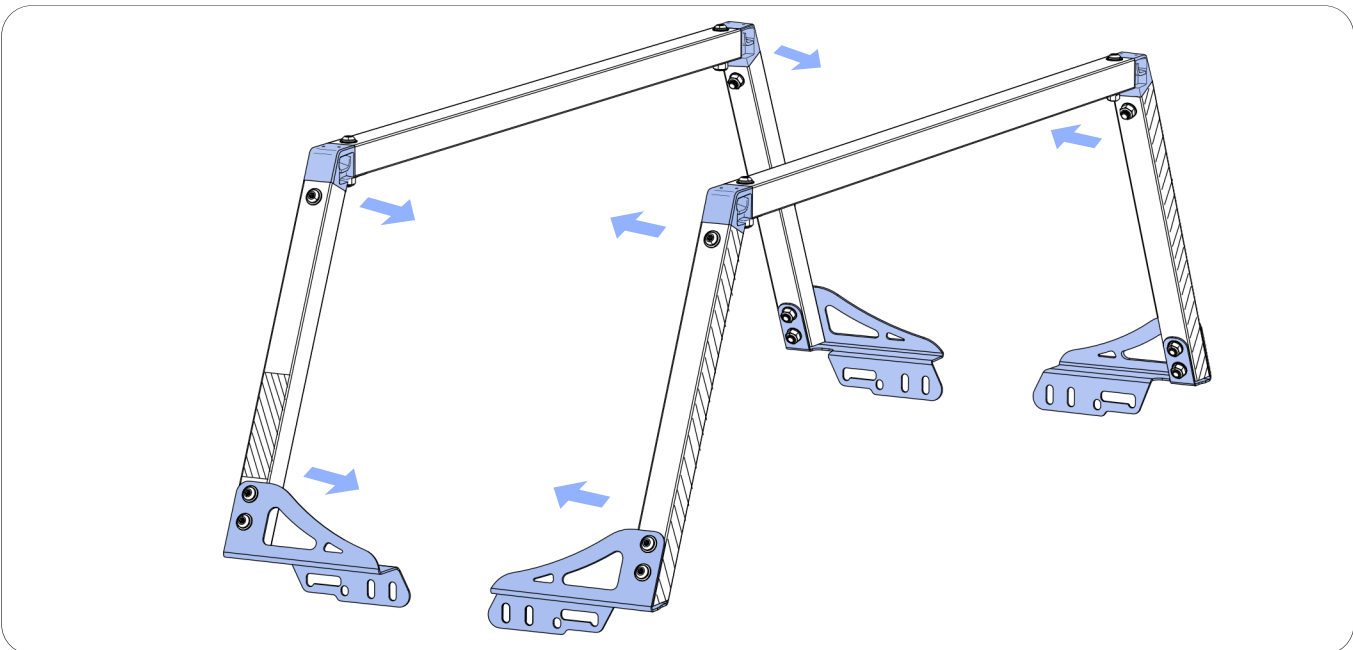
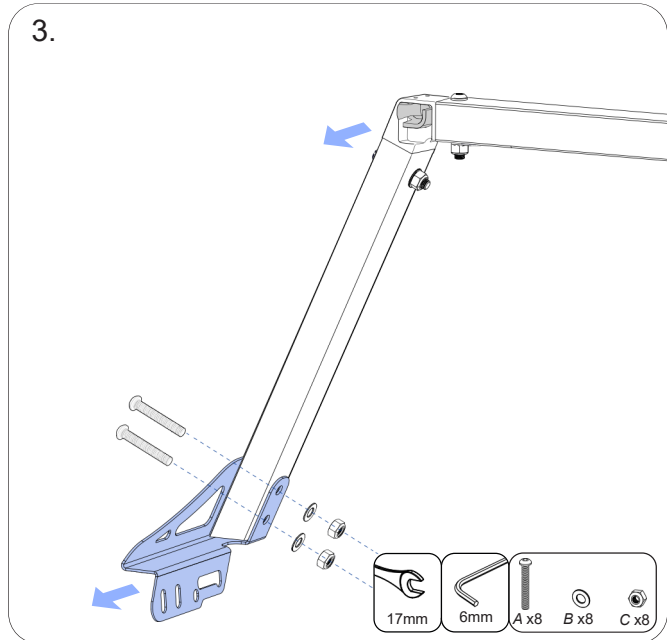
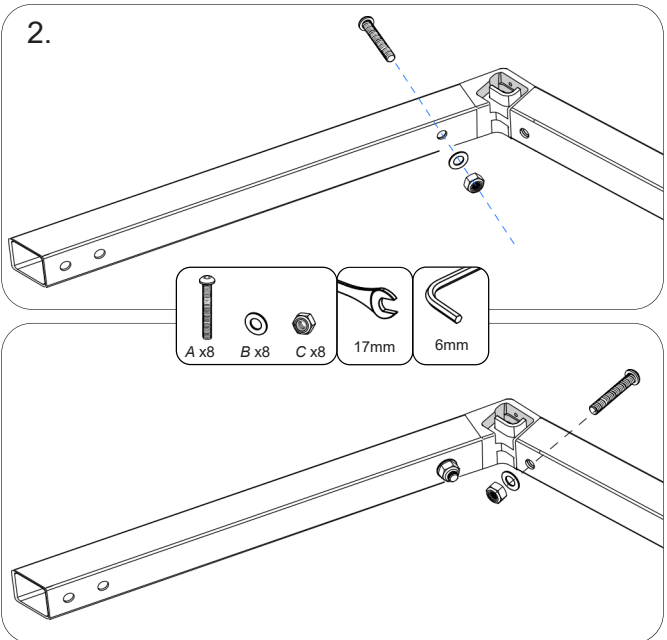
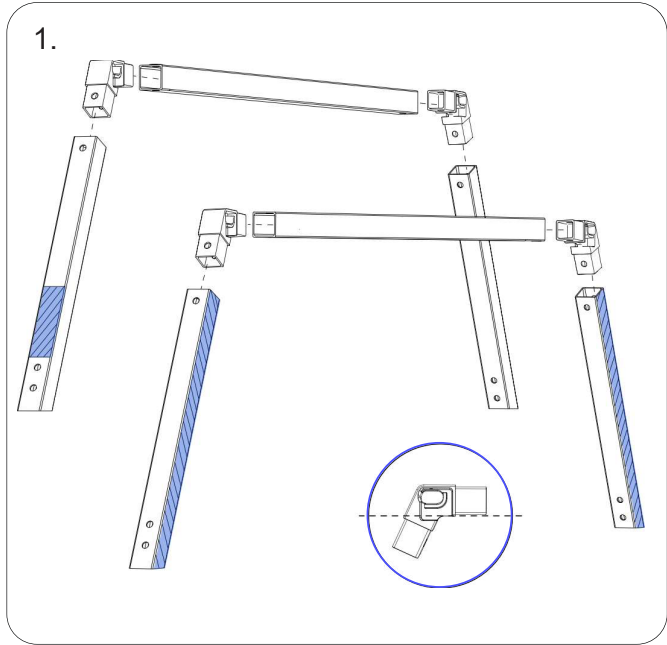
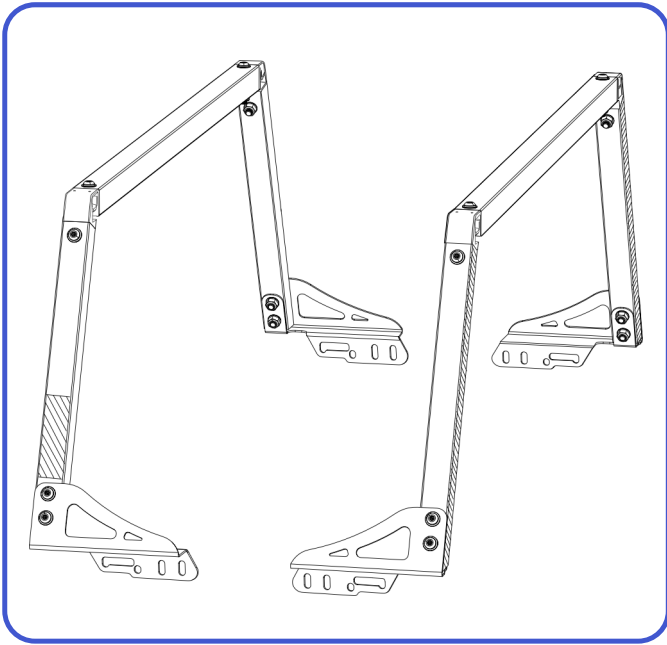

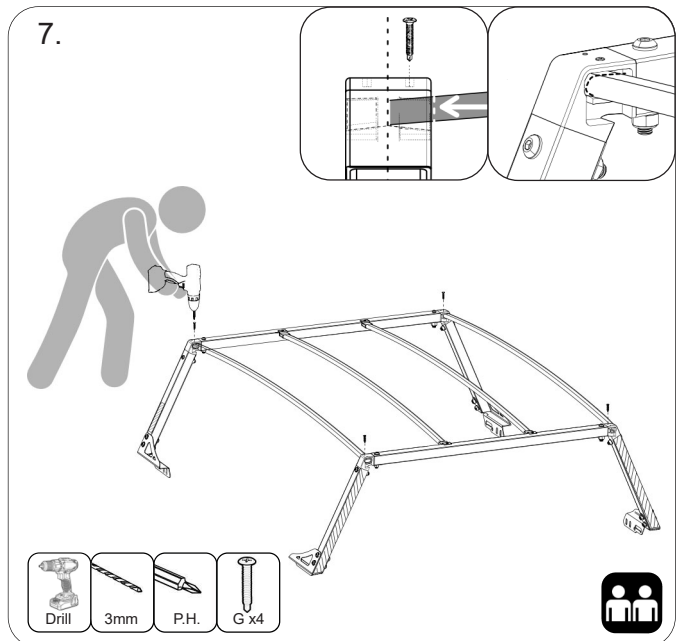
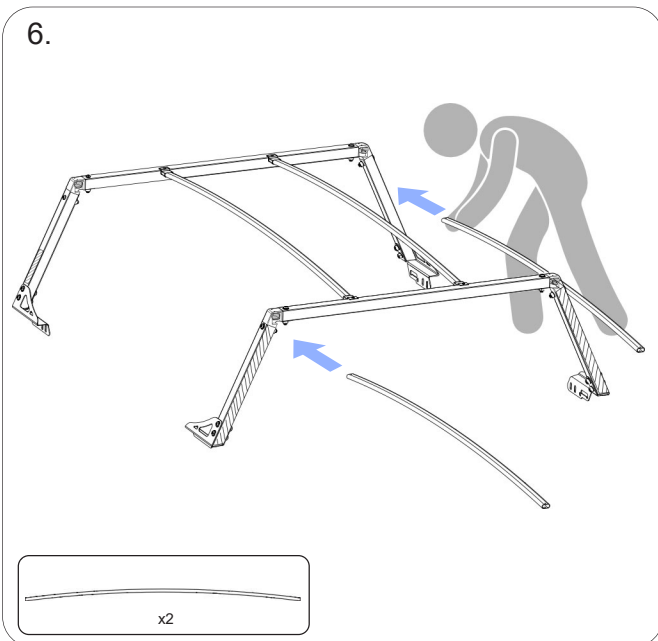
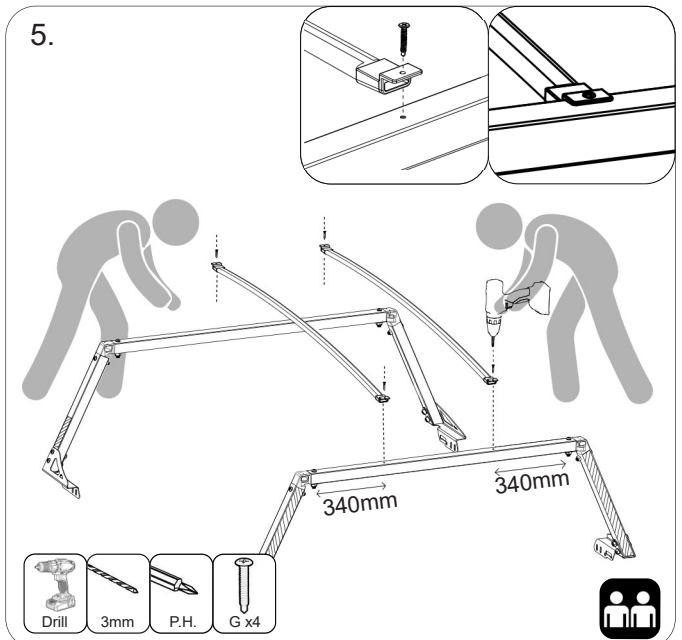
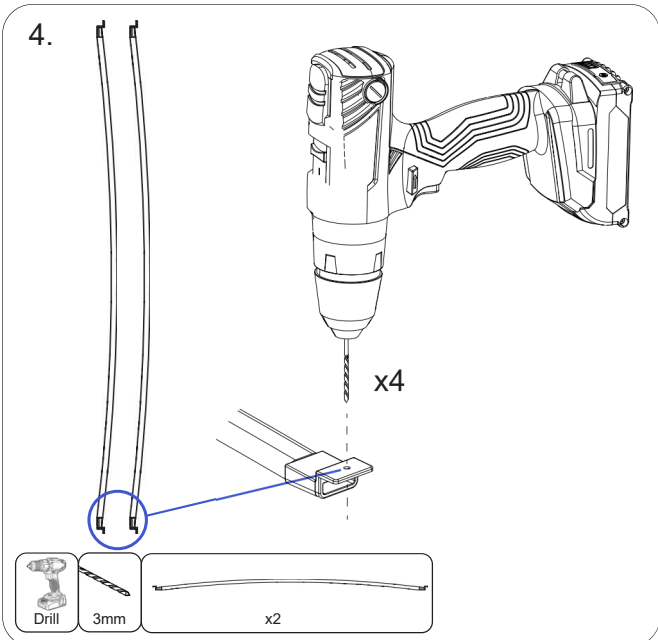
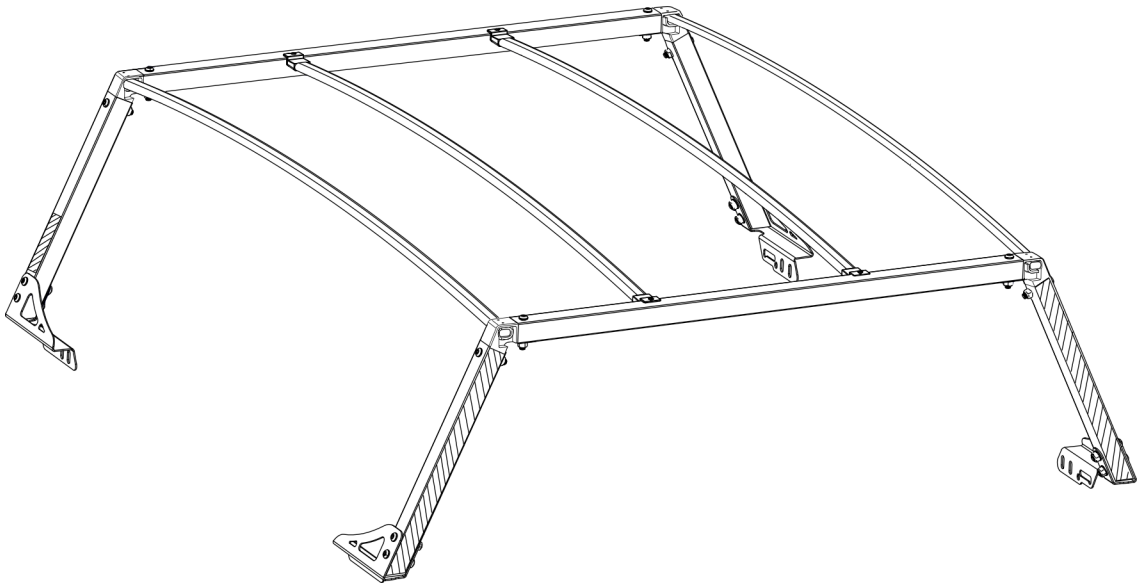

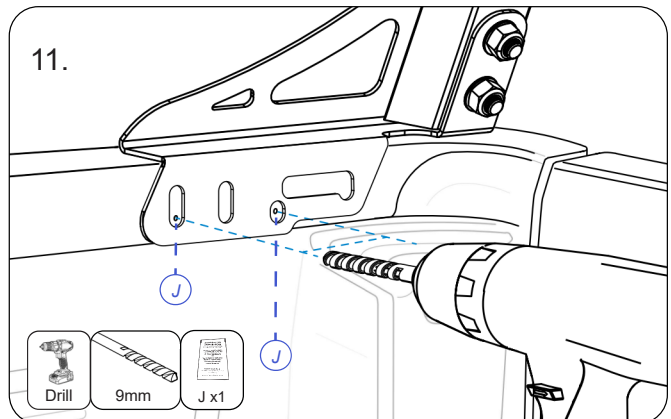
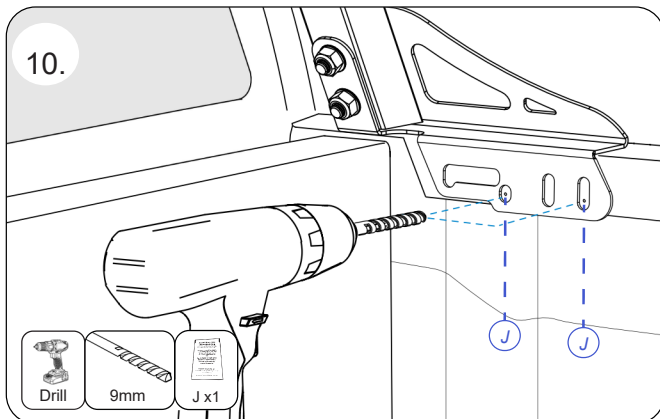
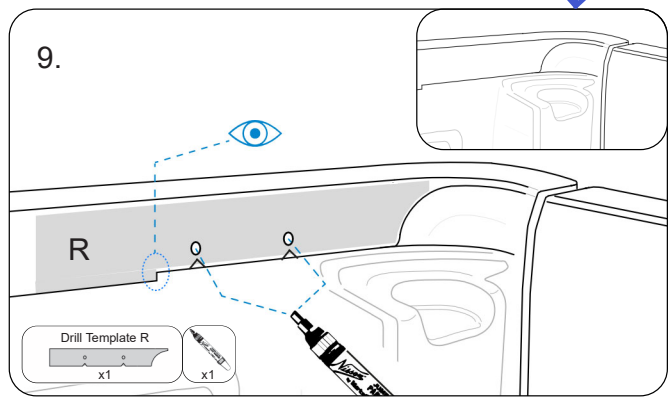
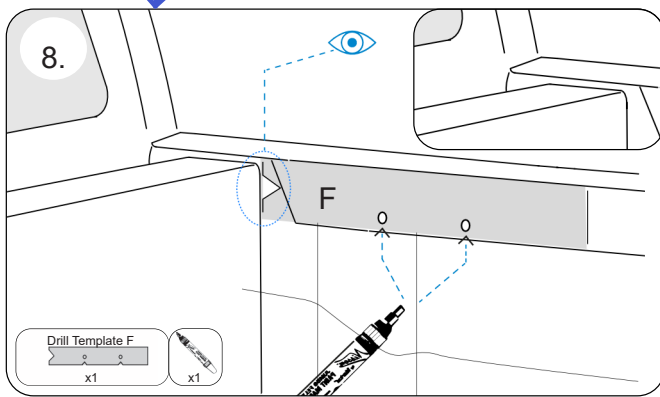
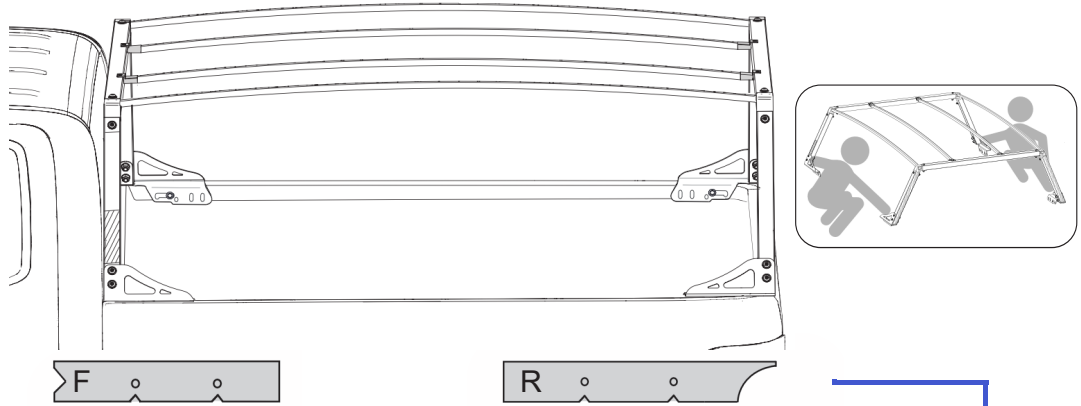
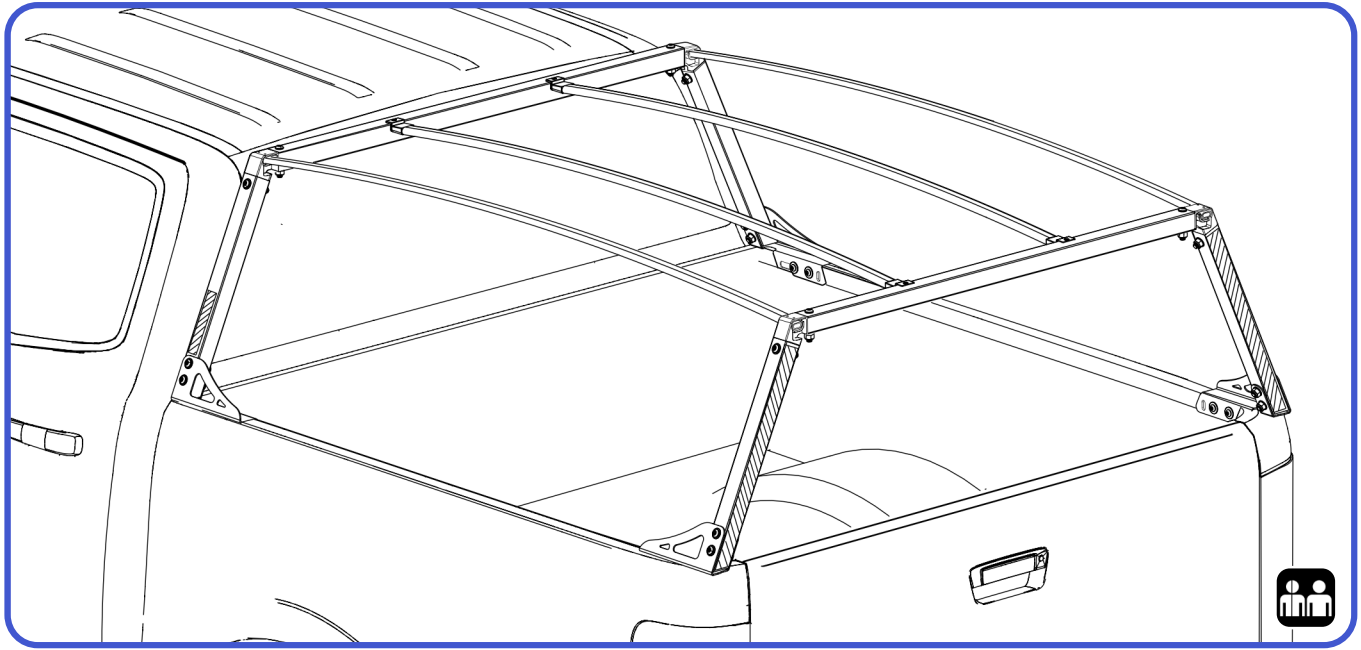

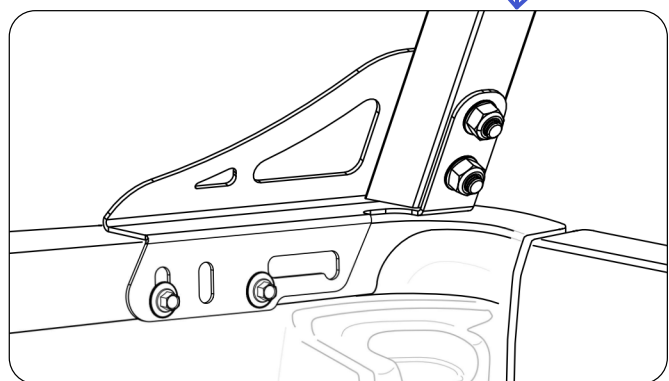
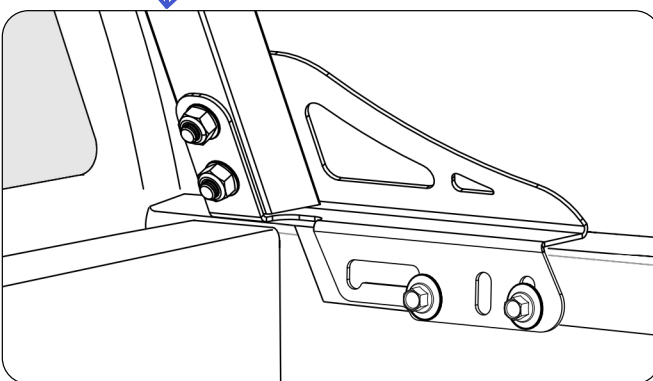
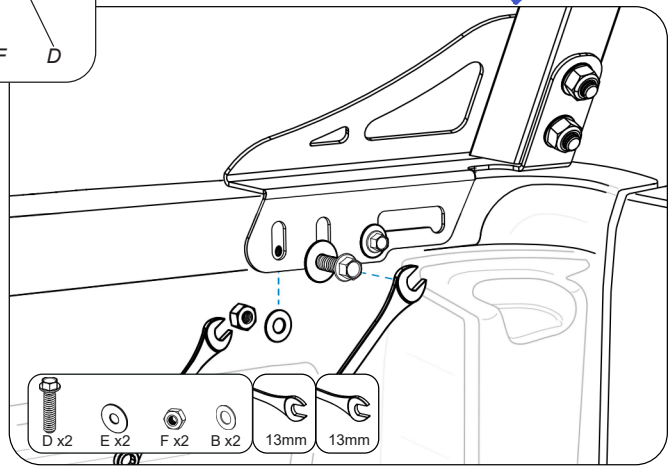
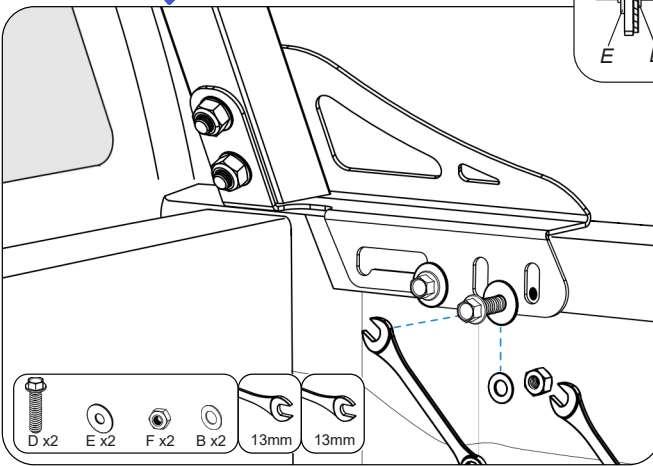
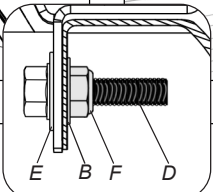
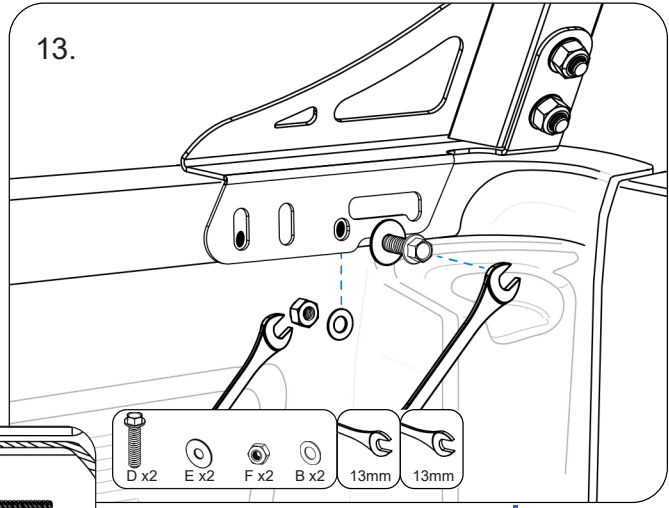
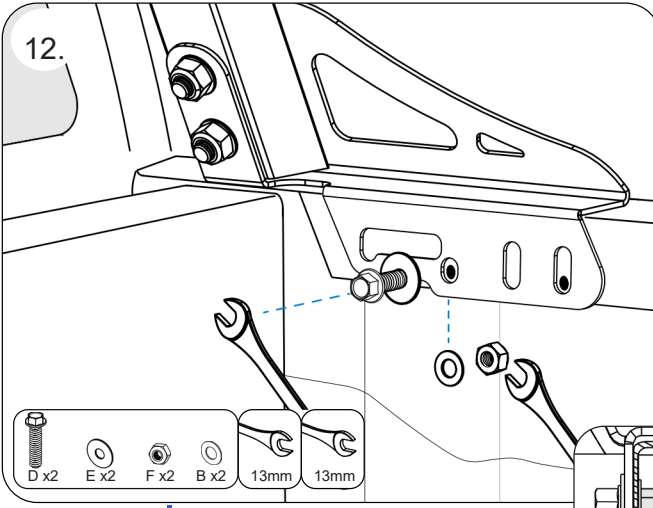
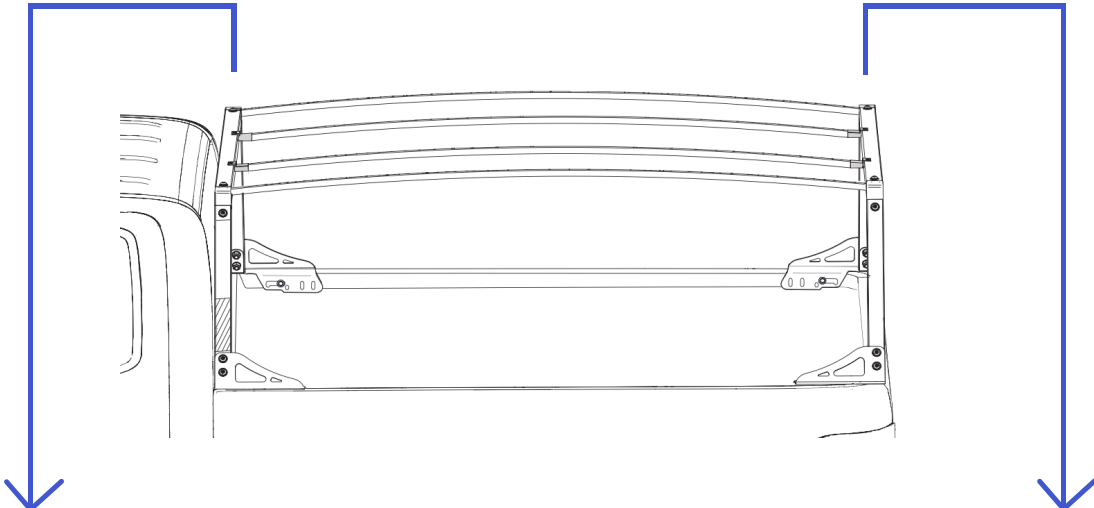

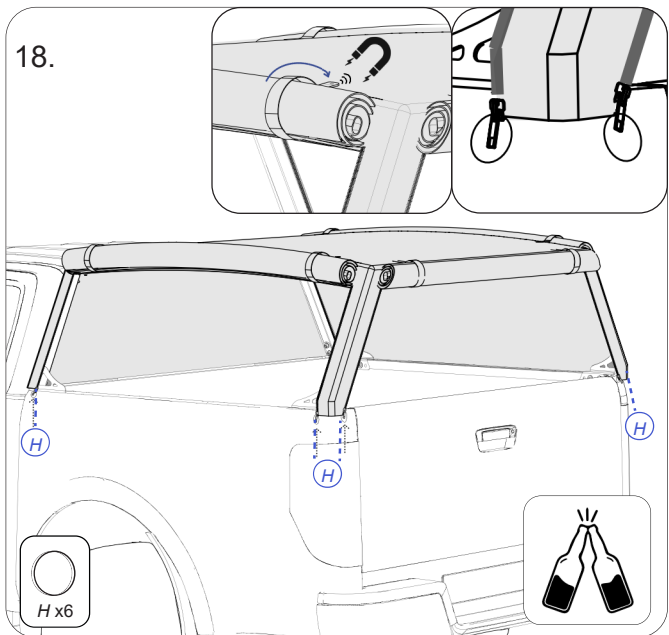
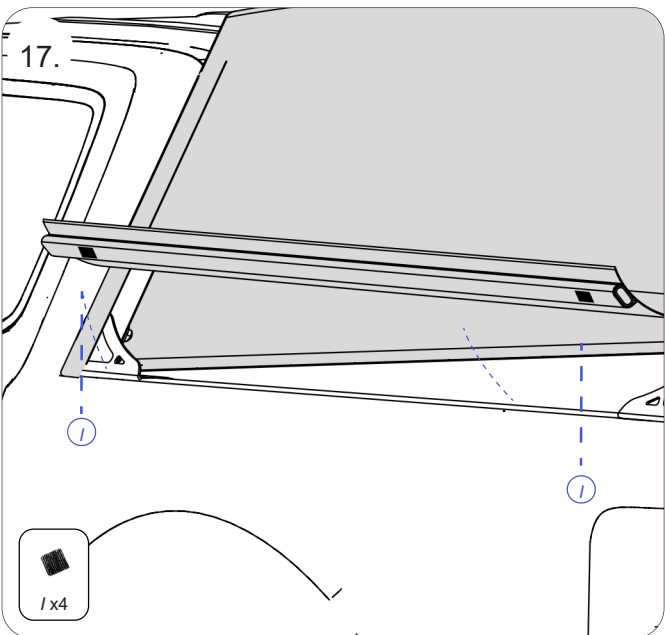
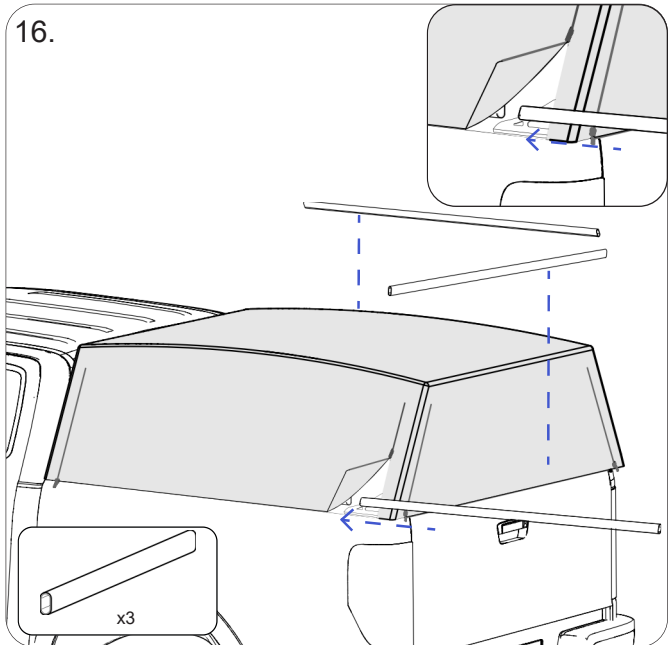
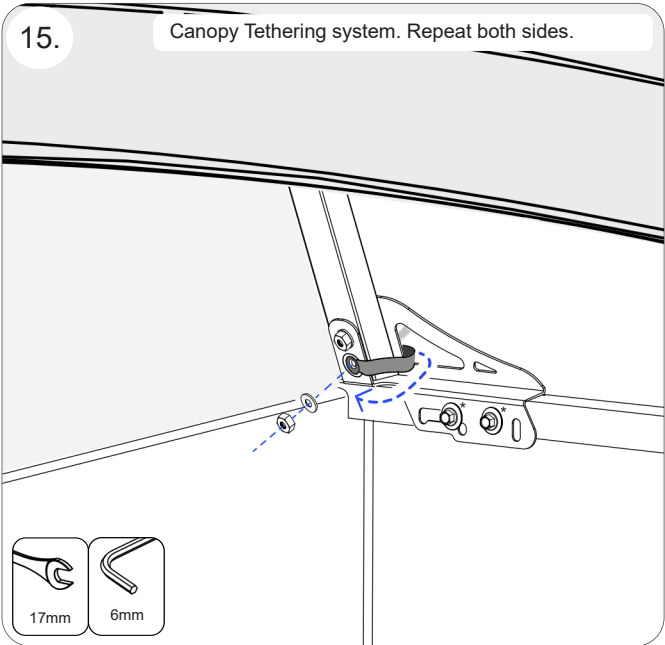
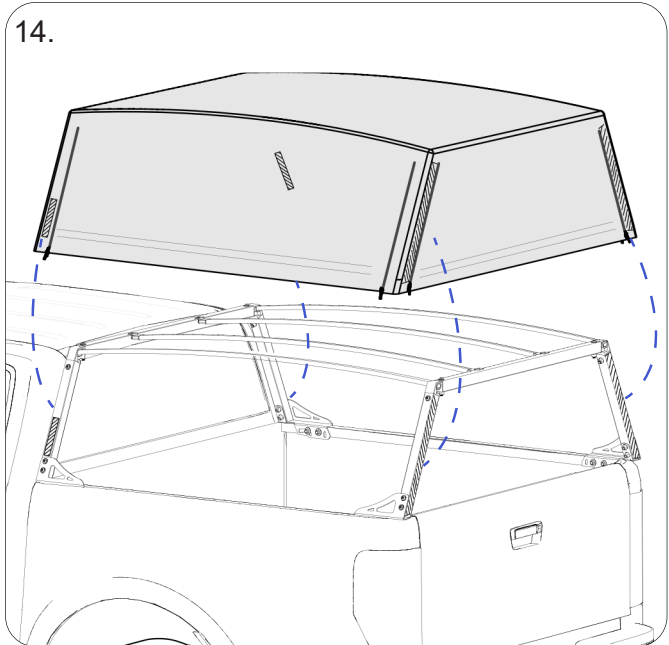
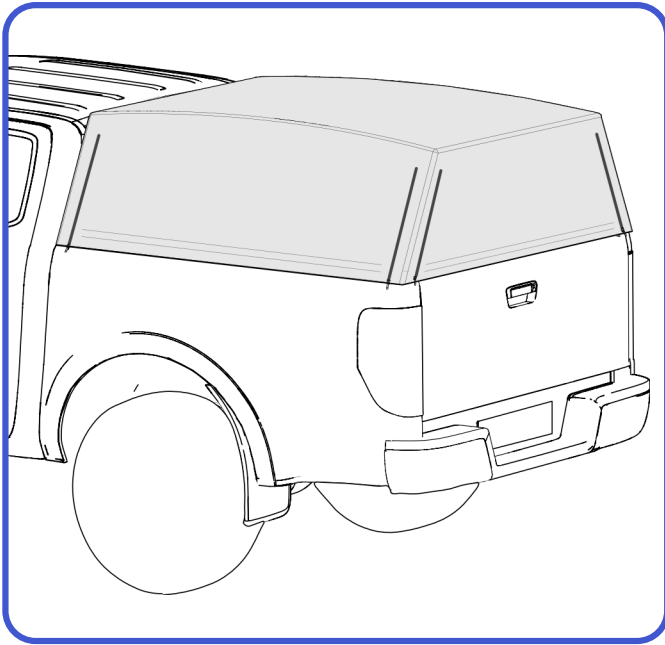

INSTRUCTIONS FOR USE

Send Us A Photo of your Wildback!

Happy with how your canopy turned out?

Please send us a photo to: sales@aussietonneaus.com.au



Safety

- Ensure the Canopy tethering system is installed correctly before driving.
- Regularly check the tightness of the fasteners.
- Load must be evenly distributed and adequately secured.
- Do NOT exceed 40kg load on Ladder Racks.
- Ensure the canopy is completely closed before driving.

Load carrying Requirements and recommendations

- The load must be evenly distributed over the area of the Ladder Rack system, and the center of gravity of the load kept as low as possible. Loads which overhang the ends of the carrier system must conform to any relevant laws or by-laws in your area, and shall be adequately secured.
- Loads must be adequately secured using suitable straps or similar tightening and locking devices. The security of the load and roof load carrier shall be checked after loading and regularly throughout the journey. Elastic straps must not be used. The user is warned to maintain and to use straps in working order.
- It is recommended that items which may produce significant lifting forces (surfboard, sailboard...) are carried in such a way that lifting force is minimized, securing them independently to the front and rear of the vehicle using straps or other methods which are capable of withstanding the lifting forces. Elastic straps must not be used.
- The handling characteristics of a vehicle (in particular crosswind sensitivity, handling on bends and braking) change when a carrier system is fitted and especially if that system is loaded. Driving techniques should be altered to allow for these changes, speed reduced, especially on bends, and braking distances made greater.