

## TRAY CANOPY - FITTING INSTRUCTIONS

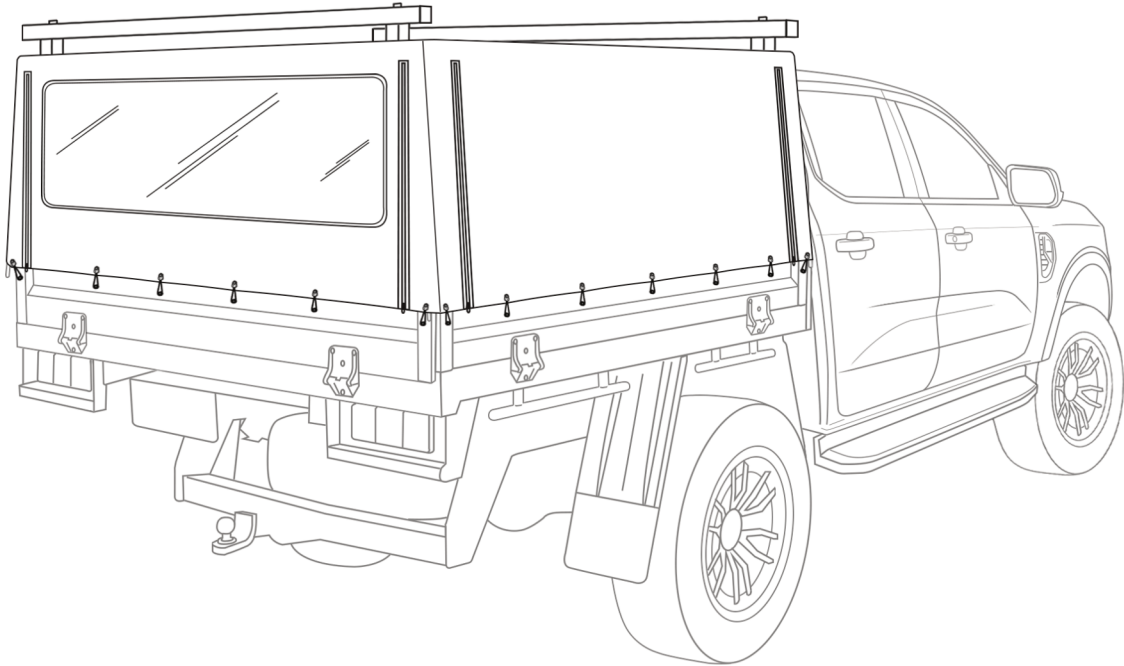

### Parts In the Box

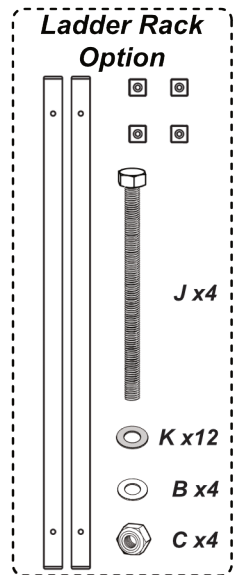
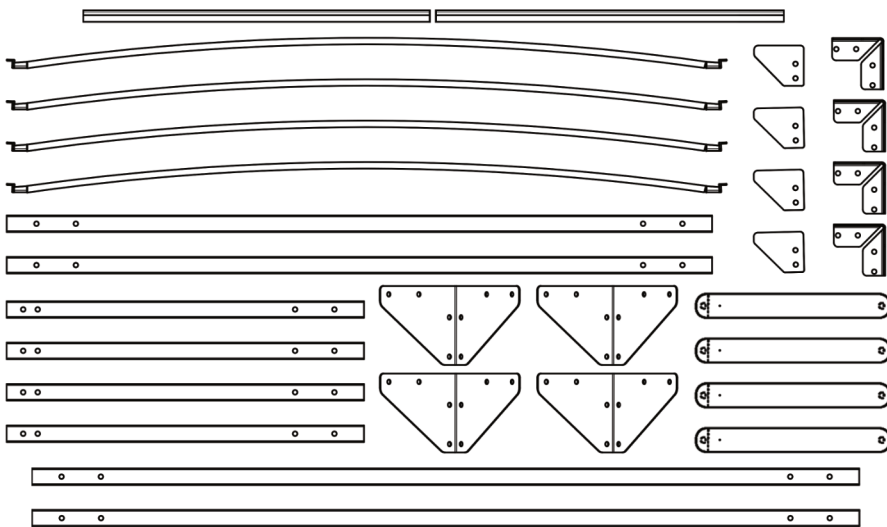

### Hardware In the Box

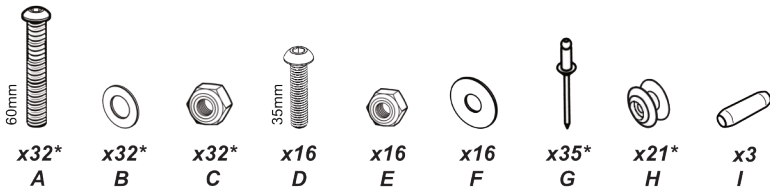

\*Extras will be supplied as required, based on tray size.

### Tools Required

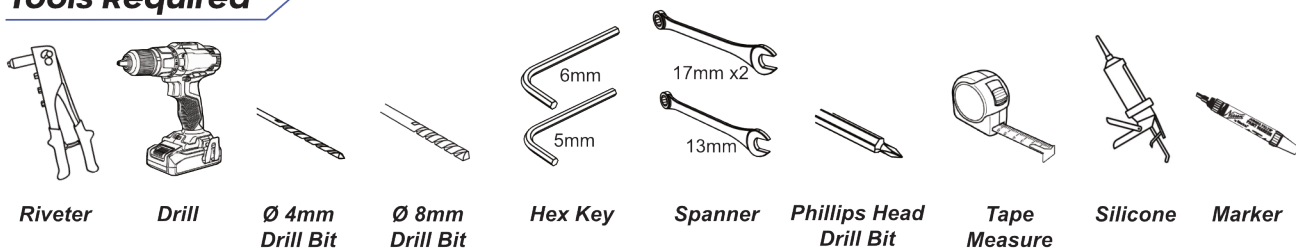

# 1. Attach the Rope Track

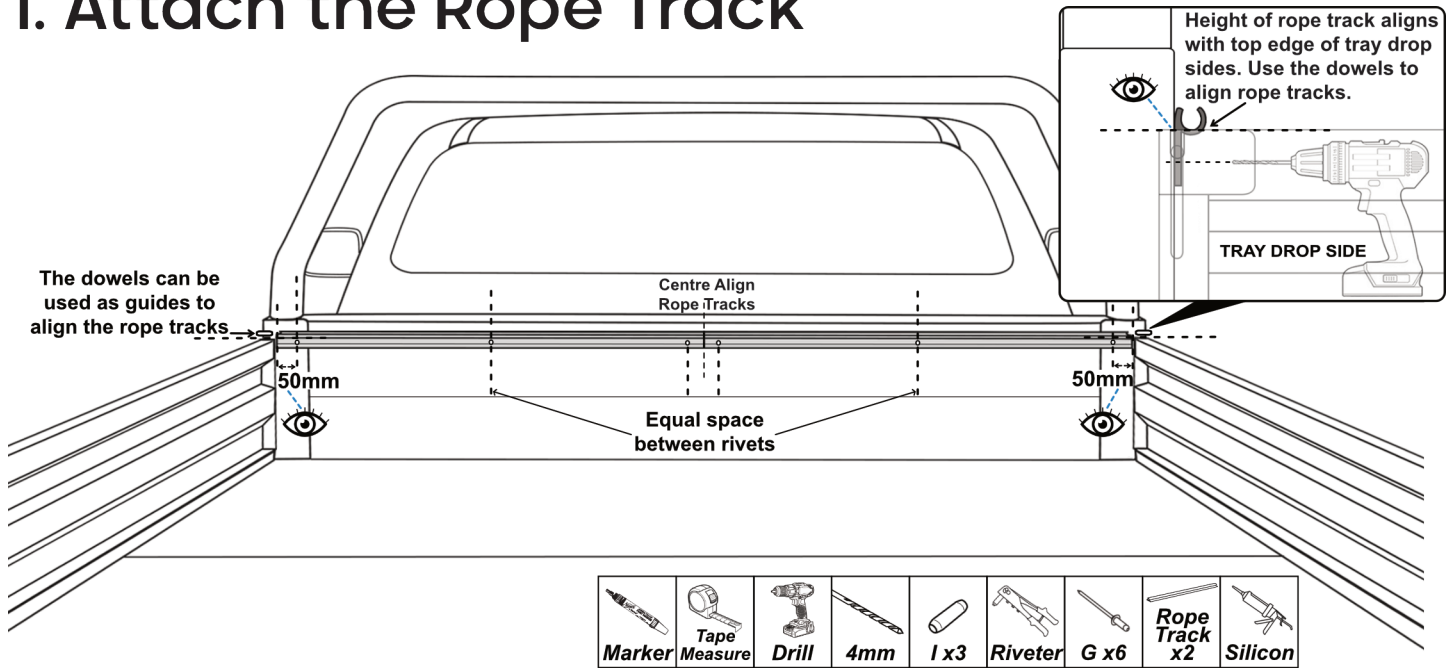

> To attach the rope tracks, measure and centre align rope tracks and place the tracks flush to the top edge of the tray's drop sides as shown above. Use the dowels to align the tracks together.

> Measure, mark and drill the two external holes 50mm from both ends of the rope track with a 4mm drill bit. Mark and drill 4 more holes with equal spacing between them.

## Foot bracket placement measurements overview

> Ensure the spacing shown below are maintained for the foot brackets. These spacing should be determined when all sides of the tray are in their closed positions.

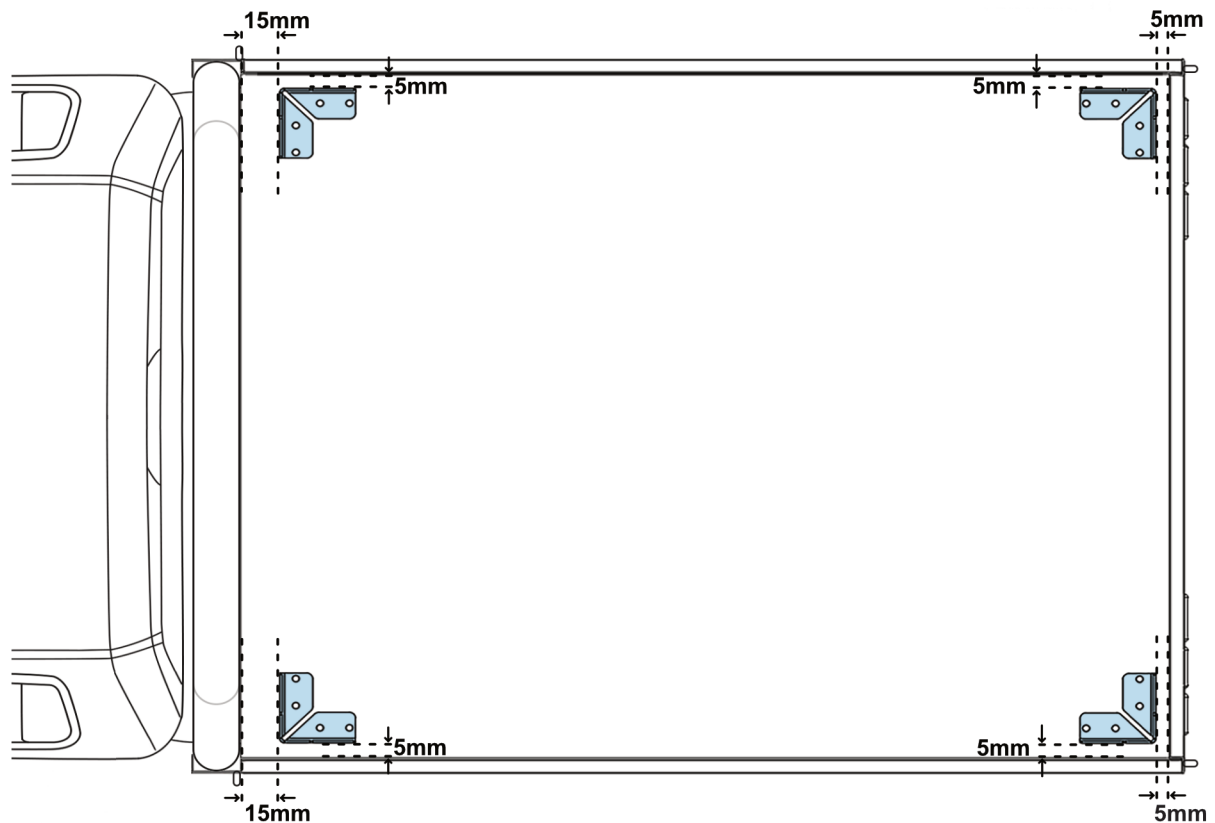

## 2. Attach rear foot brackets

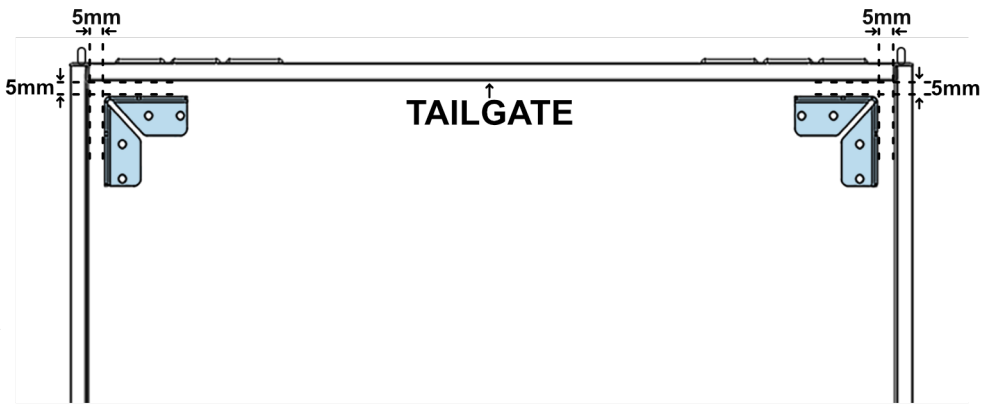
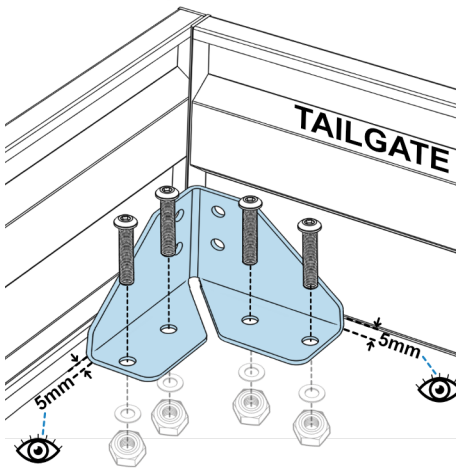

> Place and mark rear foot brackets **5mm** from both the tailgate and drop sides. Make sure the spacing is determined when the tray is completely closed.

> Mark the 4 floor holes on the foot brackets for both the rear foot brackets and drill the holes with a 8mm drill bit. **Take caution to check and make sure there are no obstructions underneath the tray as the drill bit goes through. Repeat for the other rear corner.**

> Attach the two rear floor brackets to floor of the tray using 8x M8 screws. 8x M8 washer and M8 nyloc nuts secure the screws in place from underneath the tray floor.

## 3. Attach front foot brackets

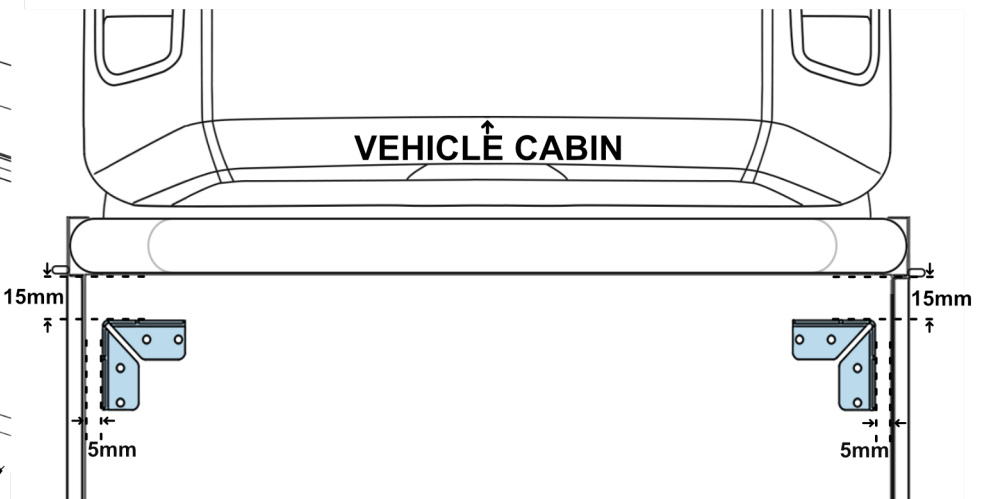
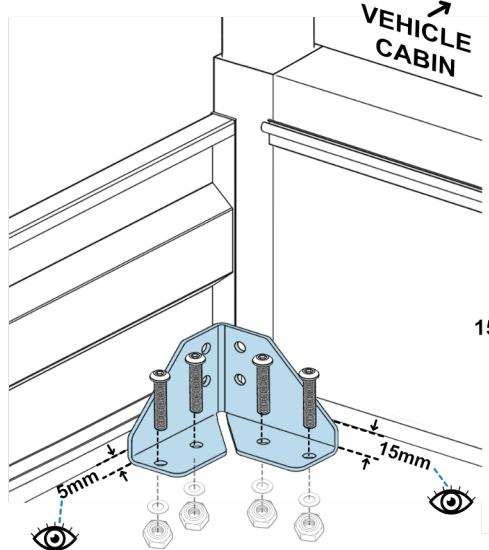

> Place and mark front foot brackets **15mm** from front end of tray and **5mm** from drop sides. Make sure the spacing is determined when the tray is completely closed.

> Mark the 4 floor holes on the tray for both the front foot brackets and drill the holes with a 8mm drill bit. **Take caution to check and make sure there are no obstructions underneath the tray as the drill bit goes through. Repeat for the other front corner.**

> Attach the two front floor brackets to floor of the tray using 8x M8 screws. 8x M8 washer and M8 nyloc nuts secure the screws in place from underneath the tray floor.

## 4. Build top corner brackets with legs

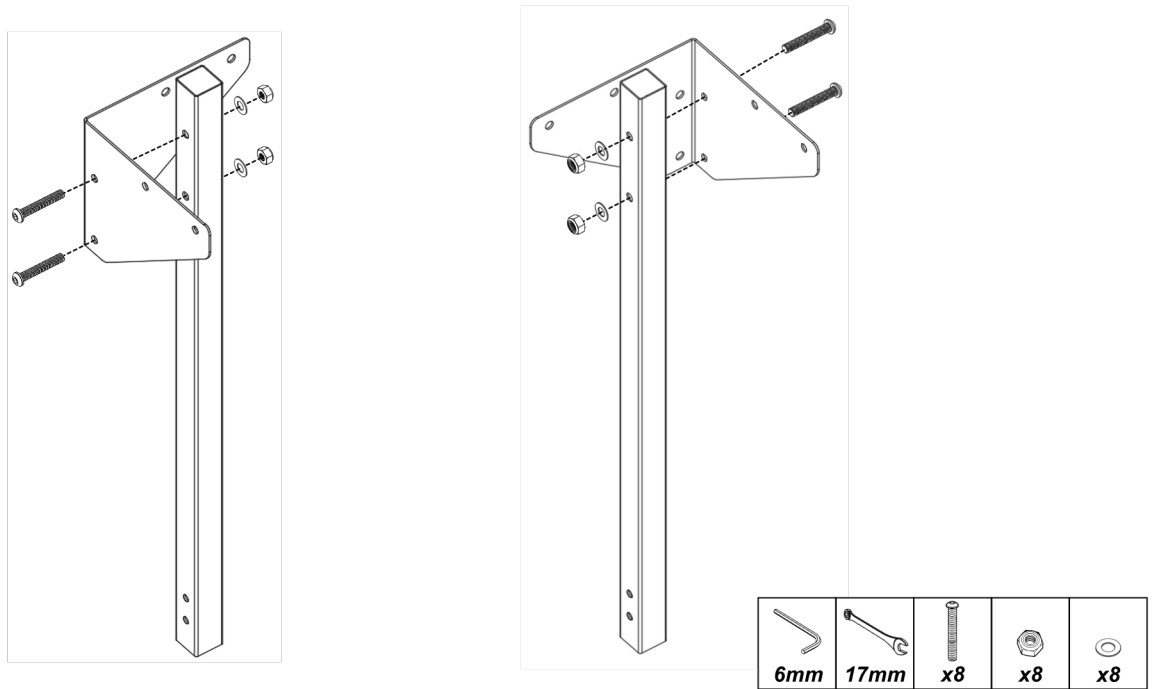

> The top corner brackets attach to the legs with 10mm screws, 10mm washers and 10mm nyloc nuts. Pay attention to screw hole orientations. Repeat for the second set.

## 5. Build both the end frames

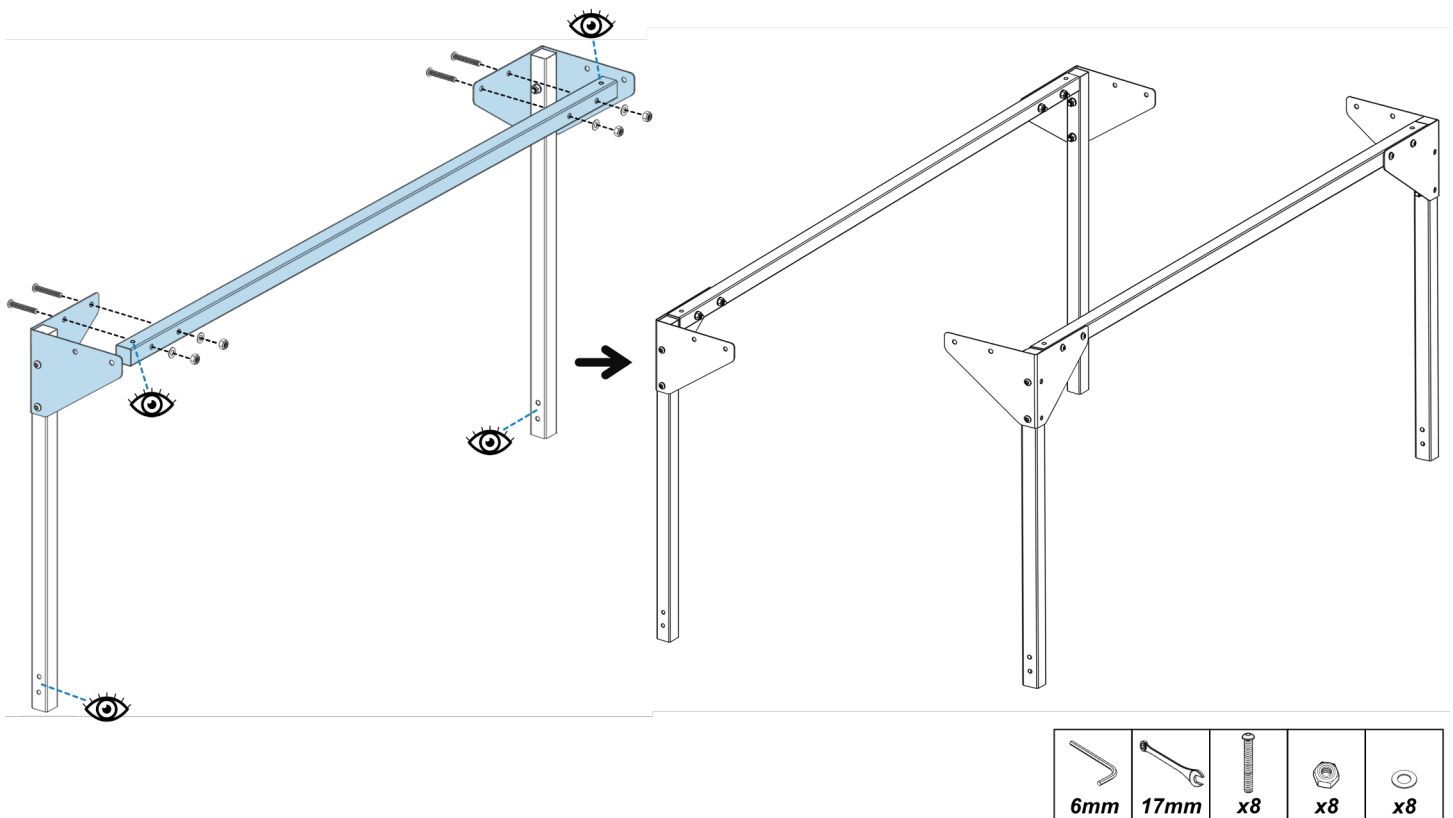

> The corner brackets attach to the end frame bar with 10mm screws, 10mm washers and 10mm nyloc nuts. Repeat for the second end frame.

## 6. Attach end frames to foot brackets

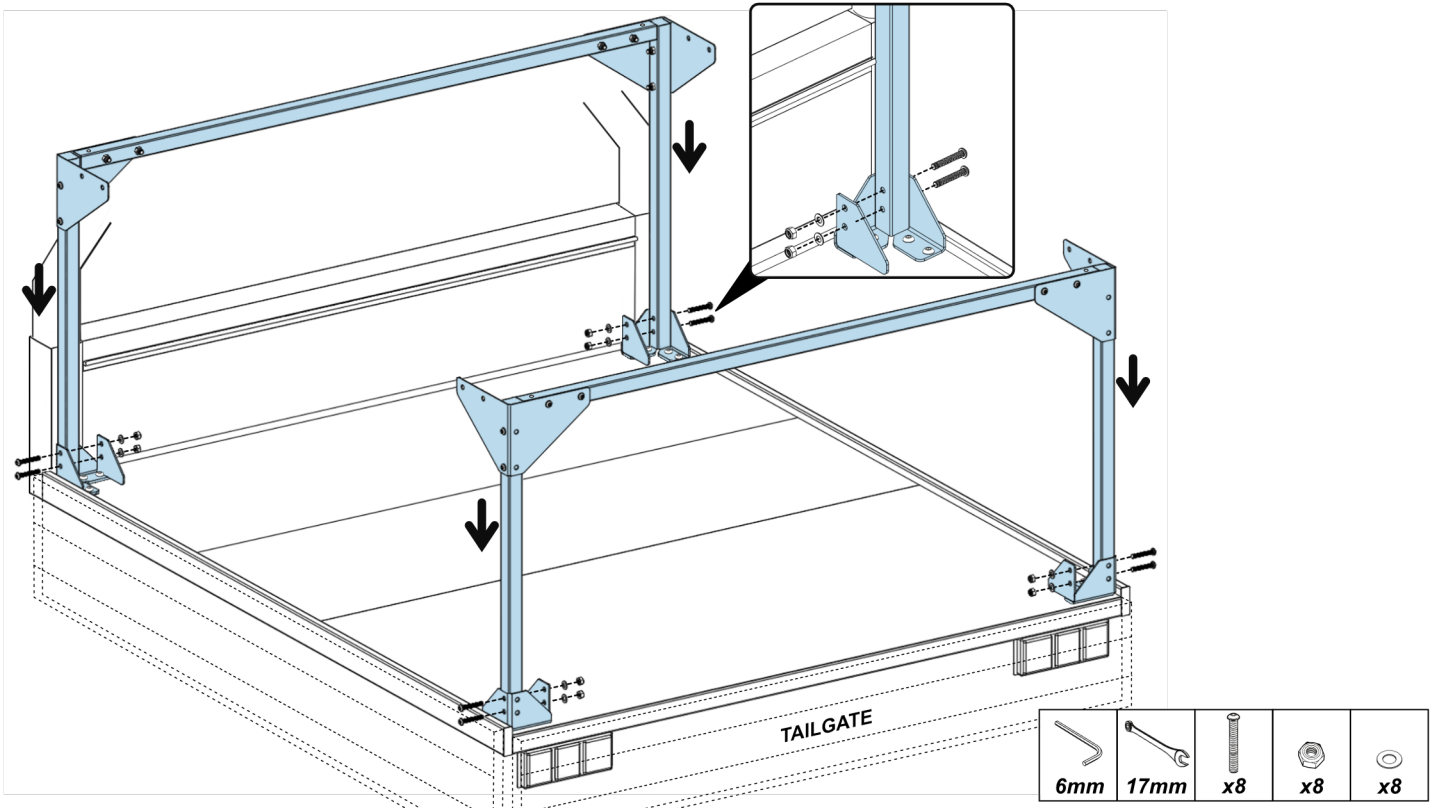

> Place the legs of the end frames into the foot brackets. 10mm screws, 10mm washers and 10mm nyloc nuts attach the end frame's legs to the foot brackets, along with the support plates. Repeat for both end frames.

## 7. Attach side bars to corner brackets

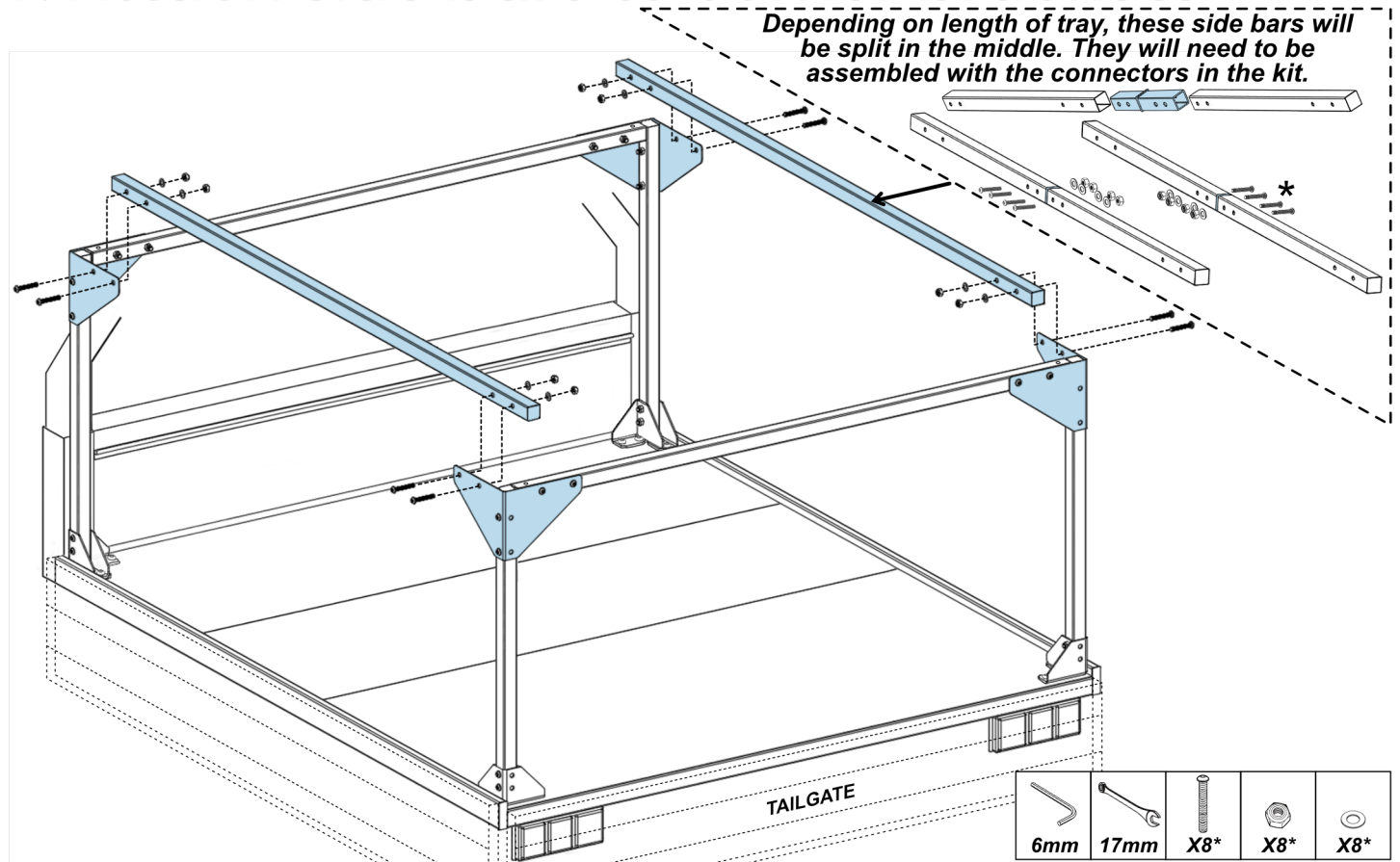

> 10mm screws, 10mm washers and 10mm nyloc nuts attach the side bars to the end frame's corner brackets. Repeat for both sides.

## 8. Drill the top support bar ends

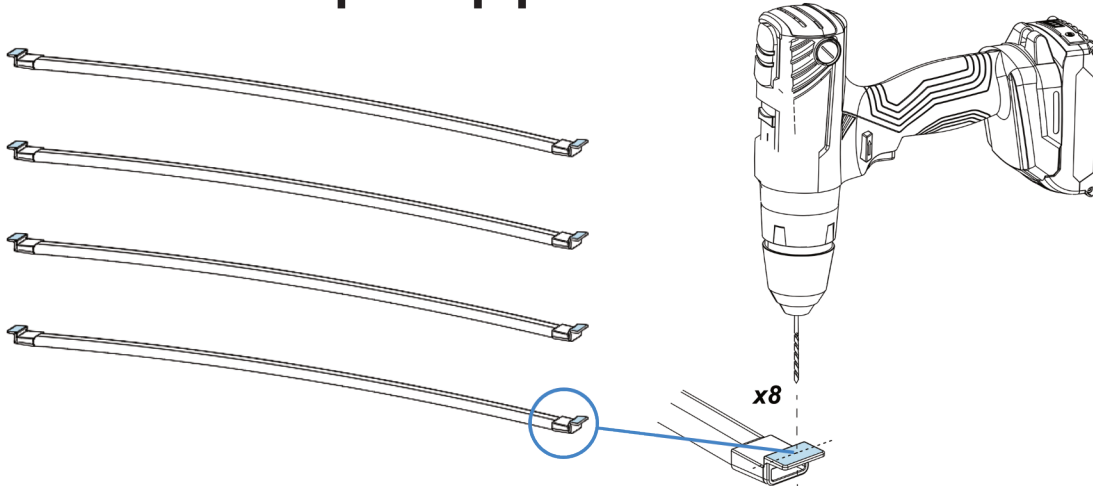

> Drill 4mm holes centred on the plastic ends of the support bars

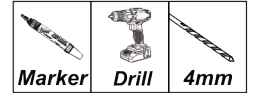

## 9. Attach support bars to top of frame

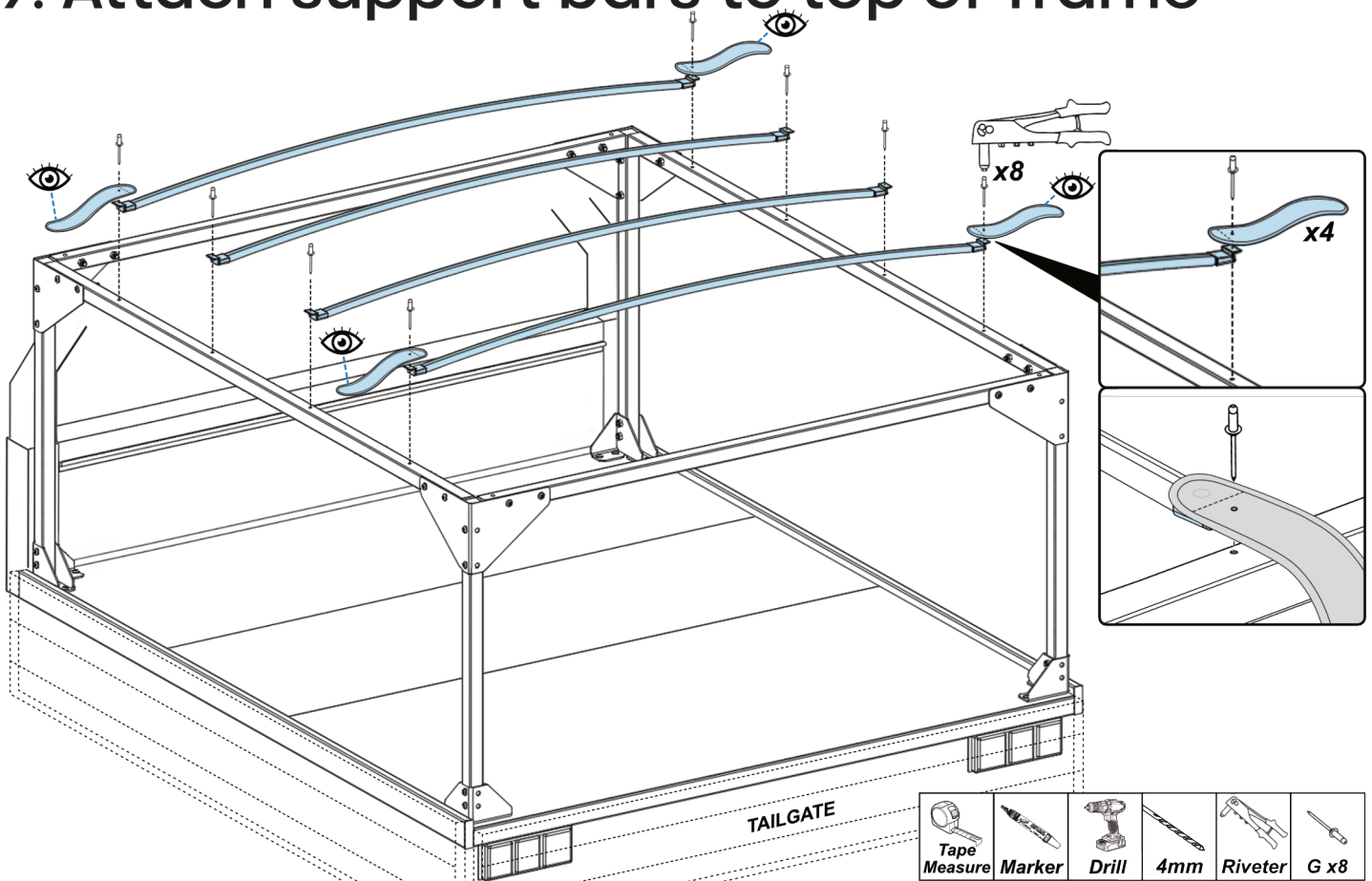

> The four ends of the support bars sit 300mm from ends of the canopy frame. The rest of the support bars are measured and placed at equal spacing from one another. Mark, drill and rivet the support bars on frame as shown. Use 4mm drill bit to drill holes in frame. **The four corners are riveted with the magnetic loops.**

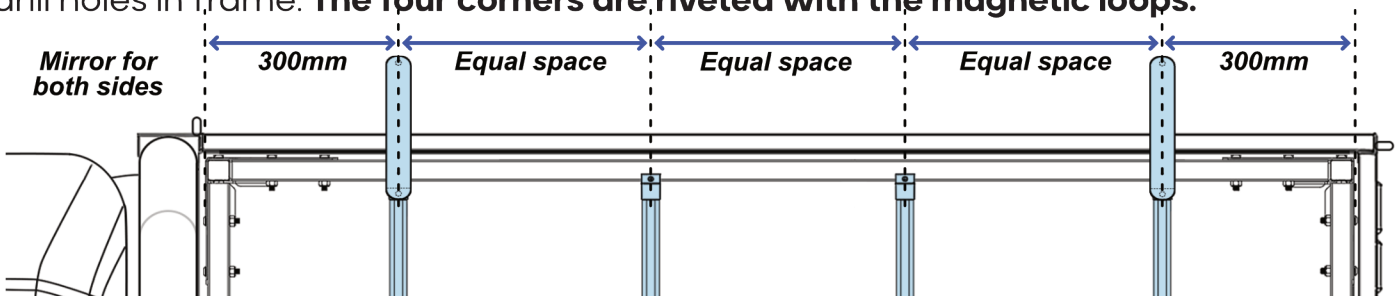

TOP VIEW

6 of 9

## 10. Place canopy cover over the frame

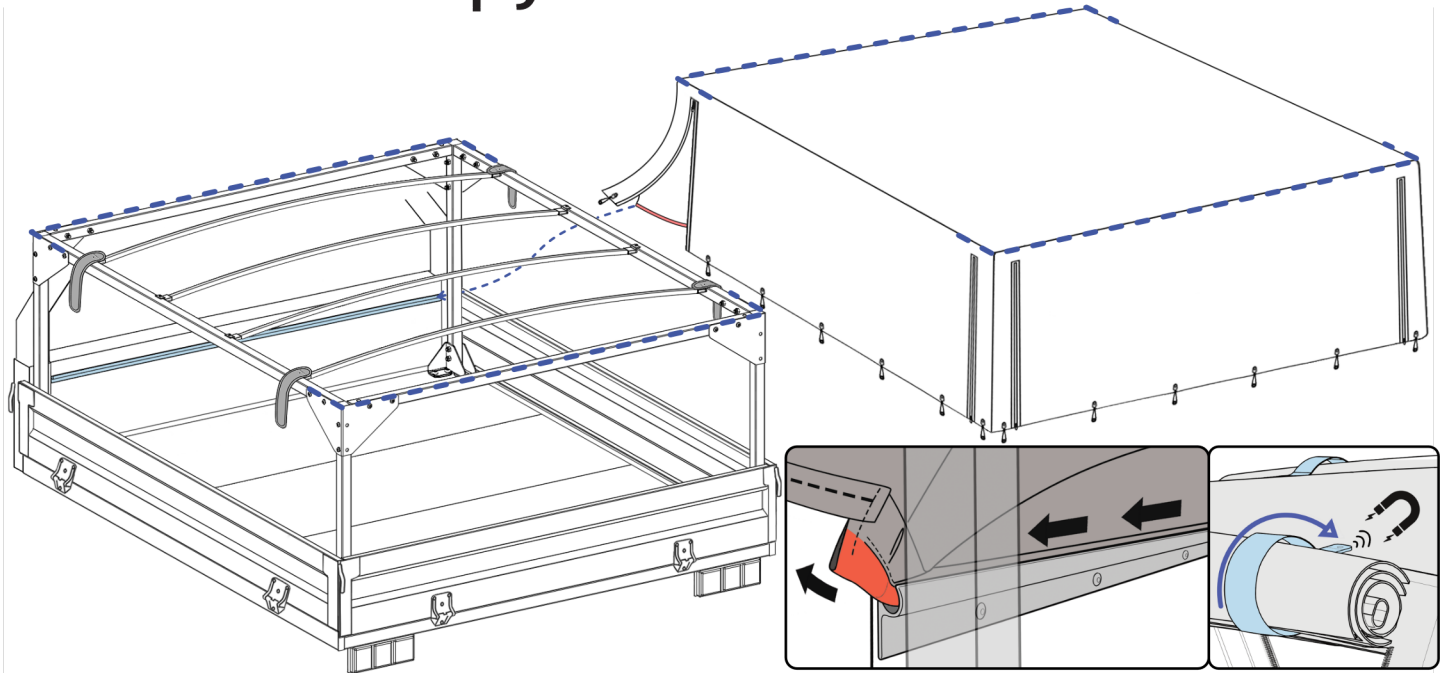

> Close the drop sides and tailgate. Then slide the front rope end of the canopy cover through the rope track from one side of the tray and adjust the rest of the cover over the frame, aligning all the edges of the cover to that of the frame.

## 11. Mark and drill bunji cord button locations

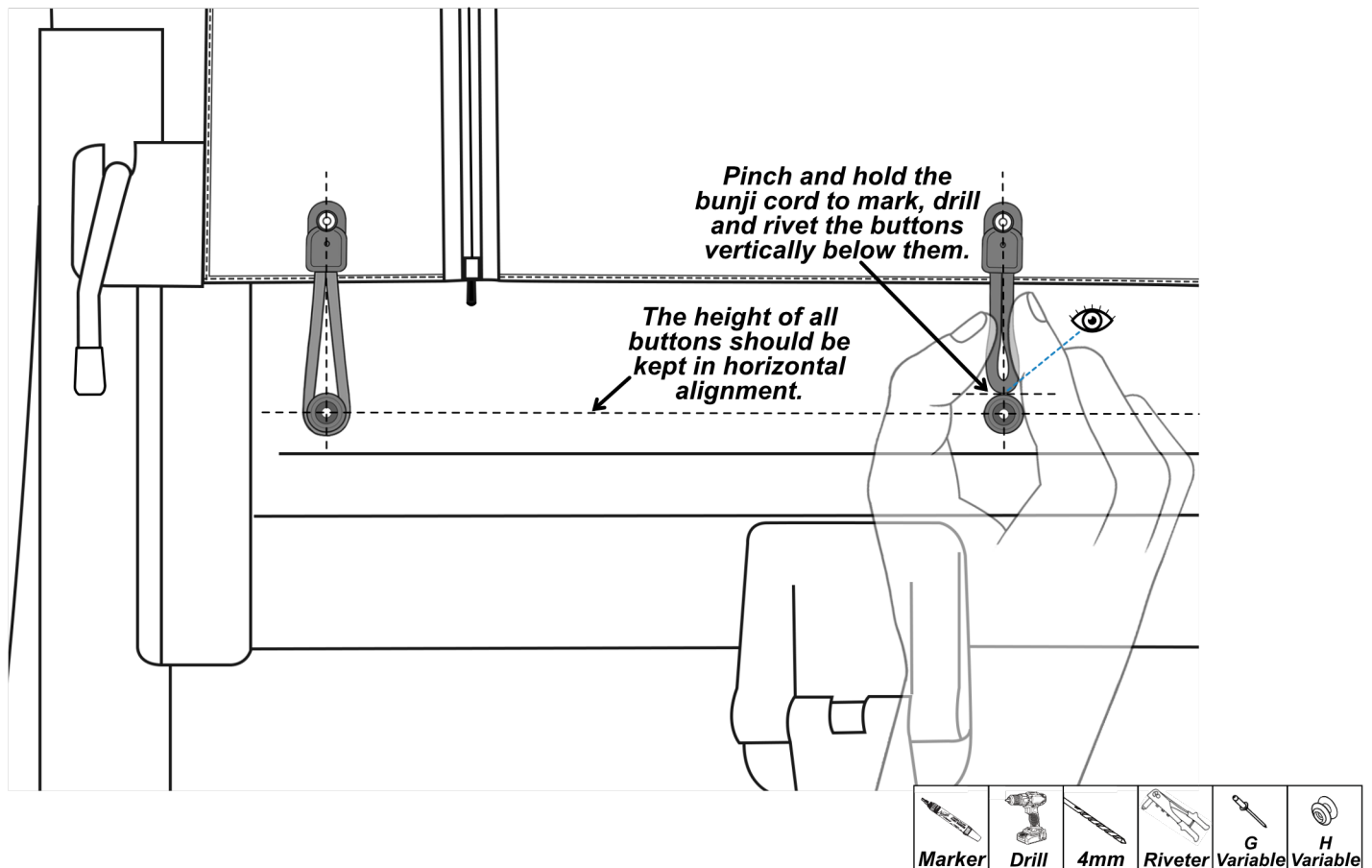

> Pinch bunji cord with fingers with some tension. Vertically line up each button to each bunji cord, starting from the rear bunji cord, alternating from side to side while working towards the front of the vehicle. Attach each bunji cord to their respective buttons as they are fitted.

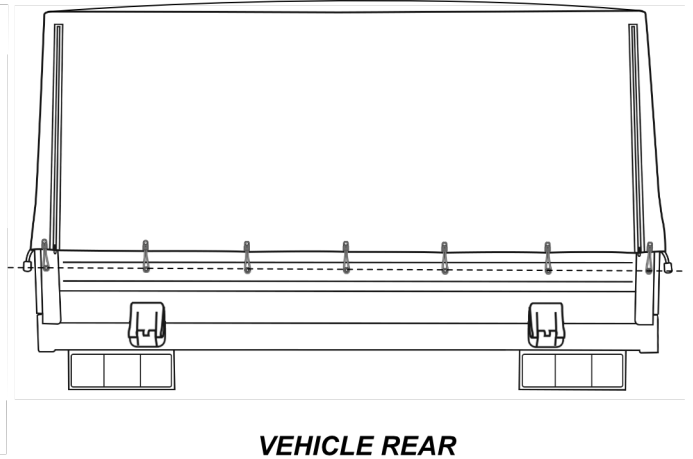
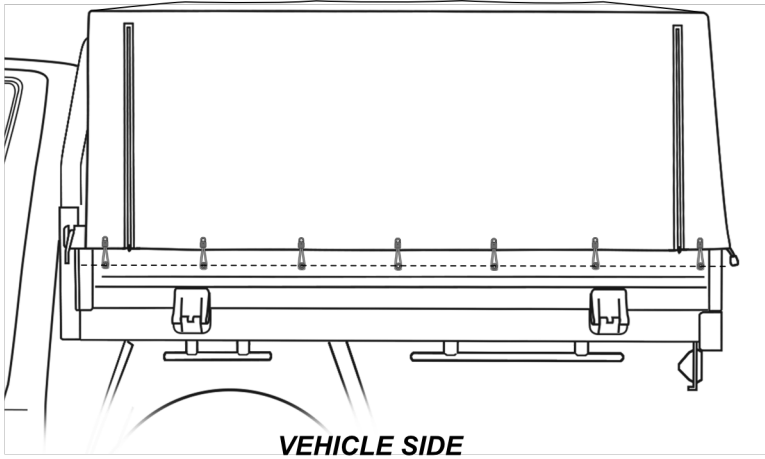

> Mark and drill all the rivet locations as per step 11. When all the buttons are riveted and bunji cords are attached to their respective buttons, it should look like above.

## LADDER RACK OPTION -

> For ladder rack option, follow the installation method below -

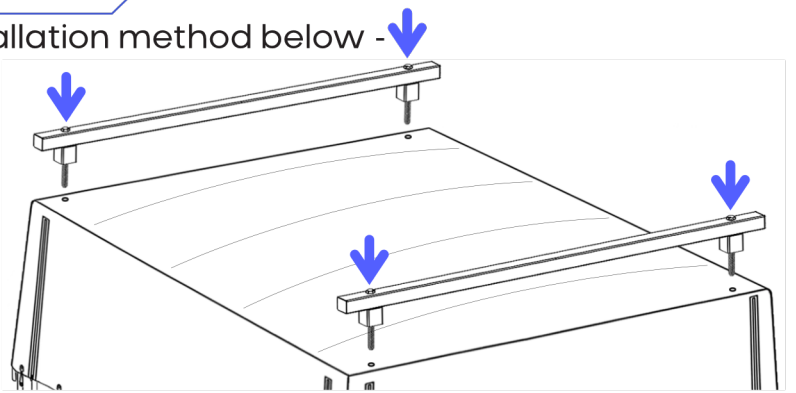
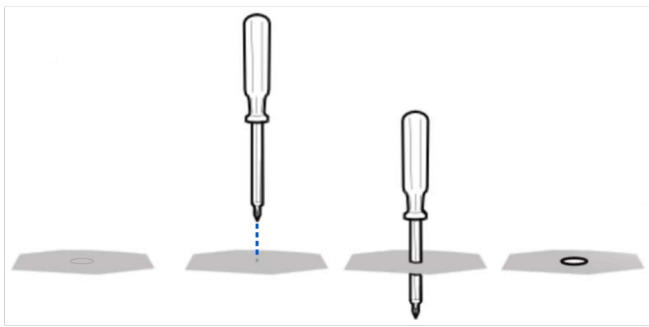

> Locate the holes on the corners of the top frame and carefully punch holes through them with a phillips head screw driver. Install ladder racks using the order below.

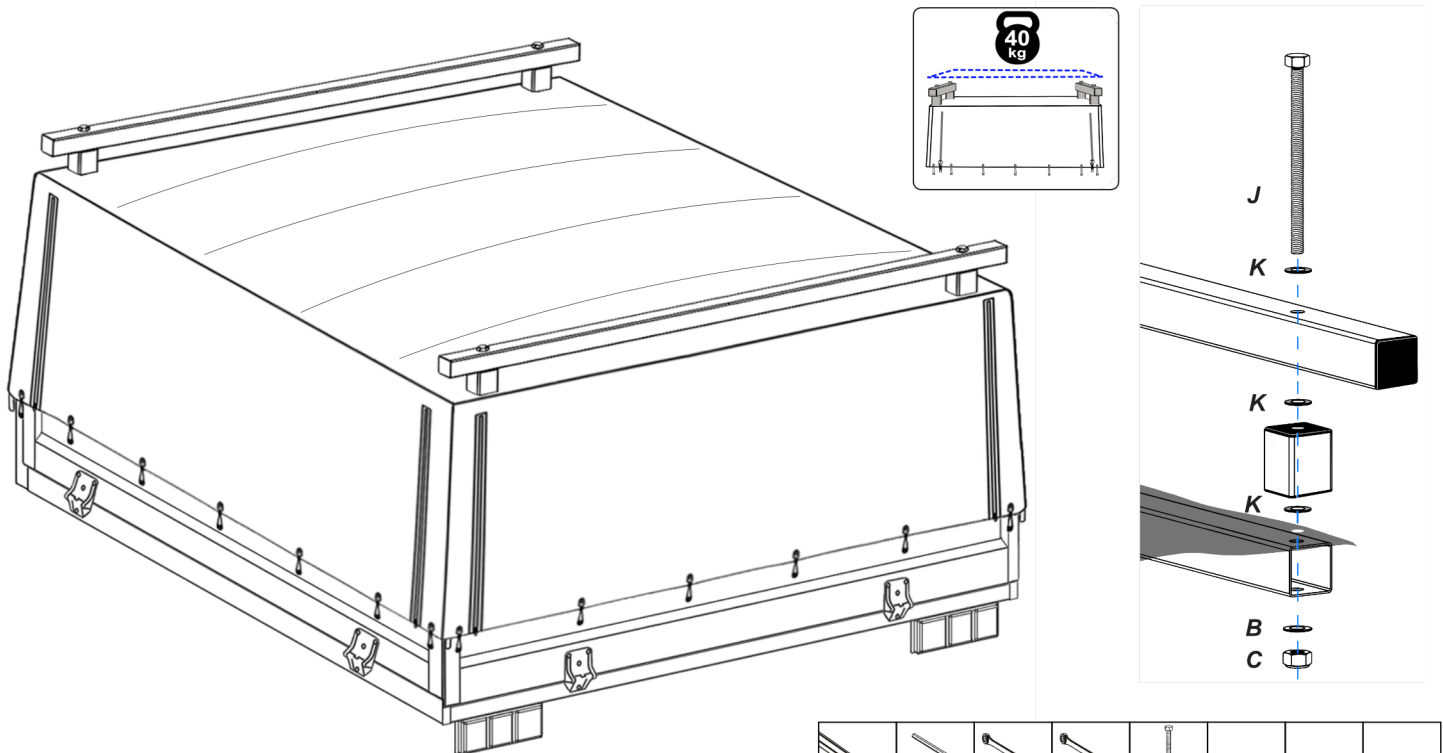

Phillips Driver	6mm	17mm	17mm	J x4	B x4	C x4	K x12

**Congratulations! Your installation is now complete!**



***Send Us A Photo of your Wildback!***

Happy with how your canopy turned out?  
Please send us a photo to: [sales@aussietonneaus.com.au](mailto:sales@aussietonneaus.com.au)



## **INSTRUCTIONS FOR USE**

### **Safety**

- Ensure the canopy is completely closed before driving.
- Regularly check the tightness of the fasteners of the frame.
- Load must be evenly distributed and adequately secured.
- Do NOT exceed 40kg load on Ladder Racks (if canopy is fitted with ladder racks).

### **Load carrying Requirements and recommendations**

- The load must be evenly distributed over the area of the Ladder Rack system, and the center of gravity of the load kept as low as possible. Loads which overhang the ends of the carrier system must conform to any relevant laws or by-laws in your area, and shall be adequately secured.
- Loads must be adequately secured using suitable straps or similar tightening and locking devices. The security of the load and roof load carrier shall be checked after loading and regularly throughout the journey. Elastic straps must not be used. The user is warned to maintain and to use straps in working order.
- It is recommended that items which may produce significant lifting forces (surfboard, sailboard, etc) are not carried side-by-side, but in such a way that lifting force is minimized, securing them independently to the front and rear of the vehicle using straps or other methods which are capable of withstanding the lifting forces. Elastic straps must not be used. Where specialized accessories are available to carry or secure loads, it is recommended that they are used.
- The handling characteristics of a vehicle (in particular crosswind sensitivity, handling on bends and braking) change when a carrier system is fitted and especially if that system is loaded. Driving techniques should be altered to allow for these changes, speed reduced, especially on bends, and braking distances made greater.