

AUSSIE TONNEAUS WILDBACK CANOPY

FITTING INSTRUCTIONS

Part Name/Description:

Part No: ATW01567	Holden Rodeo RA DC, 2003 to 2008, No LR Wildback Canopy
Part No: ATW01568	Holden Rodeo RA DC, 2003 to 2008, LR Wildback Canopy
Part No: ATW01579	Holden Colorado RC DC, 2008 to 2012, No LR Wildback Canopy
Part No: ATW01580	Holden Colorado RC DC, 2008 to 2012, LR Wildback Canopy
Part No: ATW01581	Isuzu D-Max RA DC, 2003 to 2012, No LR Wildback Canopy
Part No: ATW01582	Isuzu D-Max RA DC, 2003 to 2012, LR Wildback Canopy
Part No: ATW01735	GWM V200, V240 DC, 2010 to 2014, No LR Wildback Canopy
Part No: ATW01736	GWM V200, V240 DC, 2010 to 2014, LR Wildback Canopy

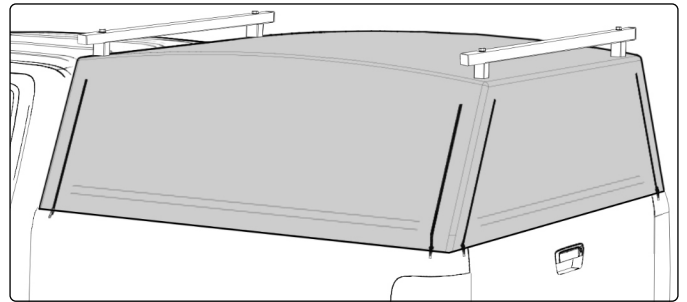
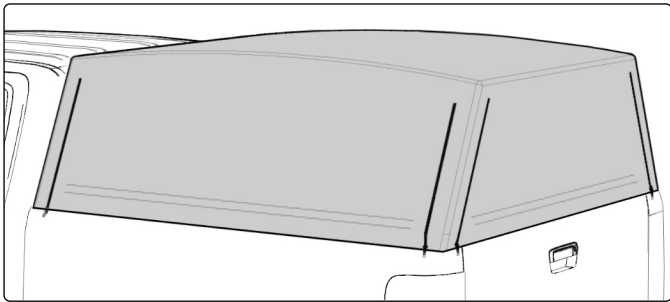

In the Box

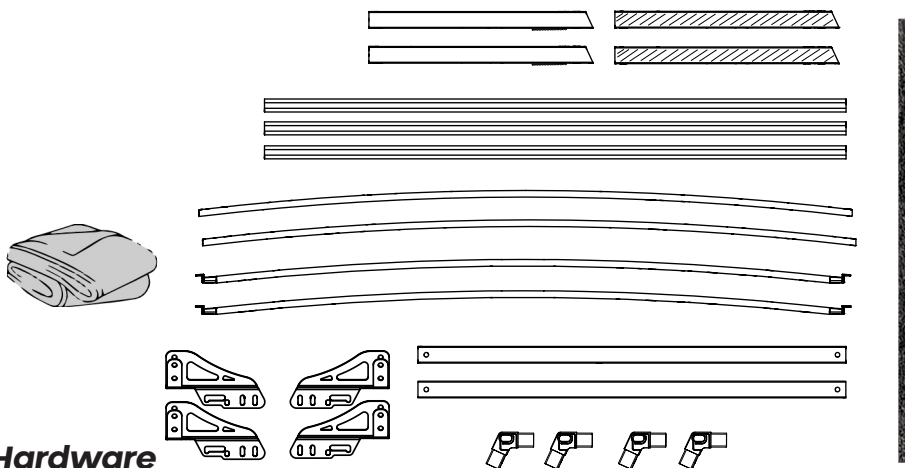

Hardware

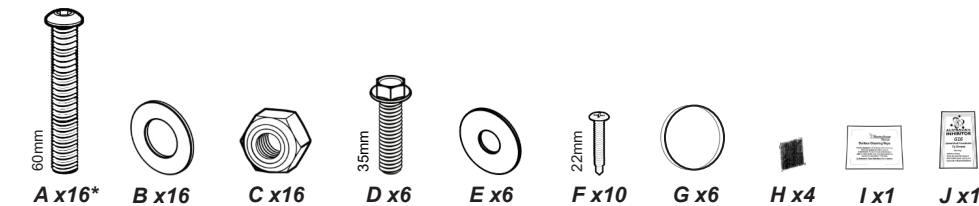

*A x12 for LR version

Tools Required

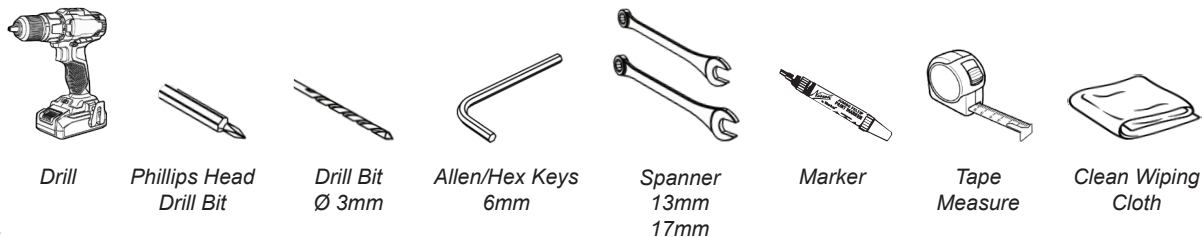

Glossary

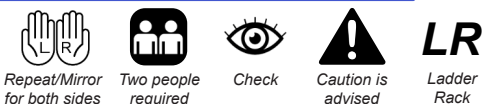

Safety Notes

- Wear appropriate Personal Protective Equipment.
- During the accessory fitment, ensure all Australian automotive safety practices are followed.
- Always refer to the vehicles workshop manual when removing components.



LADDER RACK OPTION

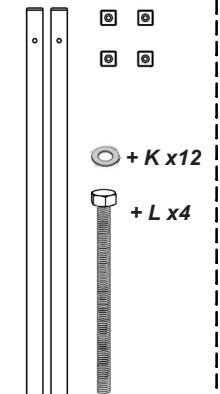

Additional Tools Required

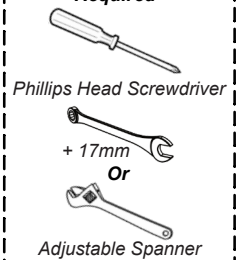

Any vehicle accessories which are not properly fitted, can be dangerous. Please read these instructions carefully prior to fitting and comply with the instructions at all times. If in any doubt please contact us e: sales@aussietonneaus.com.au

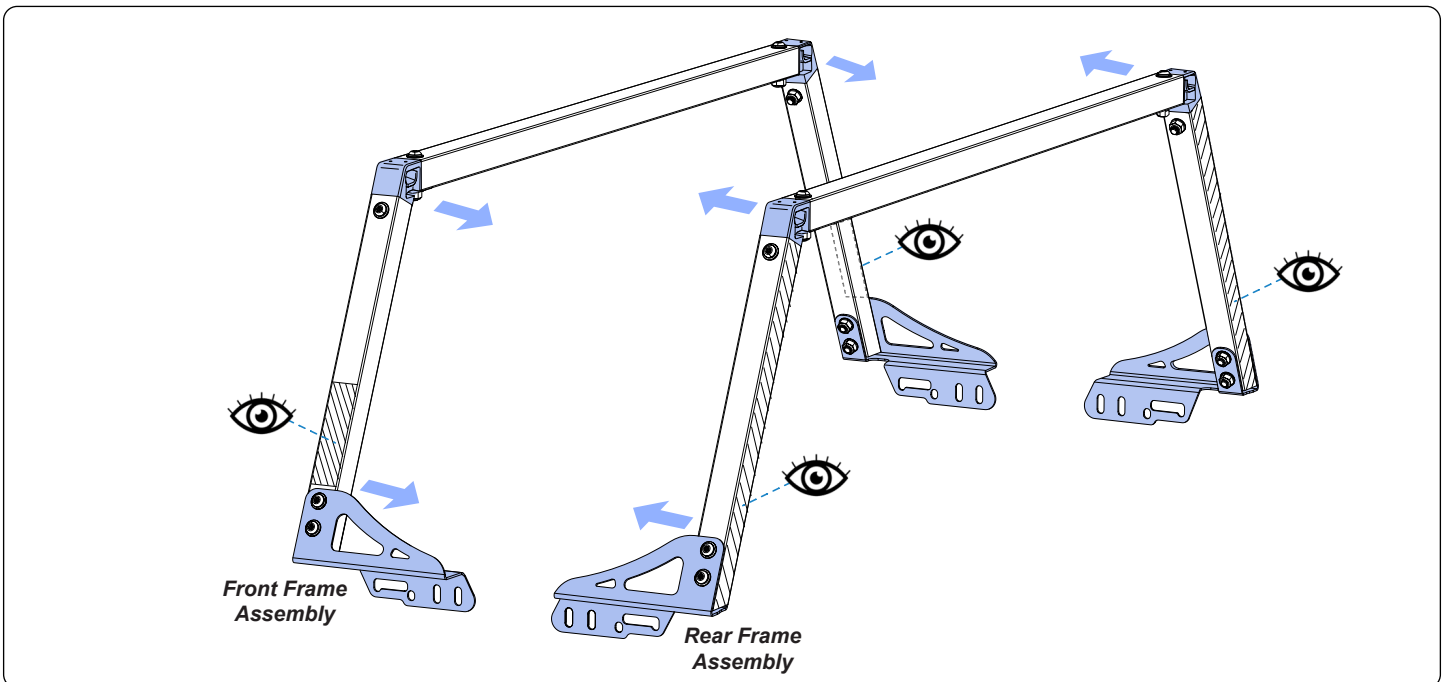
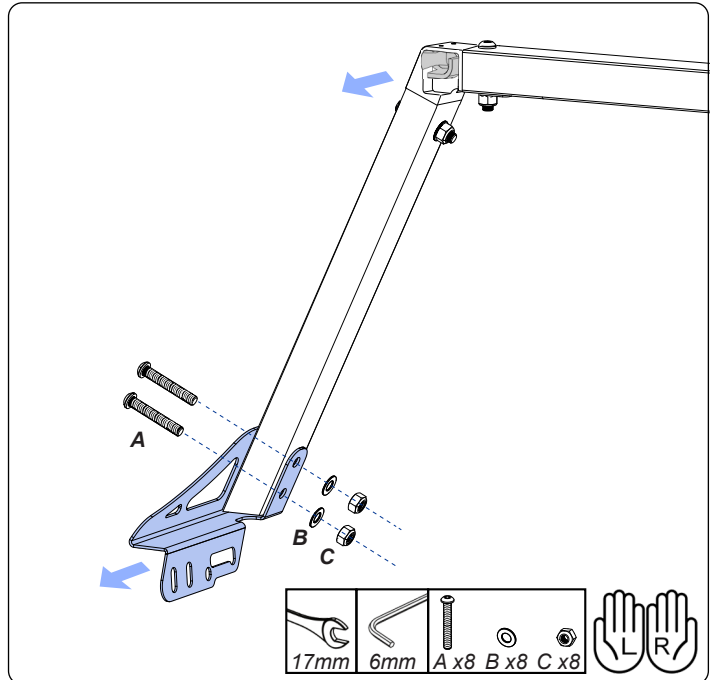
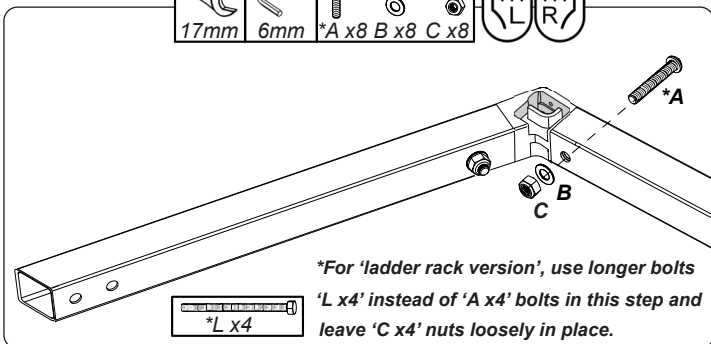
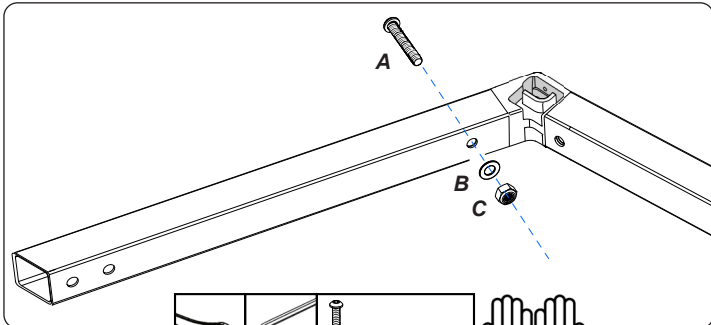
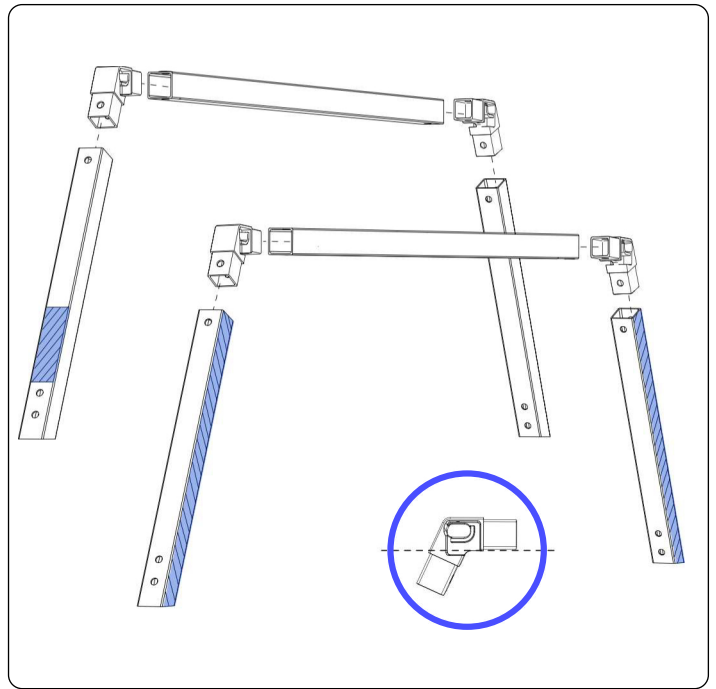
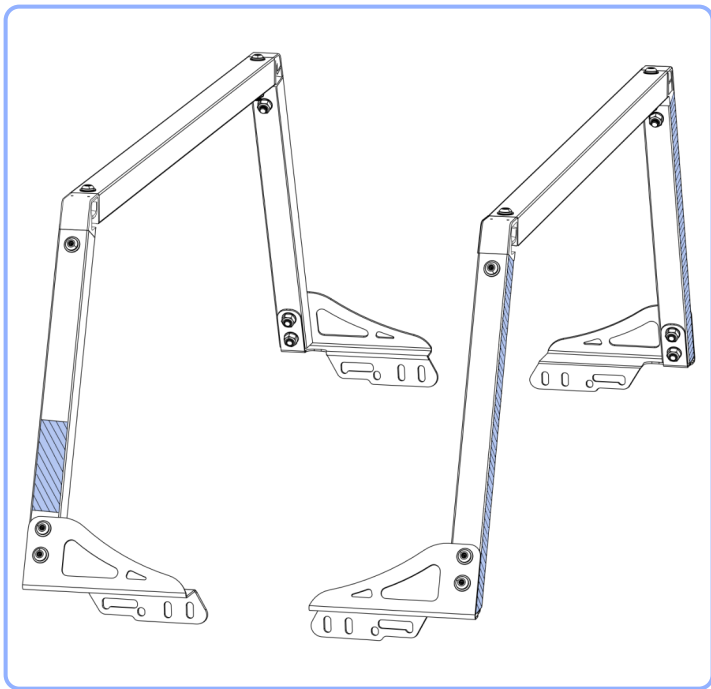

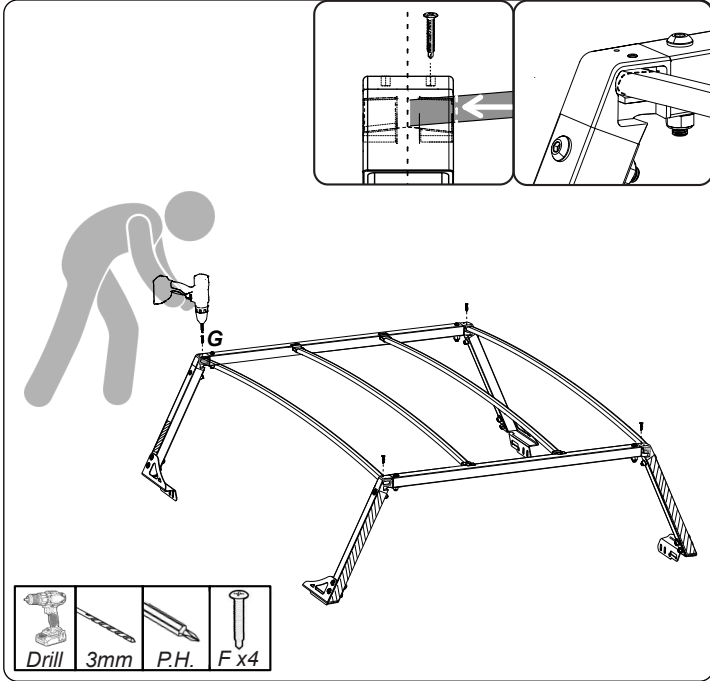
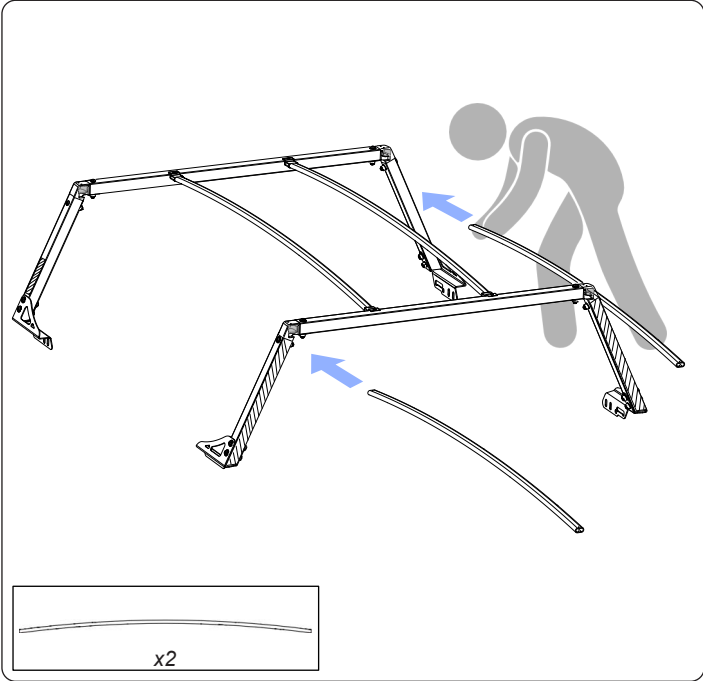
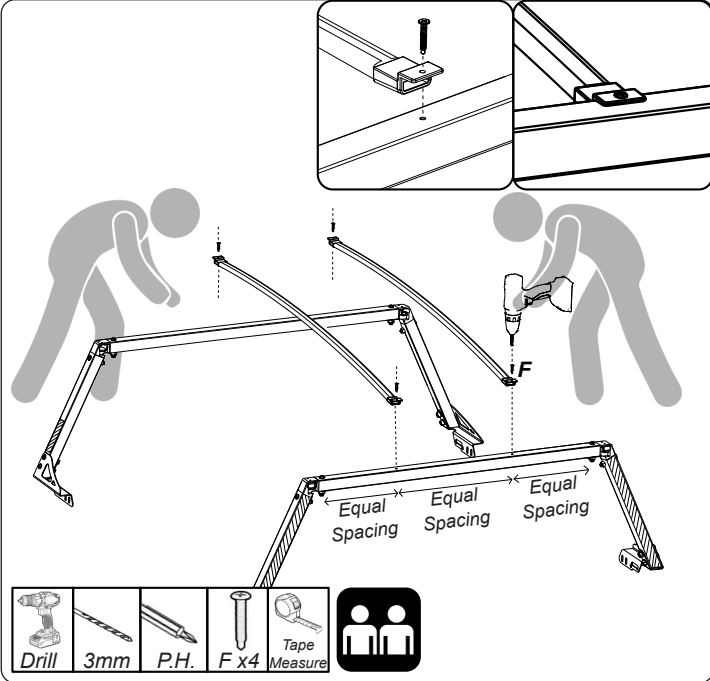
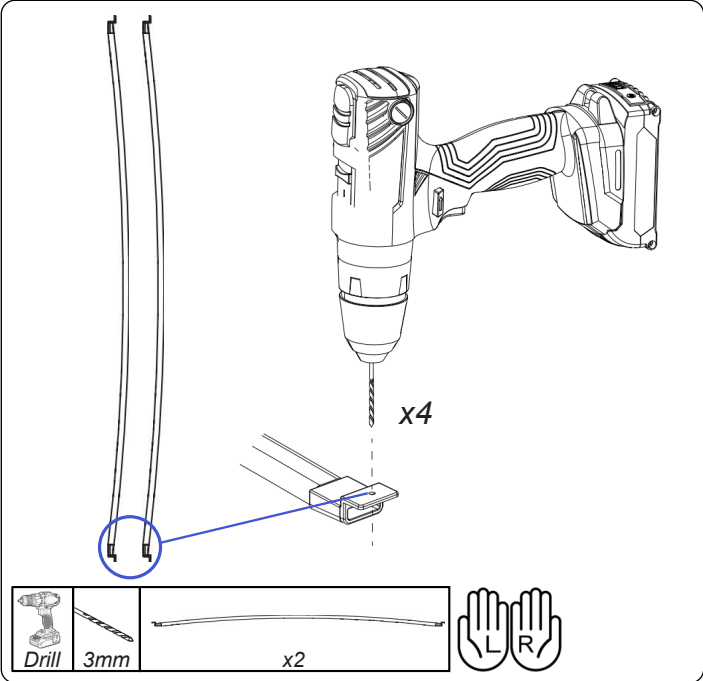
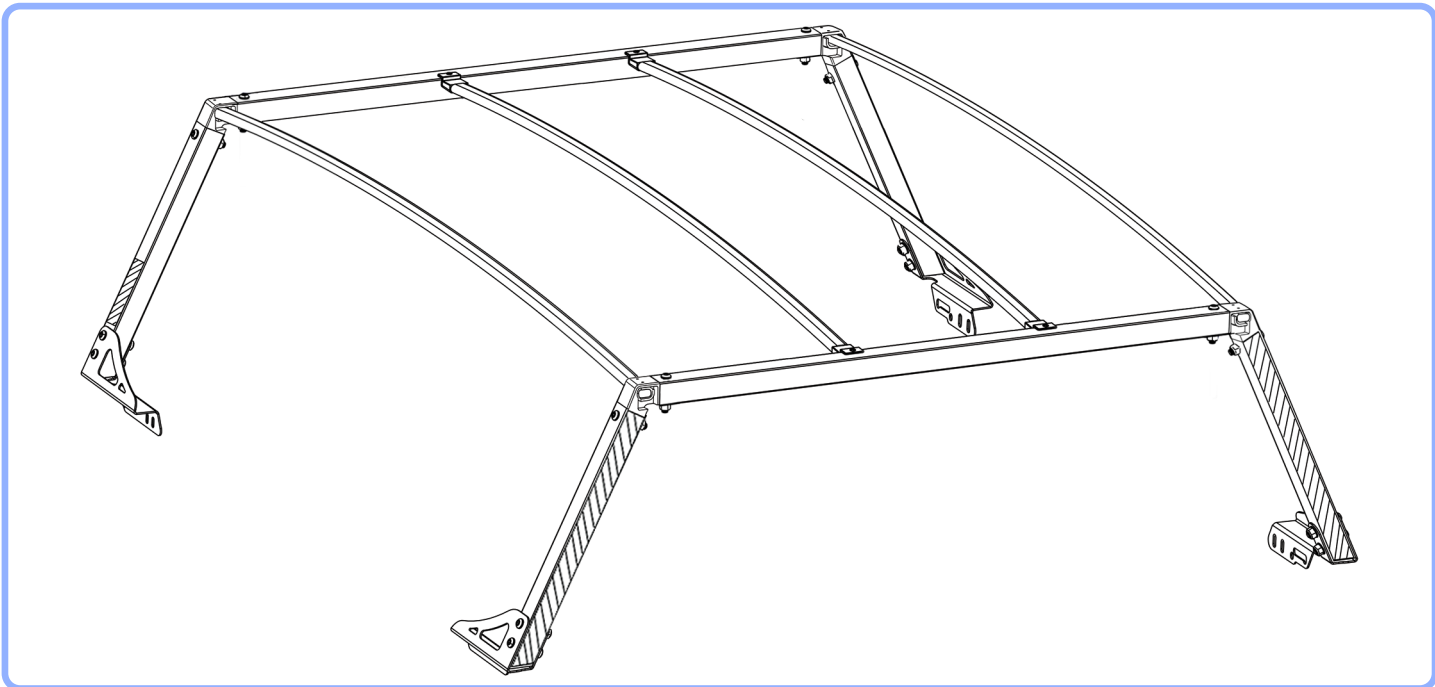

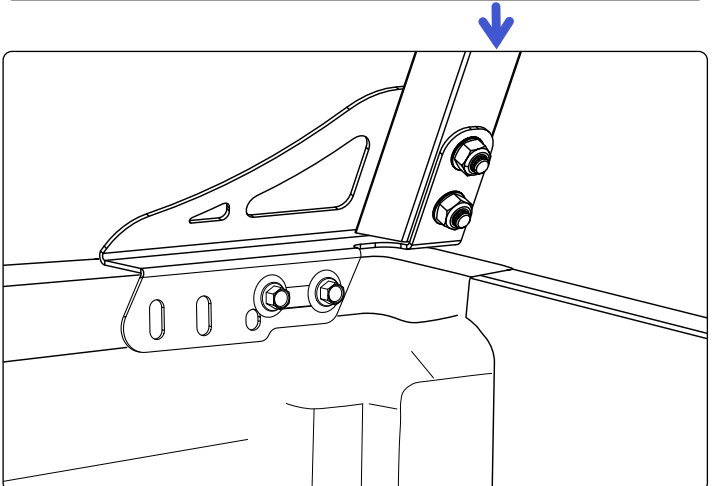
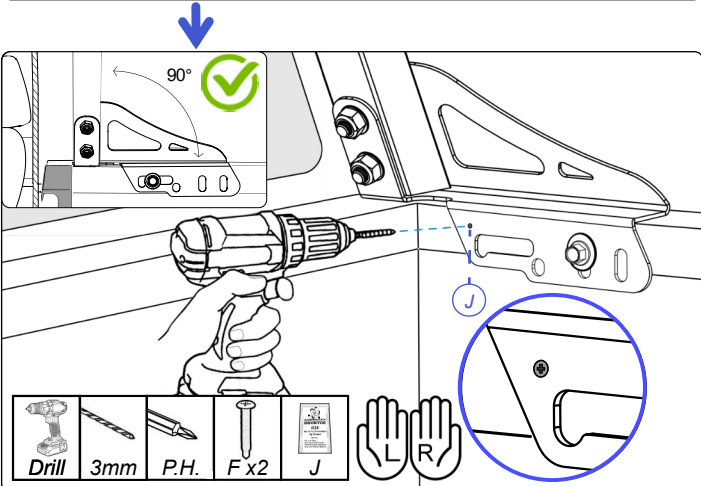
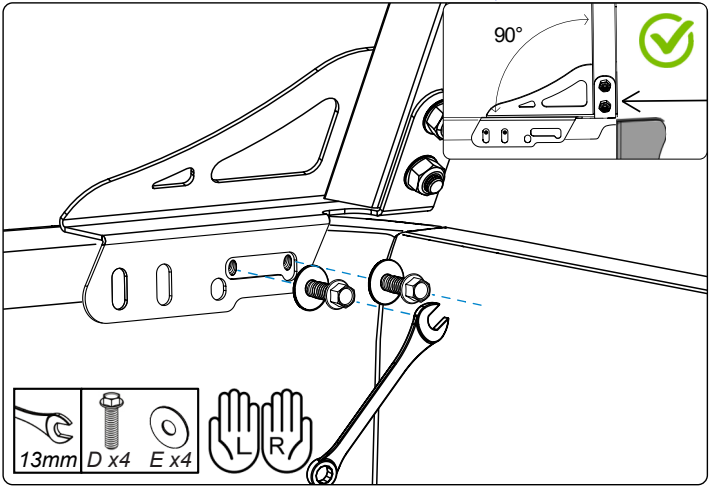
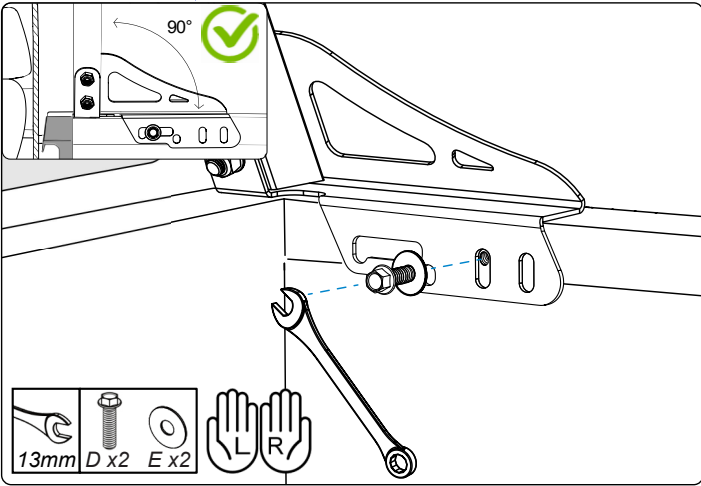
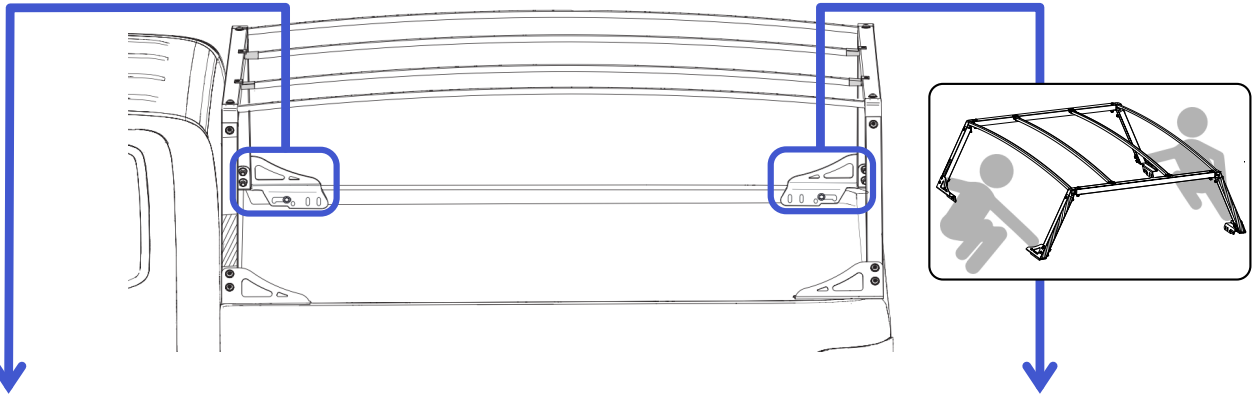
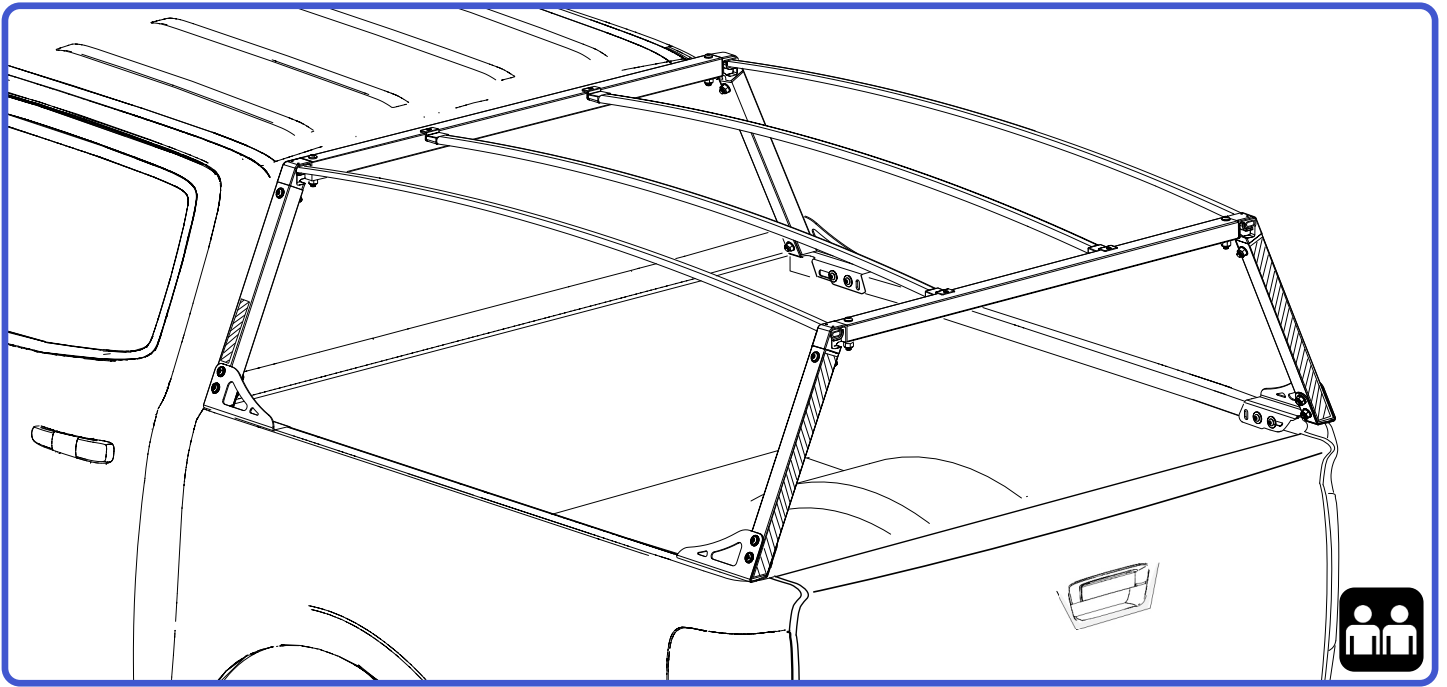

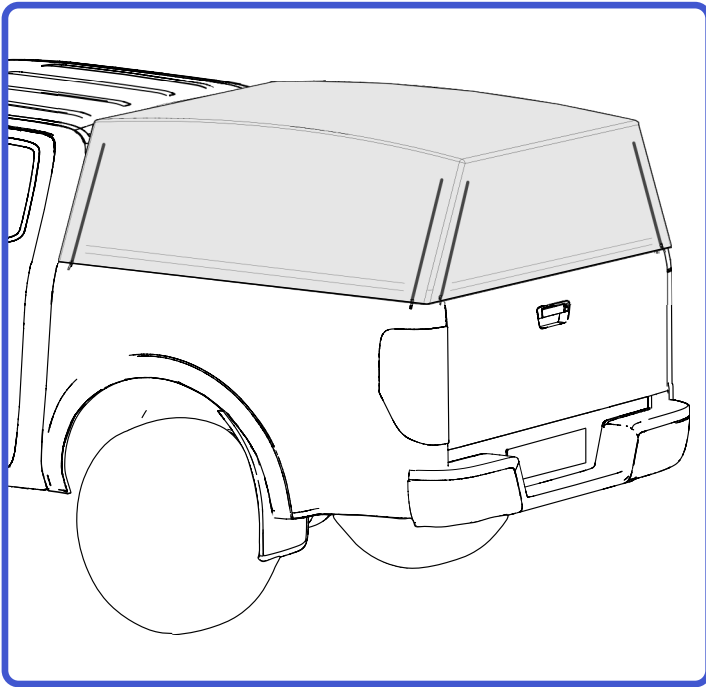

Refer to **page 6** on how to install ladder rack option.
 Refer to **page 7** on how to attach the front of canopy cover to front edge of tub. **For non ladder rack version skip page 6.**

Ensure the covers roof seam lines match the frame's top edges.
 Avoid overhang. Adjust the cover as needed and secure it with the hook-and-loop velcro strips on the frame legs.

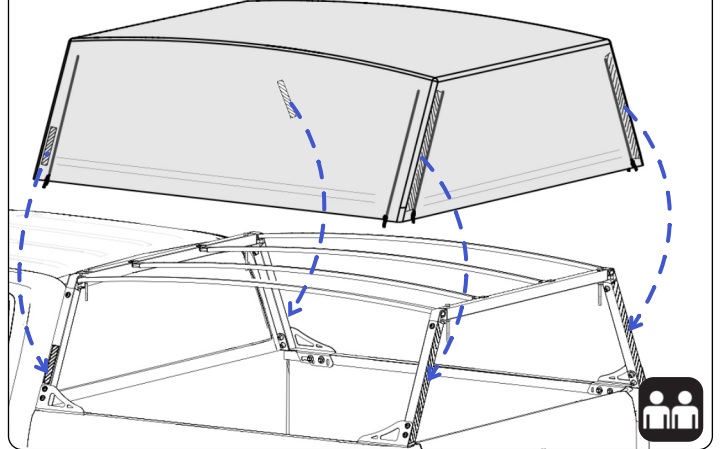

Canopy tethering system. Repeat for opposite front corner.

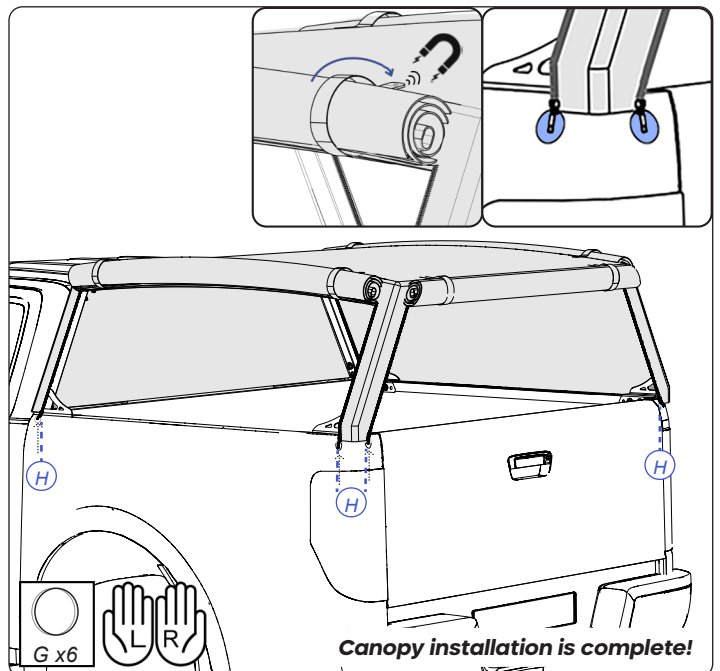
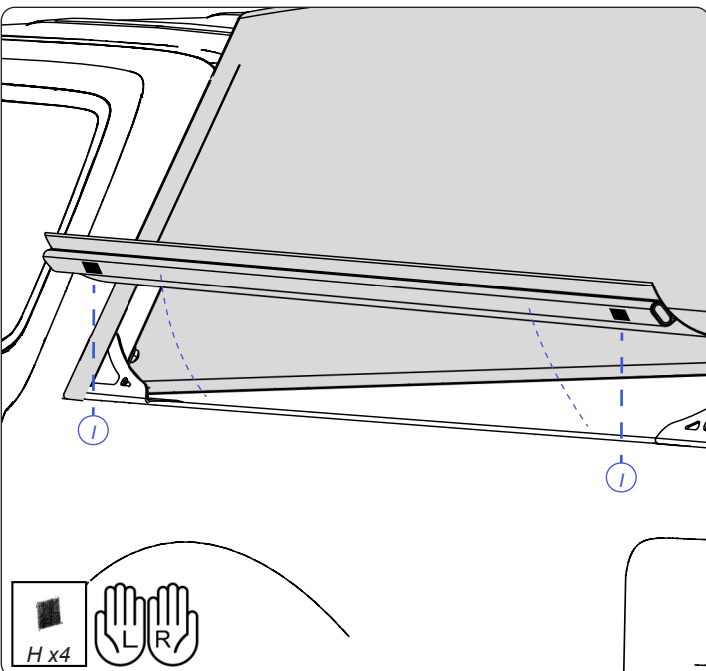
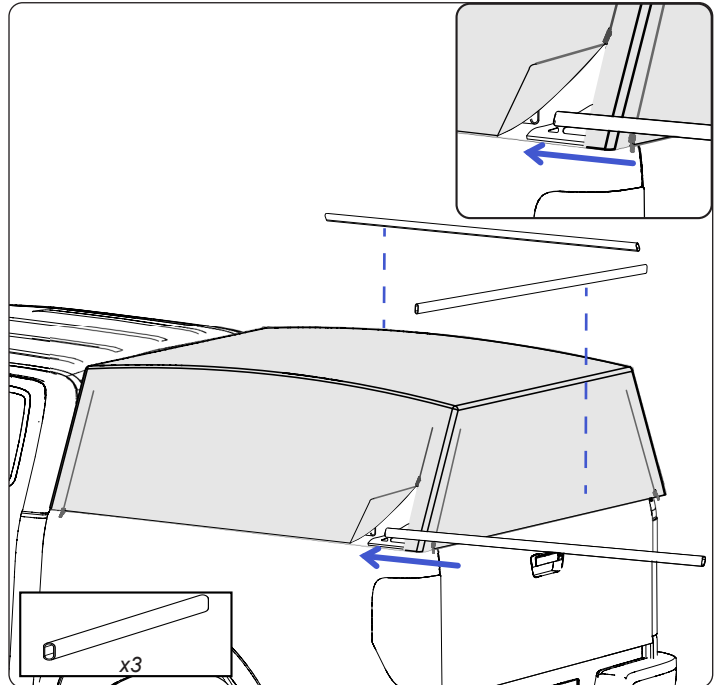
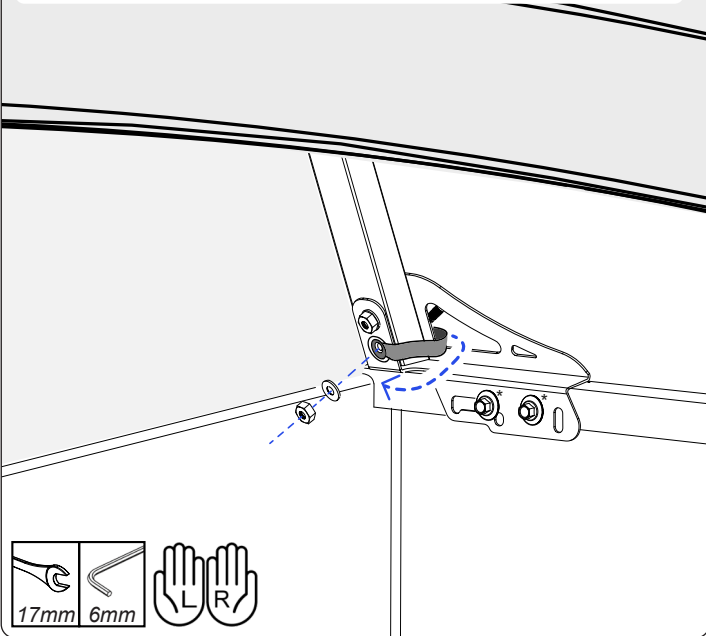

Canopy installation is complete!

HOW TO ATTACH LADDER RACKS FOR LADDER RACK OPTION -

If installing the ladder rack version, the bolts and nuts shown will need to be removed before placing the canopy cover on its frame. Follow steps as shown below -

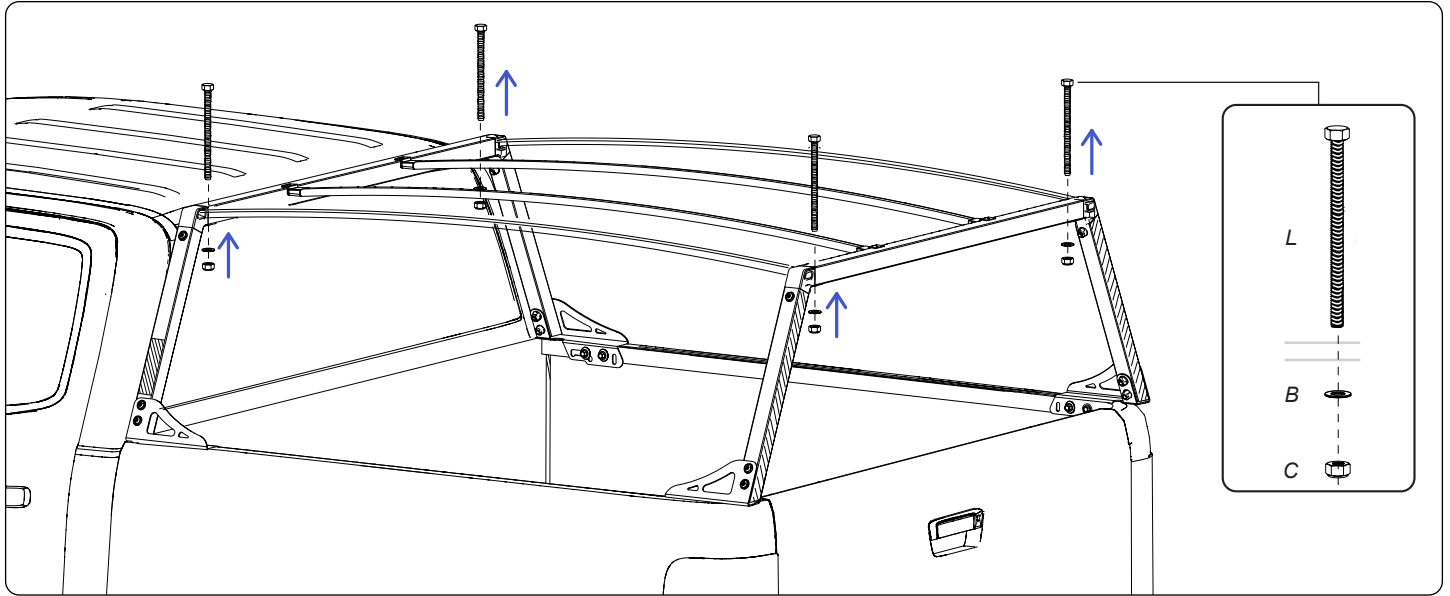

Then place the canopy cover on the frame and locate the holes in tube to be poked in through the cover.

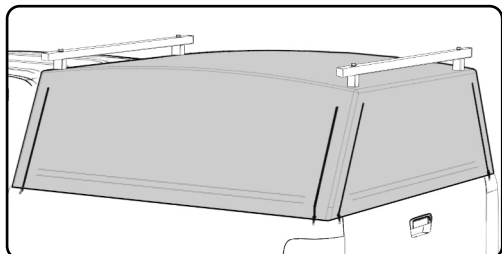
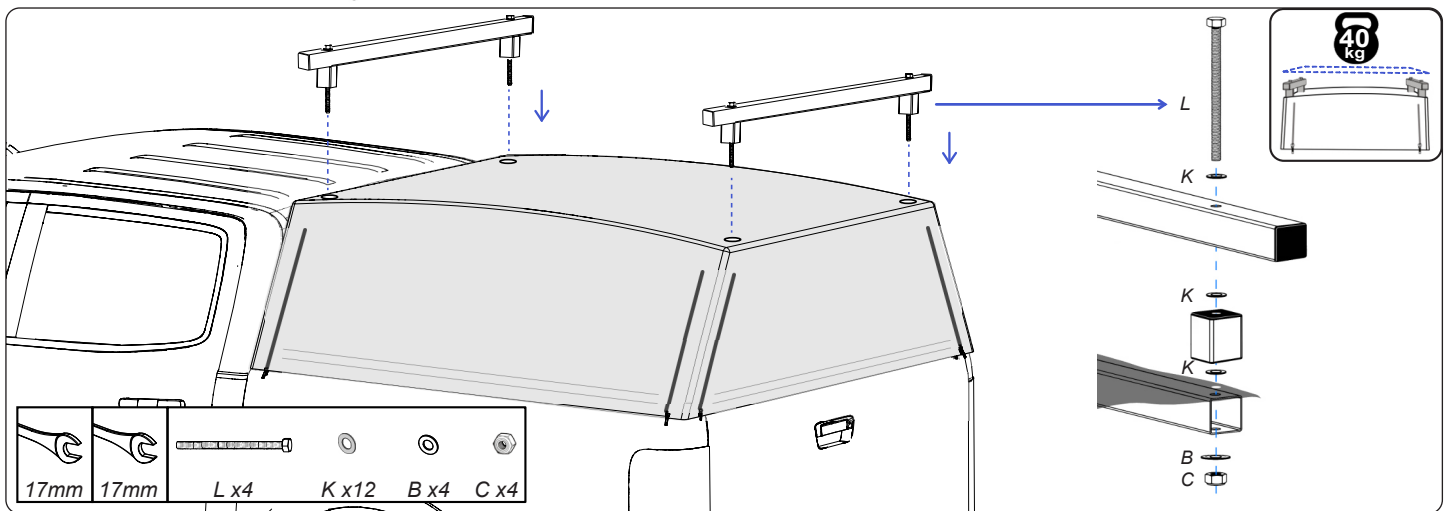
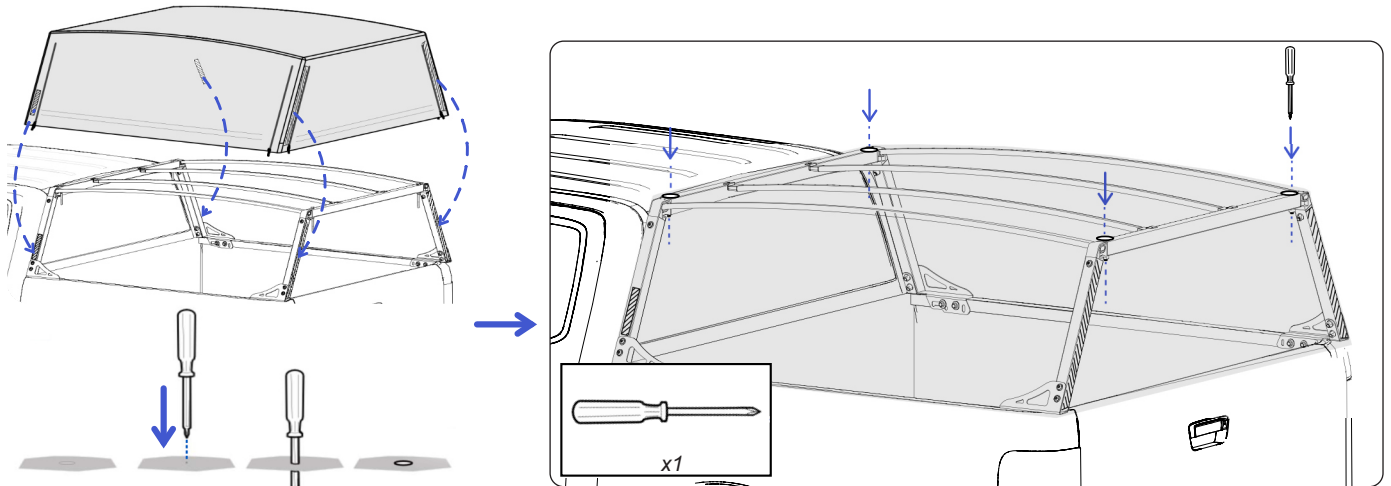

Go to **page 7** to complete canopy cover attachment...

HOW TO ATTACH THE FRONT OF CANOPY TO TUB -

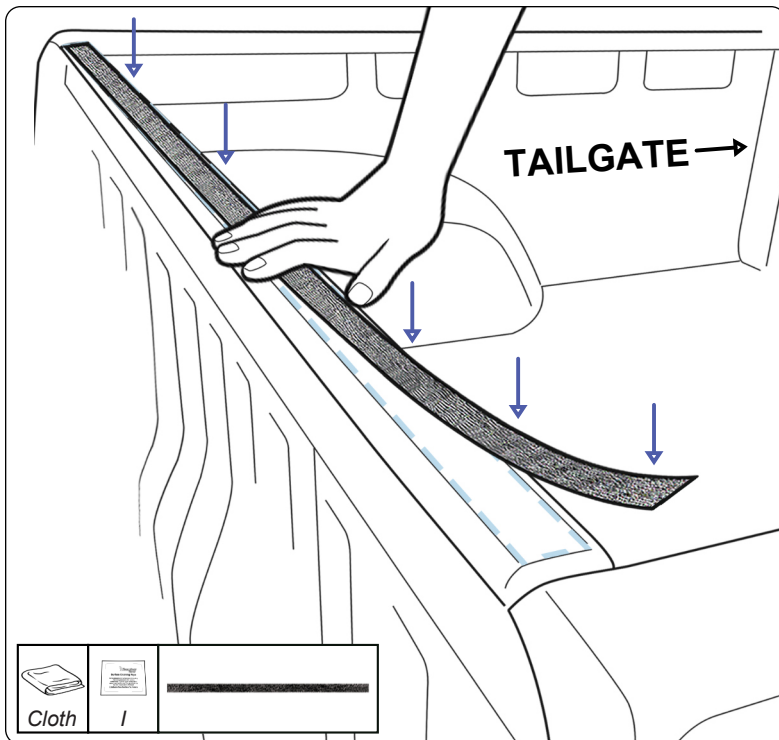

Clean any dust or dirt from top front edge of UTE tub with clean cloth and then wipe down with surface cleaning wipe. Let the surface dry. Then apply Velcro strip with **even firm pressure**. **Allow to cure for 24 hours for full bond strength.**

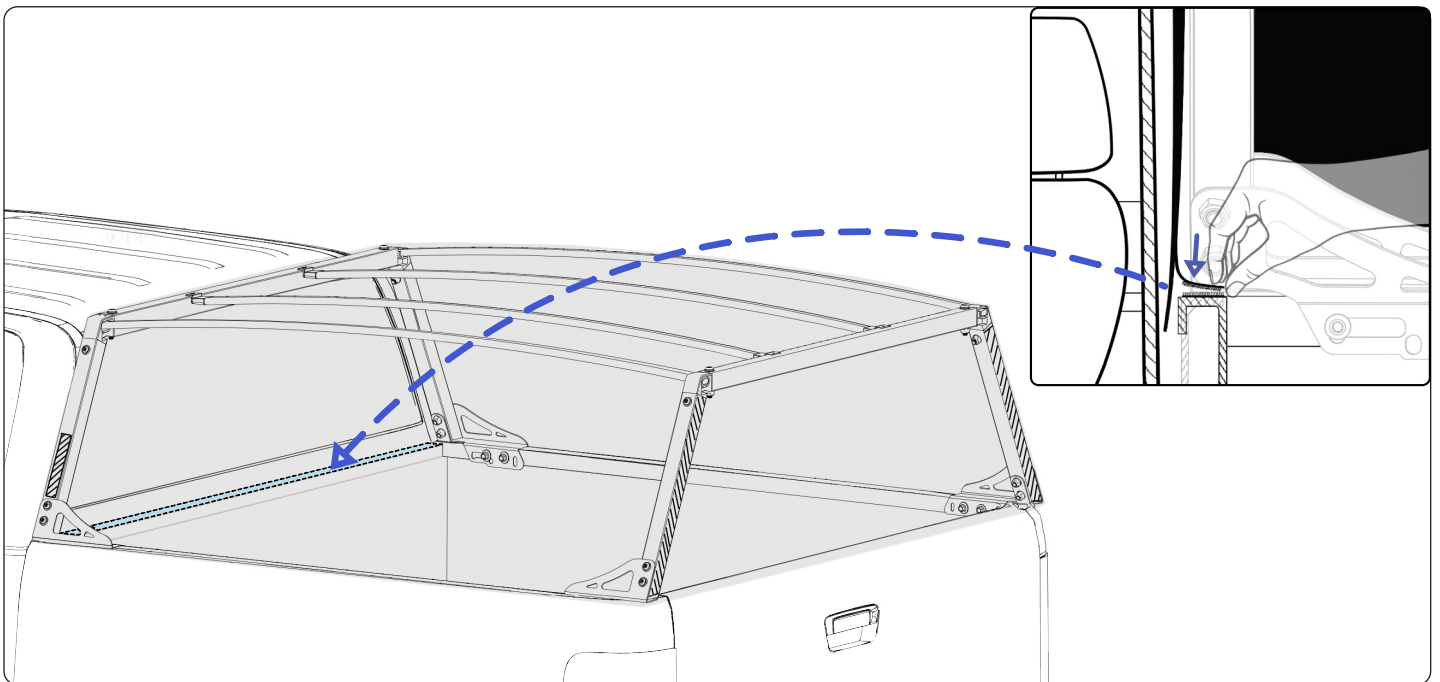

Return to **page 5** to complete canopy installation...

INSTRUCTIONS FOR USE

Send Us A Photo of your Wildback!

Happy with how your canopy turned out?
Please send us a photo to: sales@aussietonneaus.com.au



Safety -

- Ensure the Canopy tethering system is installed correctly before driving.
- Regularly check the tightness of the fasteners.
- Load must be evenly distributed and adequately secured.
- Do NOT exceed 40kg load on Ladder Racks.
- Ensure the canopy is completely closed before driving.

Load carrying requirements and recommendations -

- The load must be evenly distributed over the area of the Ladder Rack system, and the center of gravity of the load kept as low as possible. Loads which overhang the ends of the carrier system must conform to any relevant laws or by-laws in your area, and shall be adequately secured.
- Loads must be adequately secured using suitable straps or similar tightening and locking devices. The security of the load and roof load carrier shall be checked after loading and regularly throughout the journey. Elastic straps must not be used. The user is warned to maintain and to use straps in working order.
- It is recommended that items which may produce significant lifting forces (surfboard, sailboard...) are carried in such a way that lifting force is minimized, securing them independently to the front and rear of the vehicle using straps or other methods which are capable of withstanding the lifting forces. Elastic straps must not be used.
- The handling characteristics of a vehicle (in particular crosswind sensitivity, handling on bends and braking) change when a carrier system is fitted and especially if that system is loaded. Driving techniques should be altered to allow for these changes, speed reduced, especially on bends, and braking distances made greater.