

Clip On Soft Tonneau

Mitsubishi Triton

Dual Cab

2024 Onwards

(Without Sports Bars).

Part Number: ATC01804

Installation instructions.





Please note before Fitment:

- Read all instructions prior to fitting the Tonneau cover.
- Check that the fitting kit is complete before beginning the installation.
- If replacing any other cover all hardware must be replaced with hardware supplied.

Parts and tools.

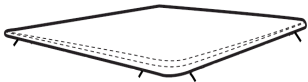
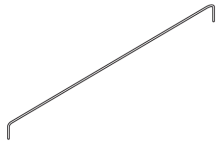
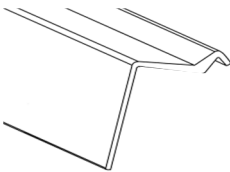
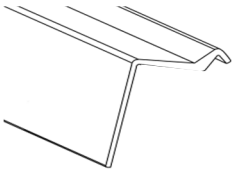
Check the contents of the kit prior to fitment.

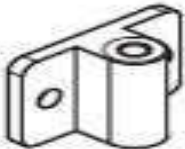
Supplied parts.

Tonneau Cover x 1	Support Bar x 1	Tailgate Rail x 1(1330mm)	Side Rails x 2 (1390mm)
			
Rope Track x 1	Brackets (300474) x 2	4mm Rivets x 25	Metal Bracket x 1
			

Step 1: Attach Rope Track

- (a) Position the flat side of the rope track centred on the top front edge of the tub with the 'C' Channel facing forward aligned with the front of the tub.
- (b) With a 4mm drill bit, Drill 5 holes evenly spaced in the rope track and into the top edge of the tub.
- (c) Place a 4mm rivet in each hole as it is drilled, but do not rivet.
- (d) Once all holes have been drilled, remove the rivets and rope track and clean any swarf away
- (e) Apply a bead of silicone to the flat face of the rope track (the edge that comes in contact with the top edge of the tub) and place the rope track back in position.
- (f) Rivet into place.

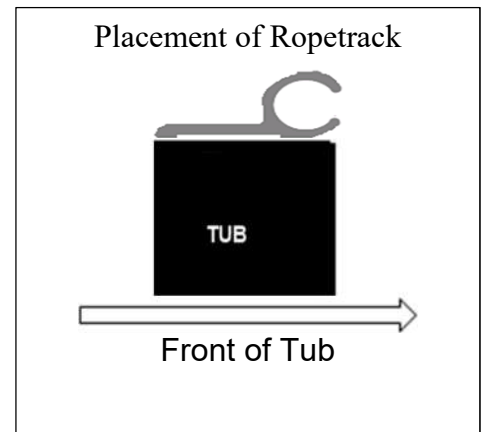

Step 1: Attach Driver Side Ally Rails

- a) Ensure the aluminium is square with the top of the tub. From the front edge of the rail, measure and mark the following locations:
 - 120mm, 425mm, 730mm, 733mm, 1000mm and 1270mm. All 30mm up from the bottom edge.
- b) Drill through those locations into tub, using 4.5 drill bit. Then rivet into 120mm, 425mm, 1000mm and 1270mm.
- c) Attach the bar bracket by placing a 4mm rivet through each hole of the bracket and into the centre holes in the rail.
- d) Rivet remaining holes (730mm and 733mm).

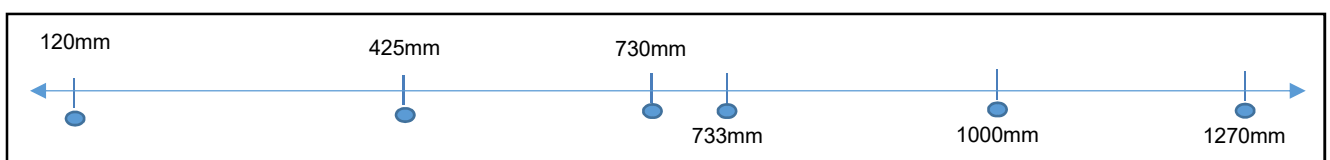
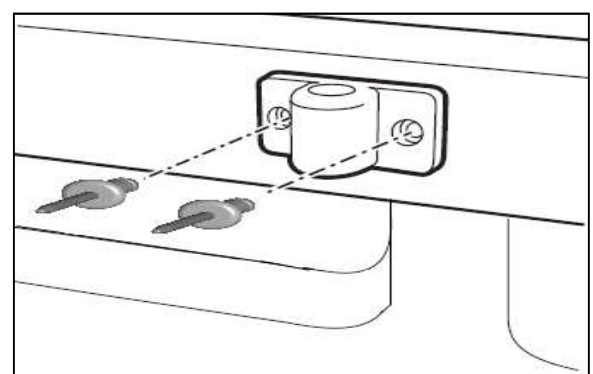
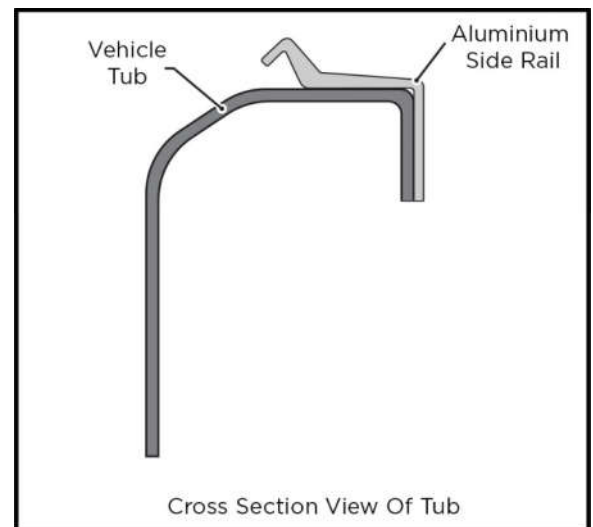

➤ **Repeat Those Instruction for Passenger's Side.**

Step 2: Attach Tailgate Rail

- a) Measure and mark the centre, and 310mm and 625mm from the centre of the rail, 30mm from the bottom edge.
- b) Position the aluminium in the centre of the tailgate, so that it is sitting square with the top surface of the tailgate.
- c) Drill through each of the holes in the aluminium rail into the tailgate.
- d) Rivet the tailgate rail to the tailgate to complete the attachment.

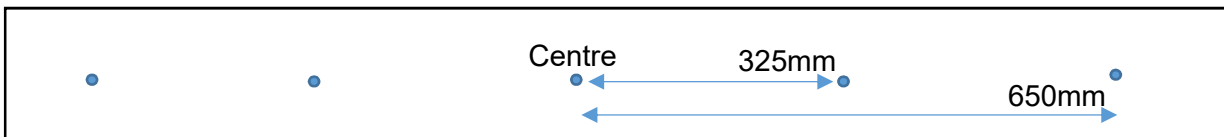
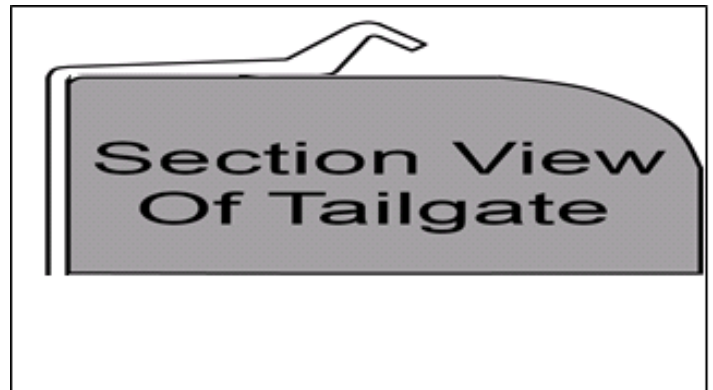

Step 3: Fit Support Bar

- a) Insert solid bar pieces into either end of hollow tube.
- b) Place the bar into the Bar Brackets and centre the hollow tube.
- c) Adjust the hollow tube so the holes are facing to the ground (this prevents the grub screws rubbing against the tonneau).
- d) Tighten the grub screws to secure the hollow tube into place.

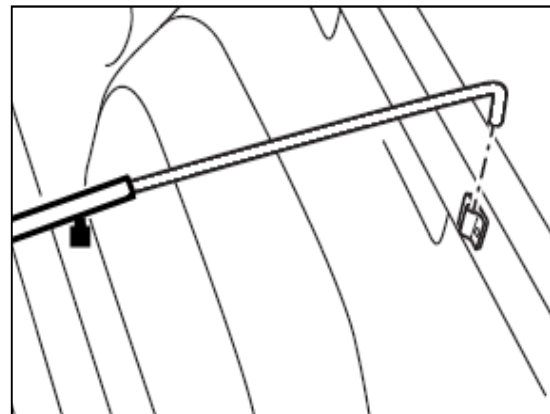

Step 4: Fit Cover

- Fit the front of the Tonneau Cover to the front of the Ute tub placing the Plastic Retainer (Fitted on the Tonneau Cover) on to the Metal Lip on the Body, between the cabin and the Ute Body. (Behind rear windscreen).
- Pull the cover under the sports bar and drape the cover across the tub.
- Clip the side plastics under the aluminium rails to stretch the cover.

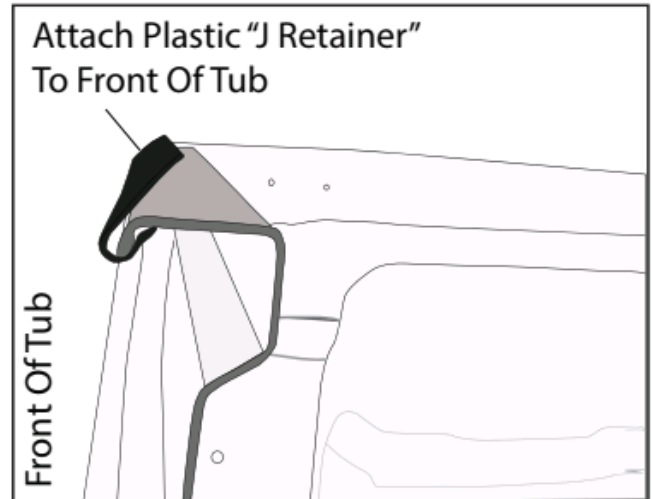

You can adjust your tonneau, to make it tighter or looser, by simply raising or lowering the height of your tonneau support bar.

Step 5. To Remove Cover Correctly

To remove cover once fitted peel cover away from aluminum clip in rail by peeling away from the edge of the plastic.

IMPORTANT: Do not use cover corners to lift. Always use plastic edges.

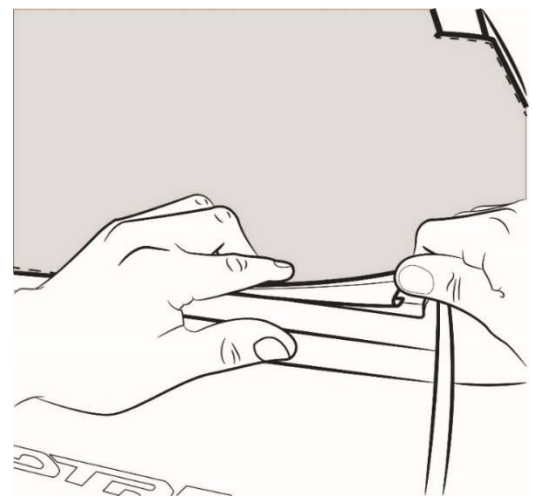

How to Fit Internal Elastic Shock Cord

To be used for covering larger loads

- Tie a knot in one end of the shock cord.
- Pull shock cord through all plastic hooks.
- Feed the shock cord through loops on the cover.
- Tie a knot at the other end.
- Space the hooks as required.
- Use washers to tie off rope.

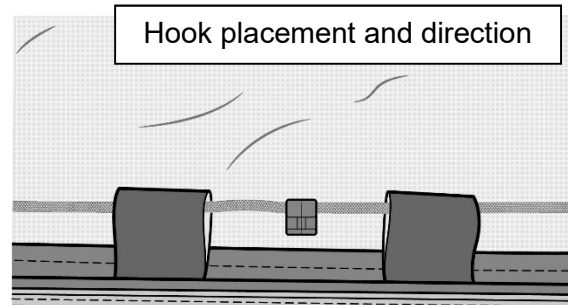
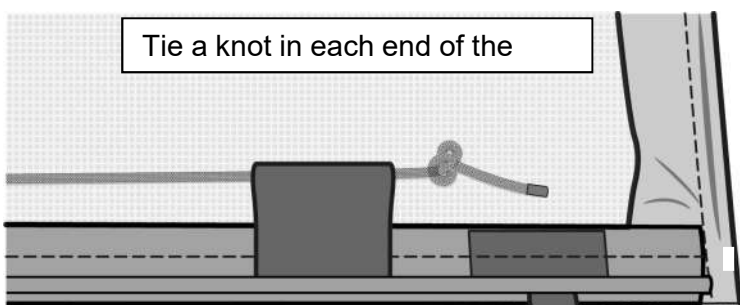
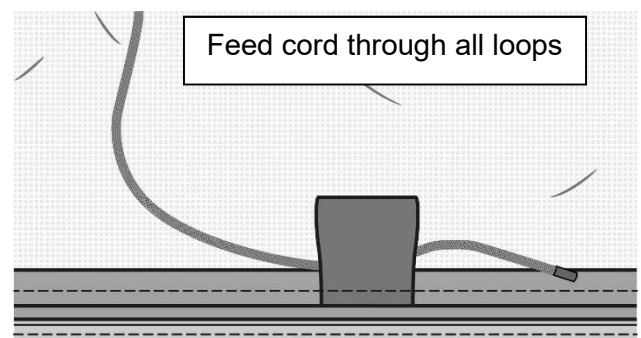

Tonneau Cover Tethering System



- **Rivet the extra Metal Bracket to the Front Driver Side Rail.**
- **Untie the end of the rope of the Cover and loop it through the Metal Bracket.**
- **Rethread the Washer and tie the end of the rope into a knot.**