

Fitting Instruction

Roll Up Soft Tonneau Cover

Part No. ATC01725

LDV T60/ T60 Max Dual Cab

With Sailplane Sport Bar Model

Installation Instruction

Please note before fitment:





- Read all instructions prior to fitting the Tonneau cover.
- Check that the fitting kit is complete before beginning the installation.
- If replacing any other cover all hardware must be replaced with hardware supplied.

Safety Notes



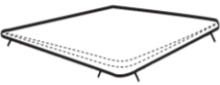
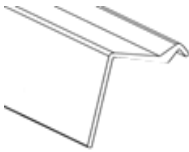

- Ensure that appropriate Personal Protective Equipment is used.
- Always refer to vehicle's work shop manual when removing components.



Parts Supplied

Tonneau Cover x 1	Tailgate Rail x 1	Side Rails x 2	Support Bars x 2	Rivets x 5
				
Rust Inhibitor x 1				
				

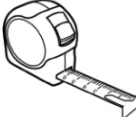
Tools Required

Drill	Pop Rivet Gun	Tape Measure	Pencil/ Marker	4mm Drill Bit
				

1. Attach Side Rails & Support Bars

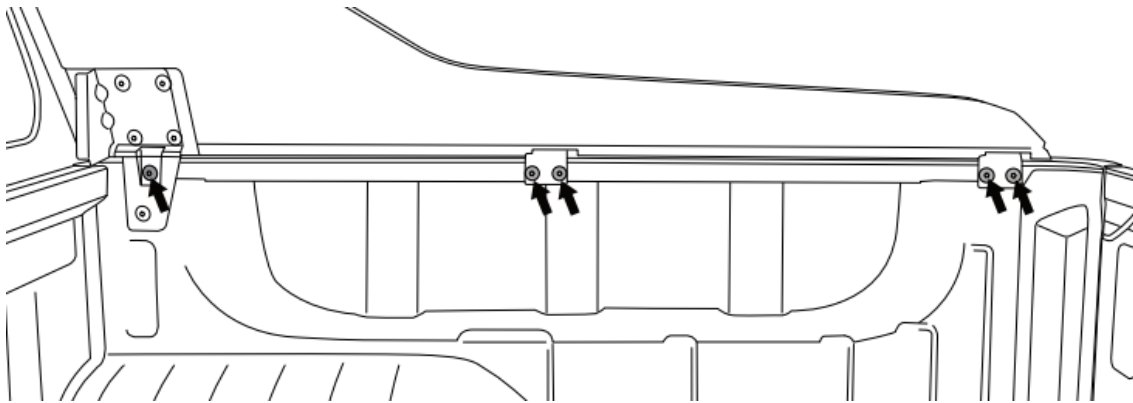

Figure 1

- a. Remove five factory screws pointed above with T45 torx bit. *Figure 1*

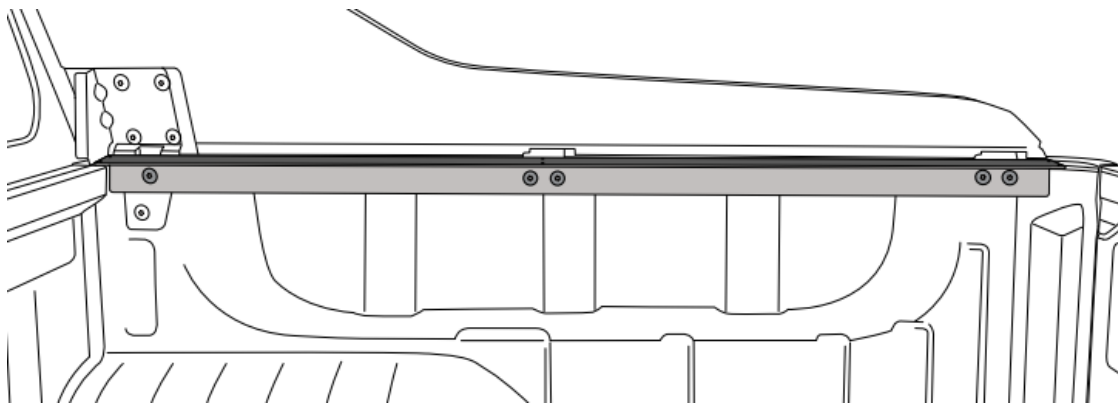

Figure 2

- b. Attach side rail using the same factory screws with T45 torx bit. *Figure 2*
- c. Repeat for the other side.

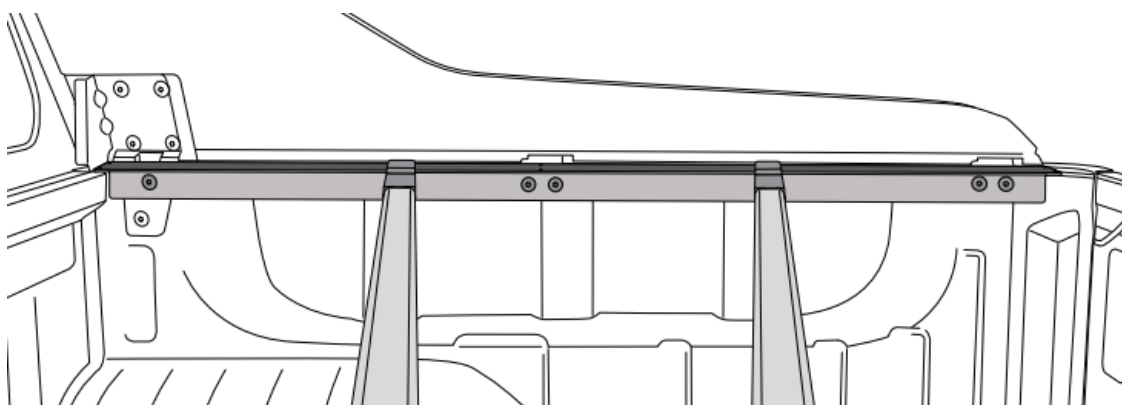

Figure 3

- d. Place the two Support Bars with even distance from the middle of tub as shown above. Velcro on both ends of the Support Bars makes it easy to adjust the distance between them along the velcro surface on the Side Rail . Adjust them as required. *Figure 3*
- e. Make sure the two support bars are seated in place with good velcro contact by pushing lightly on the centre of the two Support Bars.

2. Attach Tailgate

- Centre the aluminium rail on the tailgate and mark the tailgate for future reference (see Figure 4).

Figure 4

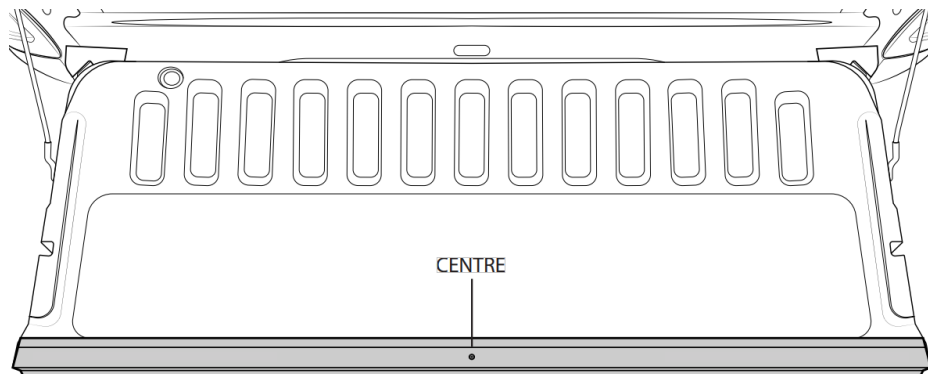

- Measure and mark all 5 points on the aluminium rail (see Figure 5) then drill out all 5 using a 4mm drill bit. We recommend drilling just the aluminium rail in this step.

Figure 5

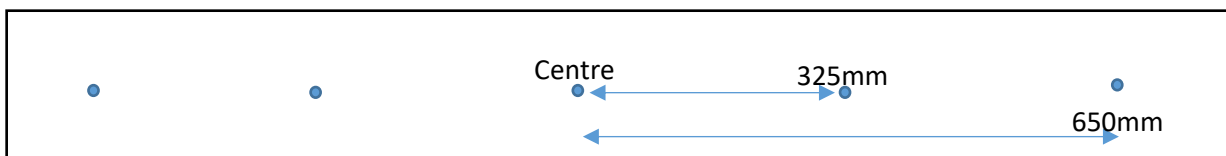

- With the aluminium now drilled, place it back onto the tailgate and re-centre, aligning with the previously measured centre mark.
- Drill through all 5 holes into the tailgate with the 4mm drill bit.
- Utilising the rivets provided, use your rivet gun to rivet the rail in at all 5 locations.

3. Fit The Tonneau Cover

- Attach the plastic J Retainer on front of the Tonneau Cover to front lip of the Ute tub located behind the cab window.
- Engage the back of the cover first, followed by the velcro on sides.

Note: Ensure the support bar is fitted underneath the Tonneau Cover to prevent water ingress and to keep the cover tight.

- Use the pull tabs to assist whenever you open or close your cover.

