

Fitting Instruction

Clip On Soft Tonneau Cover

Part No. ATC01659

**LDV T60 Mega Tub
Without Sport Bar Model
Under Rail Liner/ Spray On Liner**

Installation Instruction

Please note before fitment:







- Read all instructions prior to fitting the Tonneau cover.
- Check that the fitting kit is complete before beginning the installation.
- If replacing any other cover all hardware must be replaced with hardware supplied.

Safety Notes

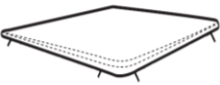
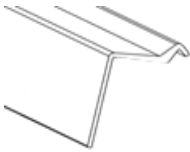
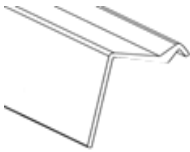



- Ensure that appropriate Personal Protective Equipment is used.
- Always refer to vehicle's work shop manual when removing components.



Parts Supplied

Tonneau Cover x 1	Tailgate Rail x 1	Side Rail x 2	Support Bar x 2	Support Barbrack x 4
				
Rivets x 30	Shock Cord x 1 Rope Hook x 5 Washer x 2	Metal Bracket x 1		
				

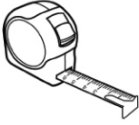
Tools Required

Drill	Pop Rivet Gun	Tape Measure	Pencil/ Marker	4mm Drill Bit
				

1. Attaching Side Rail

- a. Locate the Side Rail (1710mm) hard up against the front edge of the tub with the notch to the rear with the aluminium square with the top of the tub. *Figure 1*
- b. From the notch edge of the rail, measure and mark the following locations:
 - 30mm, 235mm, 440mm, 472mm, 660mm, 850mm, 1040mm, 1072mm, 1275mm and 1480mm. 28mm up from the bottom edge of the rail.

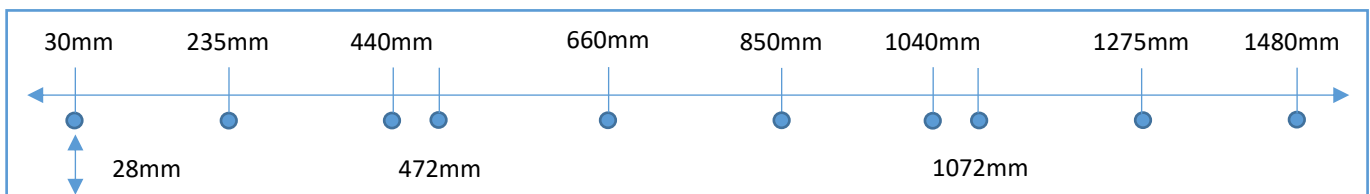
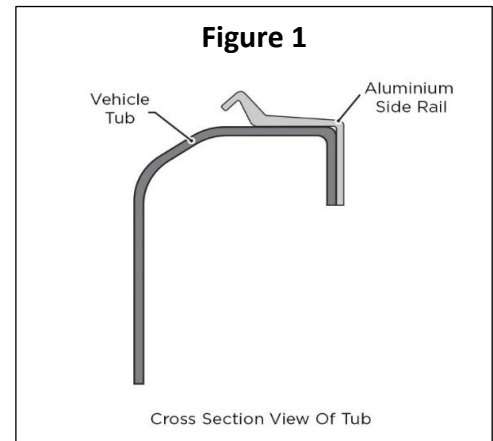

- c. Drill through those locations into tub, using 4.5 drill bit. Then rivet into 30mm, 235mm, 660mm, 850mm, 1275mm and 1480mm.
- d. Attaching the bar brackets by placing a 4mm rivets through each holes of bracket and into the centre holes in the rail.
- e. Rivet remaining holes 440mm & 472mm and 1040mm & 1072mm. *Figure 2*
- f. Repeat those steps for the other side rail.

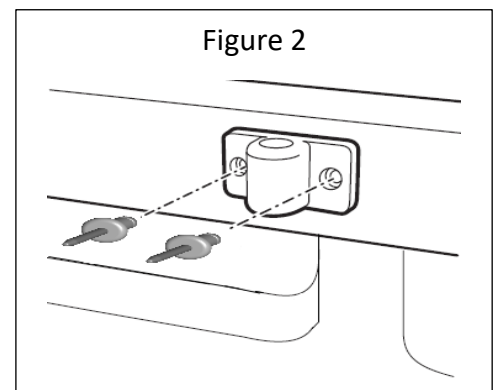

2. Attaching Support Bar

- a. Undo grub screws on the hollow tube, then insert solid bar pieces into either end of hollow tube.
- b. Place the bar into the bar brackets (*see Figure 3*) and centre the hollow tube in the middle of the tub.
- c. Adjust the hollow tube so the screws are facing the tub floor. This prevents the grub screws rubbing against the tonneau cover.
- d. Tighten the grub screws to secure the hollow tube into place.

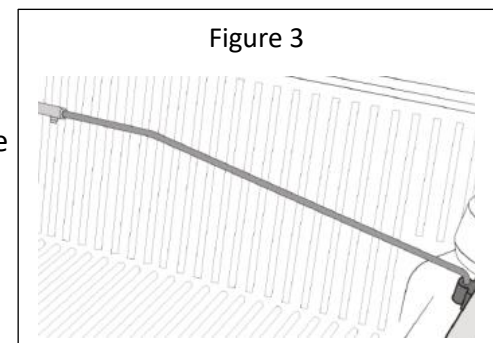

3. Attaching Tailgate

- a. Centre the aluminium rail on the tailgate and mark the tailgate for future reference (see Figure 4).

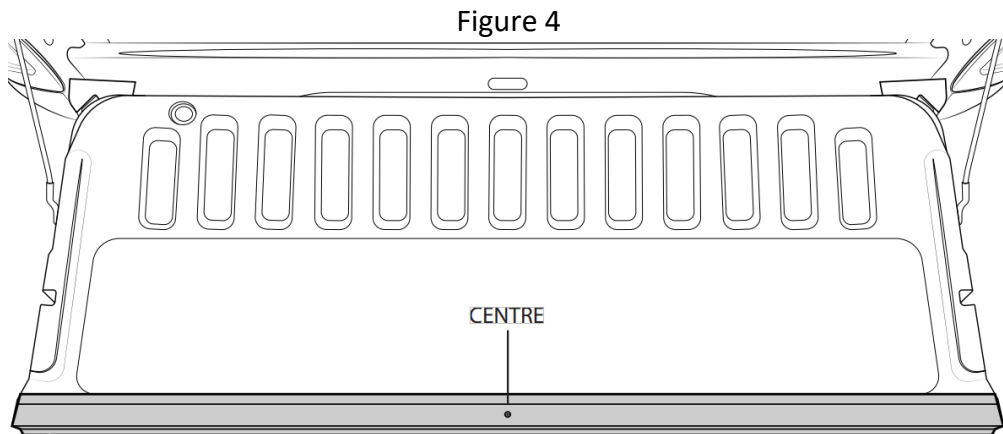

- b. Measure and mark all 5 points on the aluminium rail (see Figure 5) then drill out all 5 using a 4mm drill bit. We recommend drilling just the aluminium rail in this step.

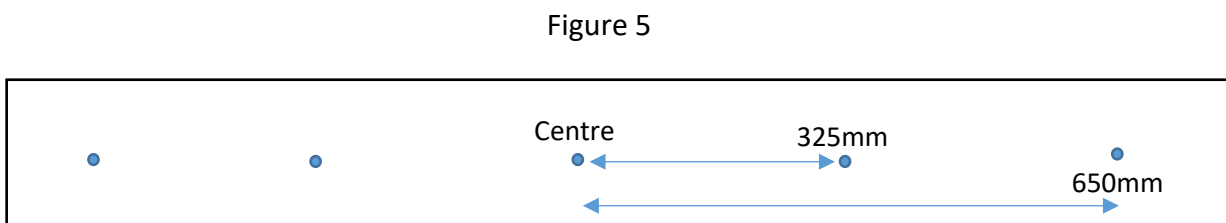

- c. With the aluminium now drilled, place it back onto the tailgate and re-centre, aligning with the previously measured centre mark.
- d. Drill through all 5 holes into the tailgate with the 4mm drill bit.
- e. Utilising the rivets provided, use your rivet gun to rivet the rail in at all 5 locations.

4. Fit The Tonneau Cover

- a. Fit the front of the Tonneau Cover to the front of the Ute tub placing the Plastic Retainer (Fitted on the Tonneau Cover) on to the Metal Lip on the Body, between the cabin and the Ute Body. (Behind rear windscreen). *Figure 6*
- b. Pull the cover under the sports bar and drape the cover across the tub.
- c. Clip the side plastics under the aluminium rails to stretch the cover.
- d. You can adjust your tonneau, to make it tighter or looser, by simply raising or lowering the height of your tonneau support bar.

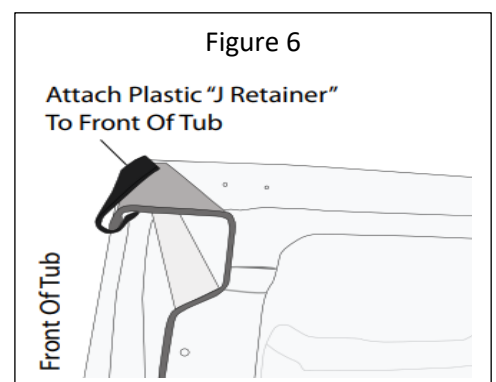

- e. To remove cover once fitted peel cover away from Aluminium clip in rail by peeling away from the edge of the plastic. Figure 7
- f. Do not use cover corners to lift. Always use plastic edges.

Figure 7

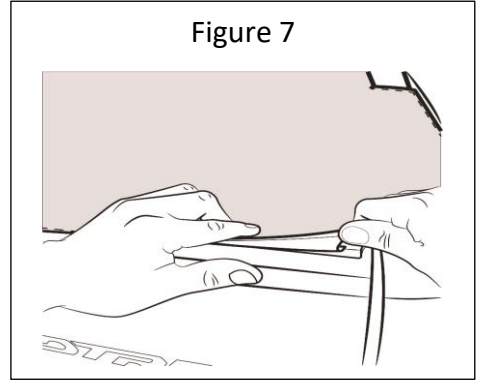

5. How To Fit Internal Shock Cord

- a. Tie a knot in one end of the shock cord
- b. Pull shock cord through all the plastic hooks.
- c. Feed the shock cord through the loops on the cover.
- d. Tie a knot at the other end.
- e. Space the hooks as required.
- f. Use washers to tie off the shock cord.

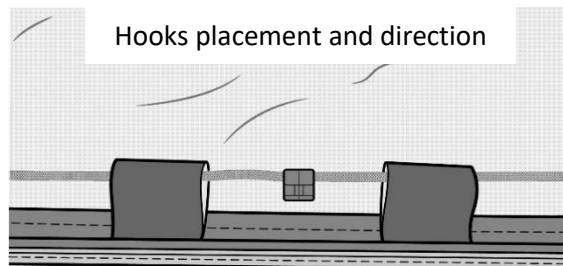
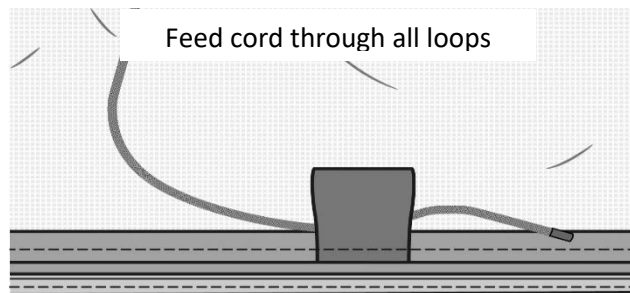
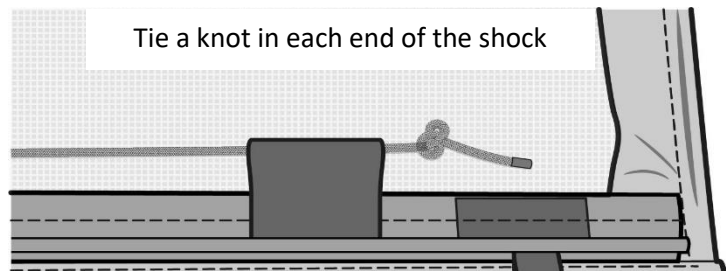

6. Tonneau Cover Tethering System

- Rivet the extra Metal Bracket to the Front Driver Side Rail.
- Untie the end of the rope of the Cover and loop it through the Metal Bracket.
- Rethread the Washer and tie the end of the rope into a knot.

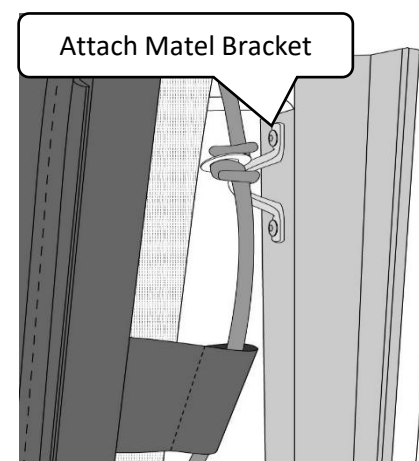

7. Warranty And Feedback

Send us A Photo Of Your Fitted Cover

Happy with how your tonneau turned out? Please email us a photo of your ute to: sales@aussietonneaus.com.au



Please try and replicate this angle when taking a photo – thanks in advance for contributing!

How To Easily Attach & Detach Your Clip On Cover



No more ugly pull tabs, tearing covers, or needing Arnold-like strength with this method!

- Visit the following link: <http://bit.ly/AT-CLIP>
- Or simply scan the QR code. Open your camera app and point it here to see the video! → → →

