

# Tonneau Cover Fitting Instructions

## Clip On Tonneau Cover for GWM Vanta Dual Cab With Extended Sport Bars 2020 – Current Part number: ATC01635

### Package includes

1 x Tonneau Cover	2 x Bar Bracket
1 x Tailgate Centre Rail	26 x 4 mm Rivet
2 x Tailgate Outer Rails	1 x Support Bar
6 x Side Rails (3 Each Side)	1 Rope, 5 x Hooks, 2 x Washers
	1 x Fitting instructions

# 1. TONNEAU COVER FITTING

## NOTE

Read entire instructions prior to start. Apply rust inhibitor to all drilled holes prior to riveting.

## 1.1 BASIC TOOL REQUIRED

Drill, 4mm Drill Bit, Rivet Gun, Marking Pencil / Pen

## 1.2 TONNEAU COVER INSTALLATION PROCEDURE

### Fit Side Rails

1. Clean the top surface of the tub sides with a damp rag and allow to dry.
2. Slide the profile down keeping the surface square with the top of the tub and the vertical face of the aluminium square with the inside edge of the tub. **See Figure 1**
3. For the front rail, mark & drill the front rail 50mm in from each end, 30mm up from the bottom of the aluminium.

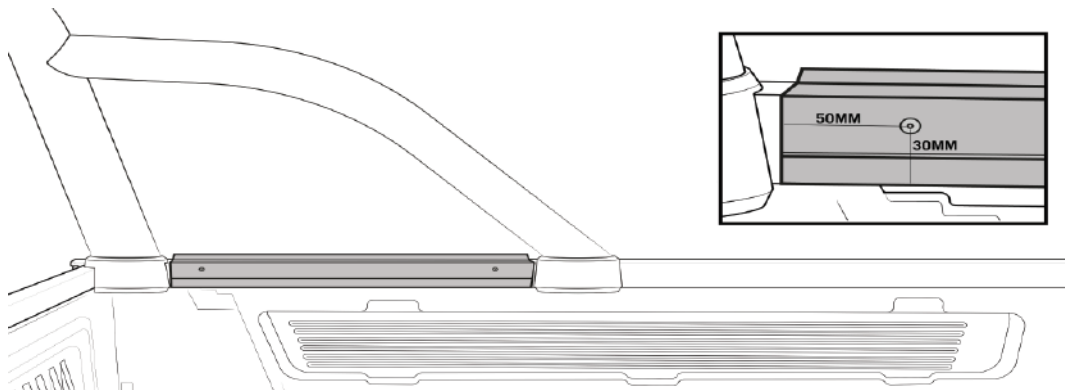
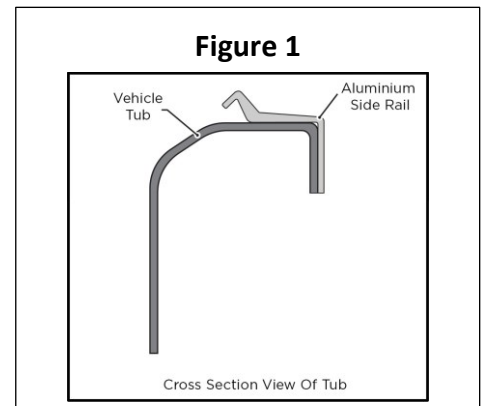

4. For the middle side rail, mark & drill the rail at 50mm, 250mm, 283mm, and 480mm, 30mm up from the bottom of the aluminium. Measuring from the front of the rail in car position.
5. Drill each of the marked locations through the aluminium and into the inside edge of the tub.
6. Attach the bar bracket into the middle rail by placing a 4mm rivet through each hole of the bracket and into the holes located at 160 and 193mm of the rear side rail. Rivet into place. **See Figure 3**
7. Rivet the rest of the holes to complete attachment of side rails.
8. Repeat those steps for the opposite side of vehicle.
9. For the rear side rail, mark & drill 20mm in from each end, 30mm up from the bottom of the aluminium.

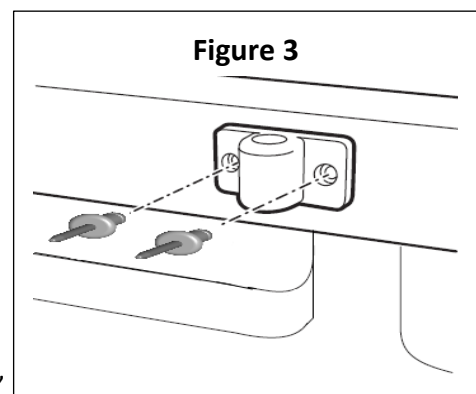

## Fit Tailgate Rail

10. Clean the top surface of the tailgate with a damp rag and allow to dry.
11. Mark & drill two 320mm tailgate pieces 50mm in from each edge, 30mm up from the top edge of the rail using a 4mm drill bit. **See Figure 3**
12. Position the 3 tailgate pieces on the tailgate **see Figure 4**. Drill through all the holes on the 3 pieces into the tailgate using a 4mm drill bit. Remove the red tape on the underside of the rails.
13. Press down firmly to ensure adhesion on each length. Rivet the 3 lengths of tailgate rail to the tailgate to complete the attachment.. **See Figure 4 & 5**
14. Fit the adjustable support bar, **refer to Section 2**.

## Fit the Cover

**Note:** If rubber seal is fitted to front lip of tub, please remove before attempting step 14.

15. To attach the cover, fit the front of the tonneau cover to the front of the ute tub by placing the plastic retainer (located under the front of the tonneau cover) on the metal lip of the body of the vehicle, between the cabin and the tub. Ensure the cover is centred on the tub.
16. Pull the cover under the sports bar and drape the cover across the tub.
17. Clip the side plastics under the aluminium profile first using the pull loops in the corners to stretch the cover.
18. Clip the plastic on the tailgate under the aluminium profile last. **See Figure 6**

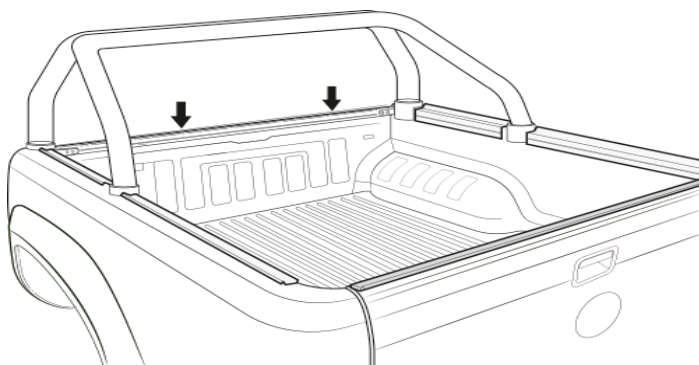

Figure 3

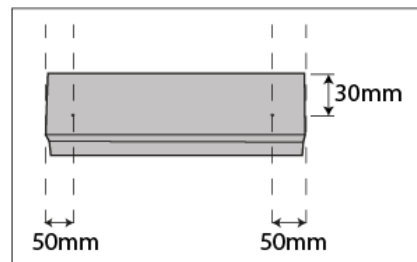

Figure 4

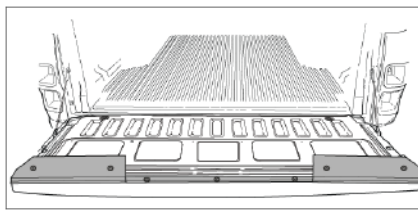

Figure 5

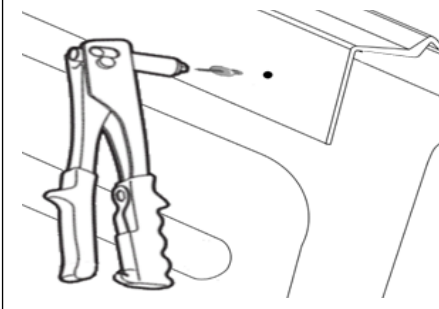
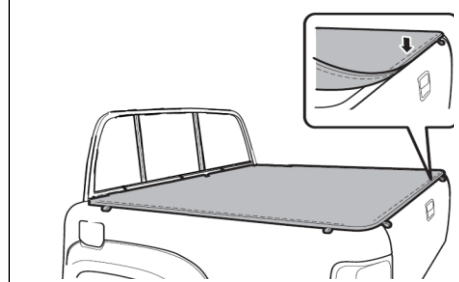
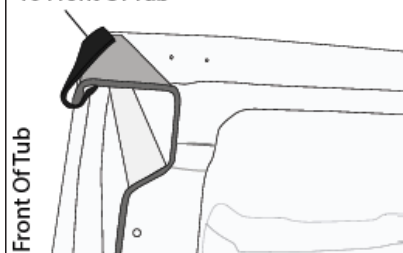

Figure 6



Attach Plastic "J Retainer"  
To Front Of Tub



### Using Internal Elastic Shock Cord:

The plastic clips on the internal shock cord can be hooked into the aluminium rails so that the cover can still be secured with larger loads in the tub.

**NOTE:** You can adjust your tonneau, to make it tighter or looser, by simply raising or lowering the height of your tonneau support bar.

## 2. ATTACHING THE SUPPORT BAR

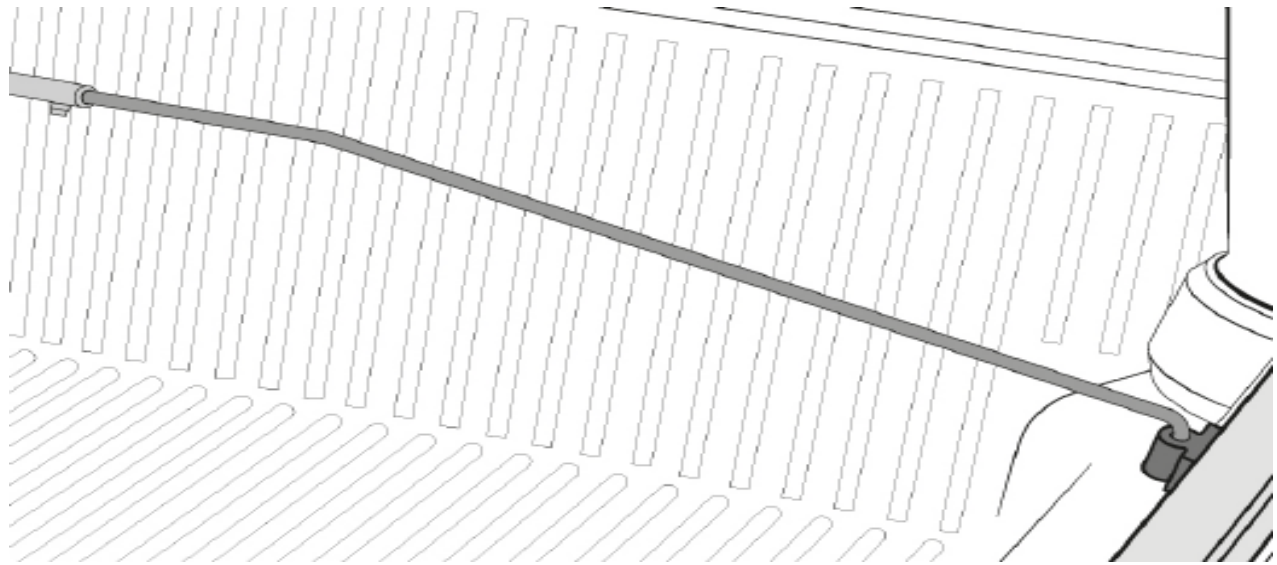

1. Undo grub screws on the hollow tube, then insert solid bar pieces into either end of hollow tube.
2. Place the bar into the bar brackets (see Diagram 5.1) and centre the hollow tube in the middle of the tub.
3. Adjust the hollow tube so the screws are facing the tub Floor. This prevents the grub screws rubbing against the tonneau cover.
4. Tighten the grub screws to secure the hollow tube into place.

# How To Fit Internal Elastic Shock Cord

The internal shock cord allows you to carry oversized items in the back of your tub without removing the tonneau cover.

- 1) Tie a knot at one end, utilise the provided washer to ensure the cord does not pull through the loops on the cover (see diagram 1.1).
- 2) Pull shock cord and hooks through the loops (see Diagram 1.2 & 1.3).
- 3) Space the hooks around your cover (see diagram 1.3). We recommend placing 3 hooks along the tailgate, 1 on left hand side, and 1 on right hand side of tub.
- 4) To finish off, tie a knot in the other end, again utilising the washer provided.

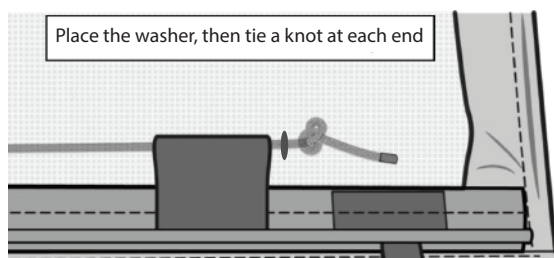
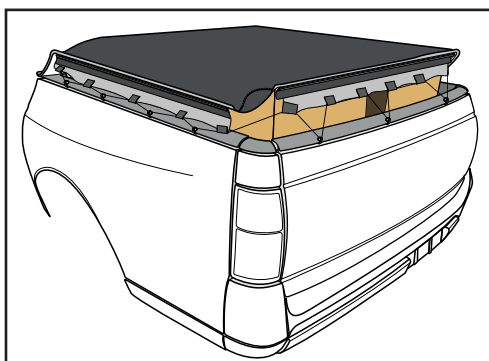

Diagram 1.1

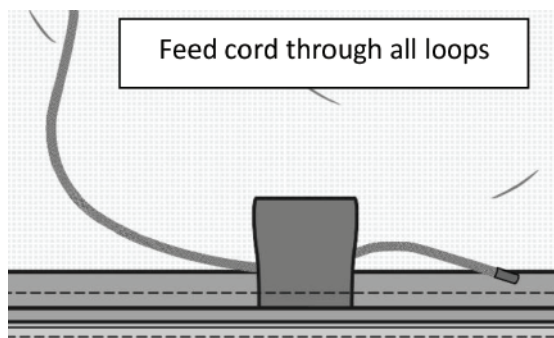

Diagram 1.2

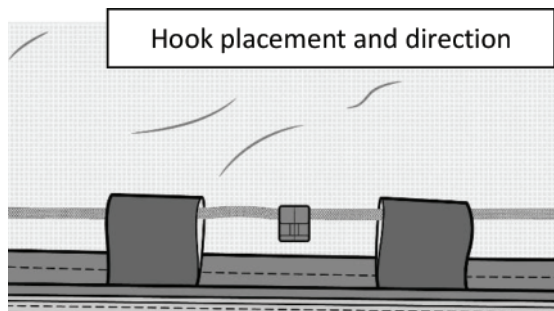
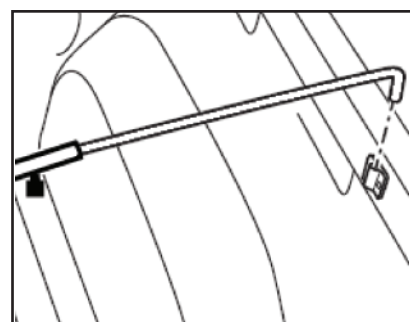

Diagram 1.3

## How To Adjust The Tension Of Your Cover

If you notice your cover is too loose/ tight and needs tensioning, you need to adjust the height of the support bar to correct this issue. To increase or decrease the height of the support bar:

- 1) Lift out one side of the support bar (see Diagram 2.1).
- 2) Undo the grub screw and adjust the length of bar until the bar is at the desired length.  
  
To **decrease** the tension: Push the bar into the hollow tube.  
To **increase** the tension: Pull the bar out from the hollow tube.
- 3) Re-tighten the grub screw and insert back into bar bracket.



# Warranty and Feedback

---

Register now to activate your 3 year warranty by filling out our online form!

QR Code:



**Website Link:** <http://www.aussietonneaus.com.au/en-au/warranty-card-request-form.html>

Thank you for purchasing an Aussie Tonneaus Product.

## Send Us A Photo Of Your Fitted Cover

---

Happy with how your tonneau turned out? Please email us a photo of your ute to: [sales@aussietonneaus.com.au](mailto:sales@aussietonneaus.com.au)



Please try and replicate this angle when taking a photo – thanks in advance for contributing!