

Fitting Instruction

Clip On Soft Tonneau Cover

Part No. ATC01586

Isuzu D-Max Dual Cab
With Factory Sport Bar Model

Installation Instruction

Please note before fitment:







- Read all instructions prior to fitting the Tonneau cover.
- Check that the fitting kit is complete before beginning the installation.
- If replacing any other cover all hardware must be replaced with hardware supplied.

Safety Notes

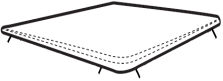

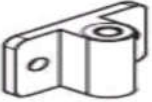

- Ensure that appropriate Personal Protective Equipment is used.
- Always refer to vehicle's work shop manual when removing components.



Parts Supplied

Tonneau Cover x 1	Tailgate Rail x 1	Rear Side Rail x 2	Front Side Rail x 2	Support Bar x 1
				
Support Bar Bracket x 2	Rivets x 20	Shock Cord x 1 Rope Hook x 5 Washer x 2		
				

Tools Required

Drill	Pop Rivet Gun	Tape Measure	Pencil/ Marker	4mm Drill Bit
				

1. Attaching Front Side Rail

- Align the inside edge of the rail (480mm) with the inside side edge of the tub with the Notched End towards the front of the tub.
- Ensure the aluminium is square with the top of the tub.
Figure 1
- Centralise the rail between the sports bars.
- Measure and mark a spot 50mm in from each end and 30mm up from the bottom edge of the rail. *Figure 2*
- Drill through these locations into the tub using a 4.5mm drill bit.
- Utilising the provided rivets, use your rivet gun to rivet the rail in place.

Repeat this step for the passenger side.

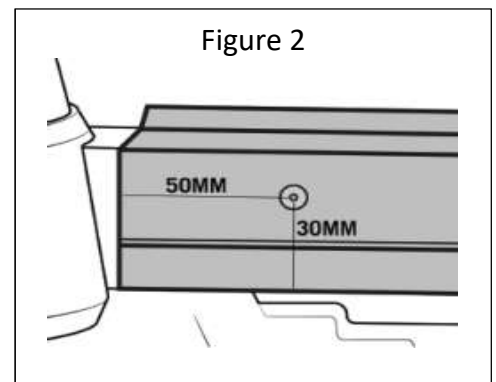
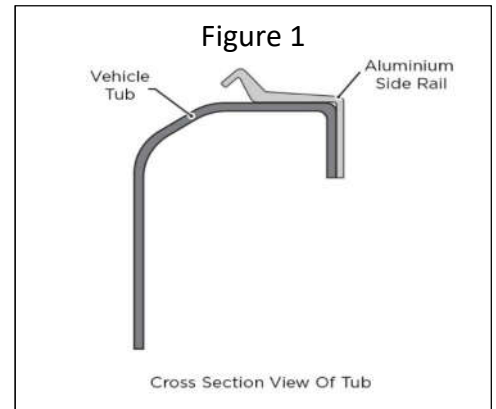

2. Attaching Rear Side Rail

- Measure and mark a spot on the rear side aluminium rail (760mm), the notch to rear, in the following locations 30mm from the bottom edge; 90, 123, 310 and 640mm (See Figure 3).

Figure 3

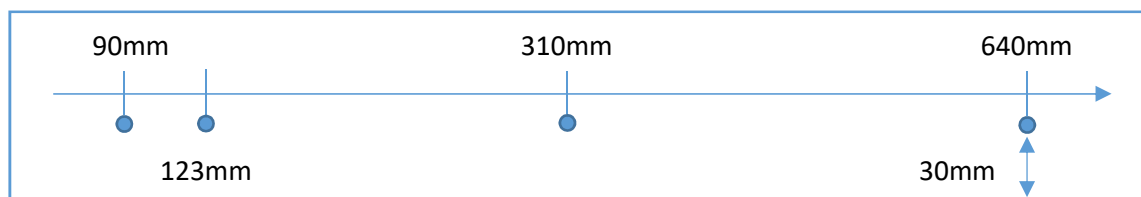

- Drill through the marked positions in the aluminium using a 4mm drill bit.
- Position the rail directly behind the sports bars, as close to the rear sports bar as possible. Ensure the aluminium is square with the top of the tub.
- Now that the aluminium is in place, drill through the holes into the tub.
- Utilising the rivets provided, use your rivet gun to rivet the rail in at the 405 & 615mm hole locations. (Do not rivet the 90mm and 123mm locations just yet).
- Repeat this step for the passenger side.

Note: The positions of the holes are reversed on the passenger side.

3. Attaching Bar Bracket and Support Bar

- a. Attach the bar bracket by placing 4mm rivets through each hole of the bracket (see Figure 4) Rivet the remaining holes (90mm and 123mm).
- b. Repeat this step for the other side.
- c. Undo grub screws on the hollow tube, then insert solid bar pieces into either end of hollow tube.
- d. Place the bar into the bar brackets (see Figure 5) and centre the hollow tube in the middle of the tub.
- e. Adjust the hollow tube so the screws are facing the tub floor. This prevents the grub screws rubbing against the tonneau cover.
- f. Tighten the grub screws to secure the hollow tube into place.

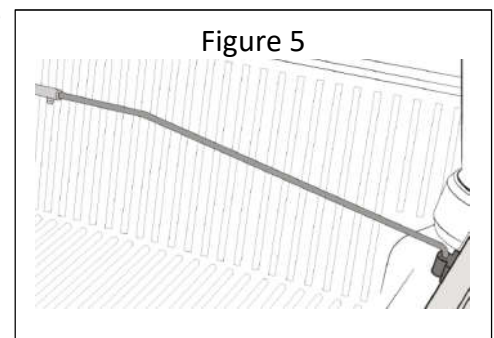
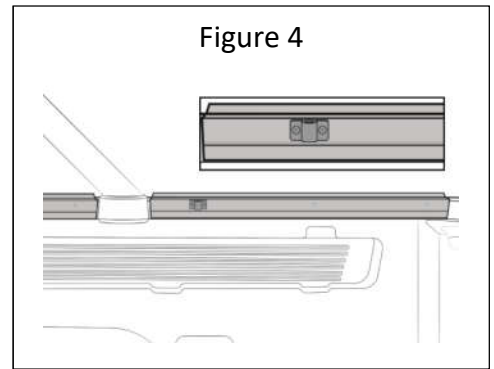

4. Attaching Tailgate

- a. Centre the aluminium rail on the tailgate and mark the tailgate for future reference (see Figure 6).

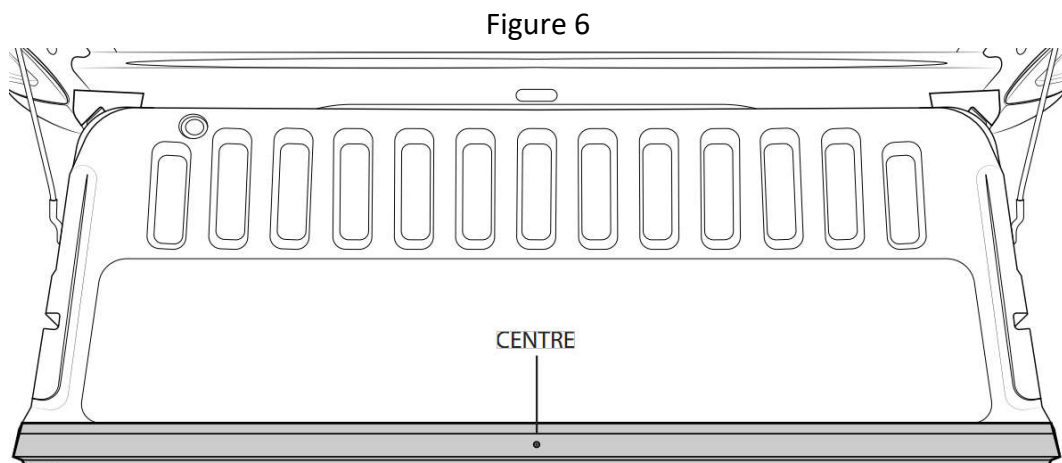

- b. Measure and mark all 5 points on the aluminium rail (see Figure 7) then drill out all 5 using a 4mm drill bit. We recommend drilling just the aluminium rail in this step.

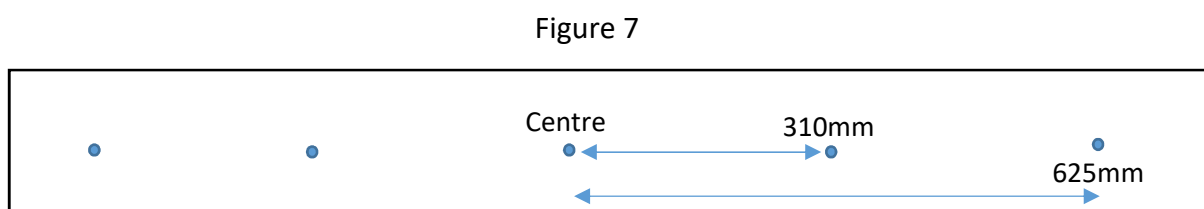

- c. With the aluminium now drilled, place it back onto the tailgate and re-centre, aligning with the previously measured centre mark.
- d. Drill through all 5 holes into the tailgate with the 4mm drill bit.
- e. Utilising the rivets provided, use your rivet gun to rivet the rail in at all 5 locations.

5. Fit The Tonneau Cover

- a. Fit the front of the Tonneau Cover to the front of the Ute tub placing the Plastic Retainer (Fitted on the Tonneau Cover) on to the Metal Lip on the Body, between the cabin and the Ute Body. (Behind rear windscreen). *Figure 8*
- b. Pull the cover under the sports bar and drape the cover across the tub.
- c. Clip the side plastics under the aluminum rails to stretch the cover.
- d. You can adjust your tonneau, to make it tighter or looser, by simply raising or lowering the height of your tonneau support bar.
- e. To remove cover once fitted peel cover away from Aluminum clip in rail by peeling away from the edge of the plastic. *See Figure 9*
- f. Do not use cover corners to lift. Always use plastic edges.

Figure 8
Attach Plastic "J Retainer"
To Front Of Tub

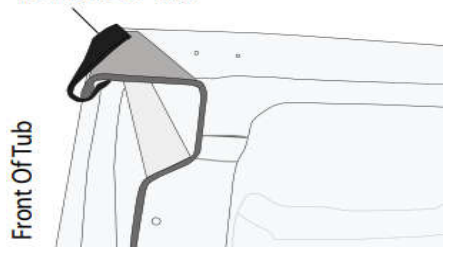
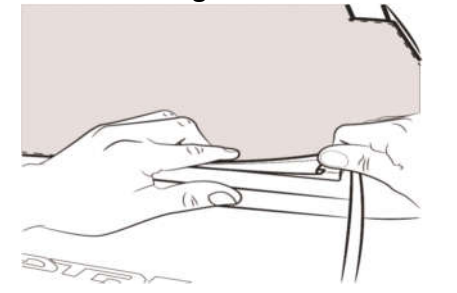

Figure 9



6. How To Fit Internal Shock Cord

- a. Tie a knot in one end of the shock cord
- b. Pull shock cord through all the plastic hooks.
- c. Feed the shock cord through the loops on the cover.
- d. Tie a knot at the other end.

Tie a knot in each end of the shock

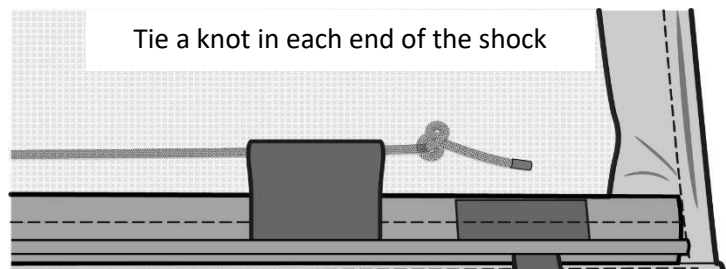

Feed cord through all loops

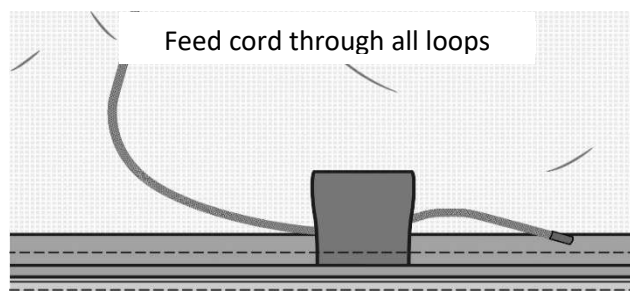

e. Space the hooks as required.

f. Use washers to tie off the shock cord.

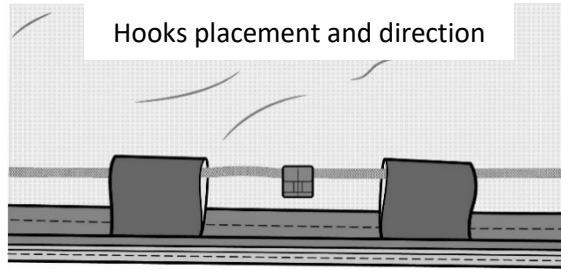

7. Warranty And Feedback

Send Us A Photo Of Your Fitted Cover

Happy with how your tonneau turned out? Please email us a photo of your Ute to: sales@aussietonneaus.com.au



Please try and replicate this angle when taking a photo – thanks in advance for contributing!

How To Easily Attach & Detach Your Clip On Cover



No more ugly pull tabs, tearing covers, or needing Arnold-like strength with this method!

- Visit the following link: <http://bit.ly/AT-CLIP>
- Or simply scan the QR code. Open your camera app and point it here to see the video! → → →

