

Fitting Instructions
Clip On Soft Tonneau

Isuzu D-Max
Space Cab
(Without Sports Bars).

Part Number: ATC01538

Installation instructions.



Please note before Fitment:

- Read all instructions prior to fitting the Tonneau cover.
- Check that the fitting kit is complete before beginning the installation.
- If replacing a previously fitted Aussie Tonneaus Cover the front rope track must be removed from the vehicle.
- If replacing any other cover all hardware must be replaced with hardware supplied.

Parts and tools.

Check the contents of the kit prior to fitment.

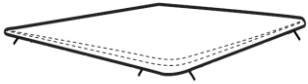
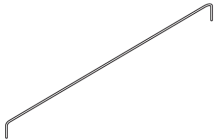
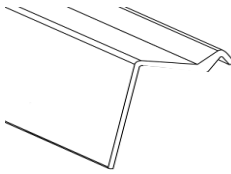
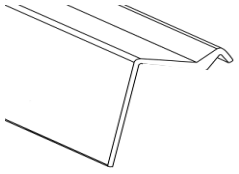
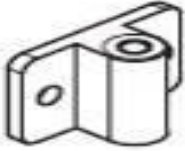
Supplied parts.

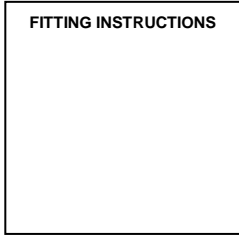
Tonneau Cover x 1	Support Bar x 2	Tailgate Rail x 1(1350mm)	Side Rails x 4(865mm)
			
Brackets (300474) x 4	4 mm Rivets x 30	Fitting Instruction	
			

Step 1: Attach Driver Side Ally Rails (865mm)

- Ensure the aluminium is square with the top of the tub. From the Notched edge of the rails, measure and mark the following locations:
 - 20mm, 225mm, 432mm, 465mm, and 740mm. All 30mm up from the bottom edge.
- Drill through those locations into tub, using 4.5 drill bit. Then rivet into 20mm, 225mm, and 740mm.
- Attach the bar bracket by placing a 4mm rivet through each hole of the bracket and into the centre holes in the rail.
- Rivet remaining holes (432mm and 465mm).
- Follow the same for the side rear aluminium.

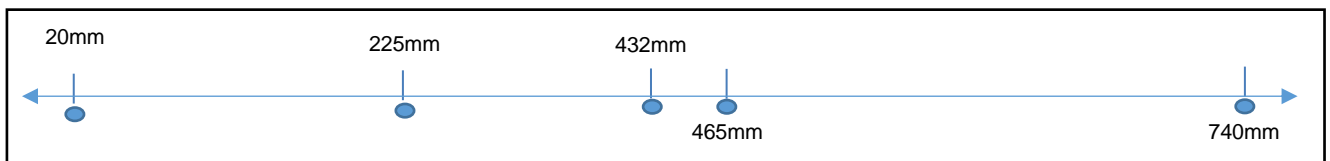
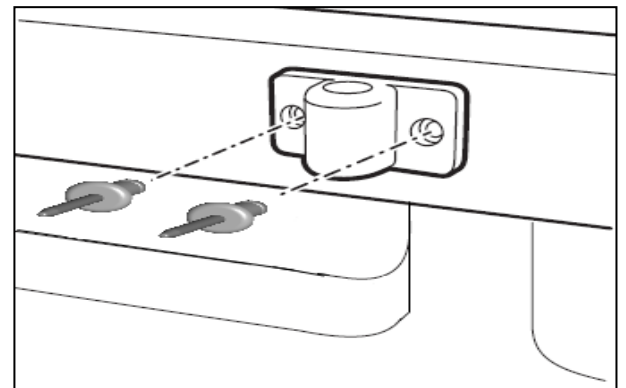
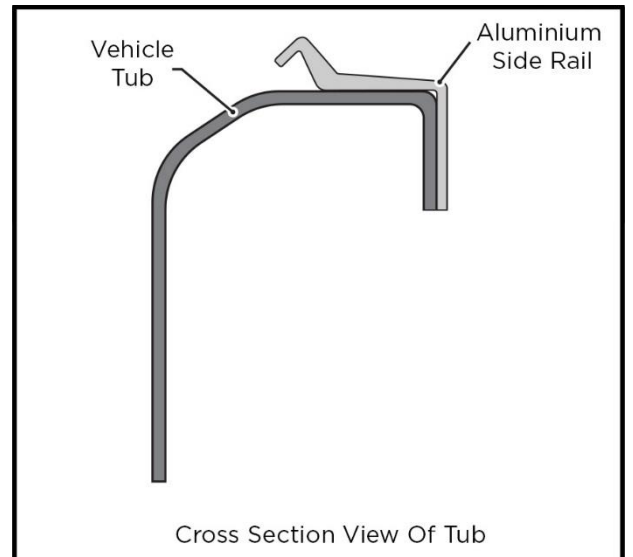

➤ **Repeat Those Instruction for Passenger's Side.**

Step 2: Attach Tailgate Rail

- Measure and mark the centre, and 310mm and 625mm from the centre of the rail, 30mm from the bottom edge.
- Position the aluminium in the centre of the tailgate, so that it is sitting square with the top surface of the tailgate.
- Drill through each of the holes in the aluminium rail into the tailgate.

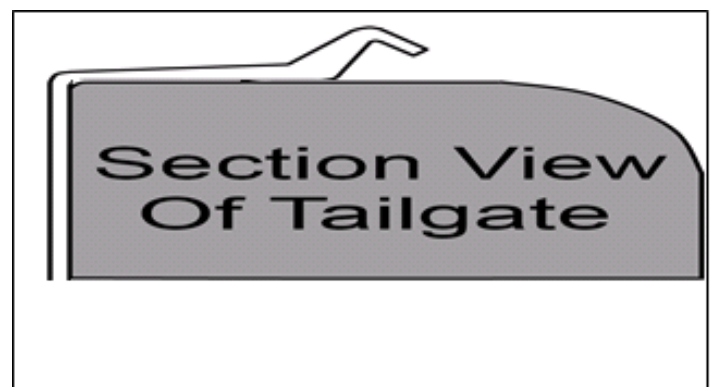

- d) Rivet the tailgate rail to the tailgate to complete the attachment.

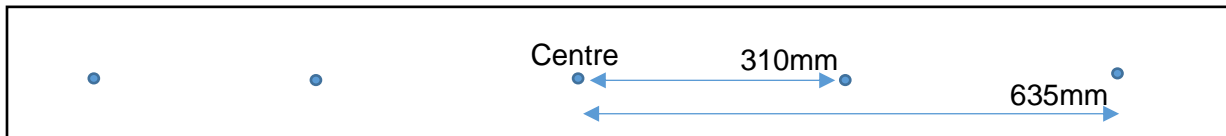

Step 3: Fit Support Bar

- Insert solid bar pieces into either end of hollow tube.
- Place the bar into the Bar Brackets and centre the hollow tube.
- Adjust the hollow tube so the holes are facing to the ground (this prevents the grub screws rubbing against the tonneau).
- Tighten the grub screws to secure the hollow tube into place.

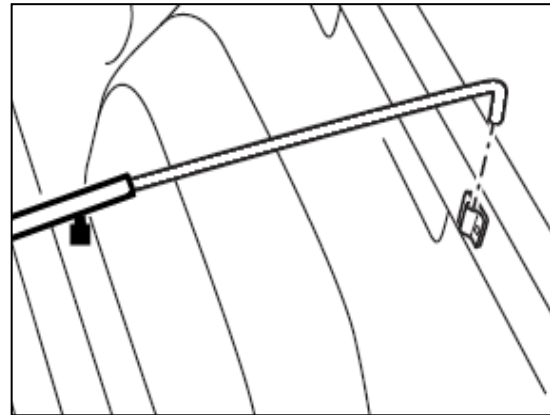

Step 4: Fit Cover

- Fit the front of the Tonneau Cover to the front of the Ute tub placing the Plastic Retainer (Fitted on the Tonneau Cover) on to the Metal Lip on the Body, between the cabin and the Ute Body. (Behind rear windscreen).
- Pull the cover under the sports bar and drape the cover across the tub.
- Clip the side plastics under the aluminium rails to stretch the cover.

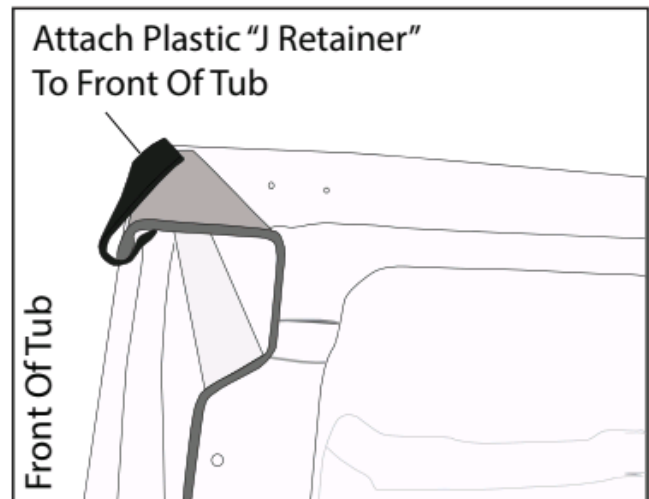

You can adjust your tonneau, to make it tighter or looser, by simply raising or lowering the height of your tonneau support bar.

Step 5. To Remove Cover Correctly

To remove cover once fitted peel cover away from aluminum clip in rail by peeling away from the edge of the plastic.

IMPORTANT: Do not use cover corners to lift. Always use plastic edges.

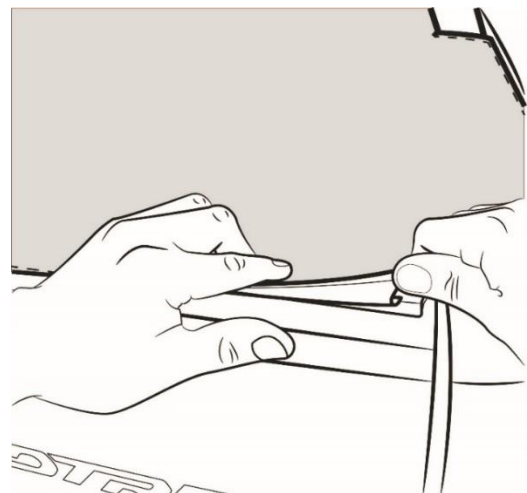

Tonneau Cover Tethering System



- Rivet the extra Metal Bracket to the Front Driver Side Rail.
- Untie the end of the rope of the Cover and loop it through the Metal Bracket.
- Rethread the Washer and tie the end of the rope into a knot.