

Tonneau Cover Fitting Instructions

Nissan Navara NP300 Dual Cab With Sports Bars

Part number: ATC01436

Package includes	
1 x Tonneau Cover	2 x Bar Bracket
2 x Front Side Rails	20 x 4 mm Rivet
2 x Rear Side Rails (Notched)	1 x Shock cord
1 x Tailgate Rail	4 x Rope Hooks
1x Rope Track	2 x Washer
1 x Support Bar	
1x Fitting Instruction	

Please note before Fitment:

- Read all instructions prior to fitting the Tonneau cover.
- Check that the fitting kit is complete before beginning the installation.

1. Attach Front Rope Track

- (a) Position the flat side of the rope track centred on the top front edge of the tub with the 'C' Channel facing forward and align the BACK of the 'C' Channel with the INSIDE edge of the Tub.
- (b) With a 4mm drill bit, Drill 5 holes evenly spaced in the rope track and into the top edge of the tub.
- (c) Place a 4mm rivet in each hole as it is drilled, but do not rivet.
- (d) Once all holes have been drilled, remove the rivets and rope track and clean any swarf away
- (e) Apply a bead of silicone to the flat face of the rope track (the edge that comes in contact with the top edge of the tub) and place the rope track back in position.
- (f) Rivet into place.

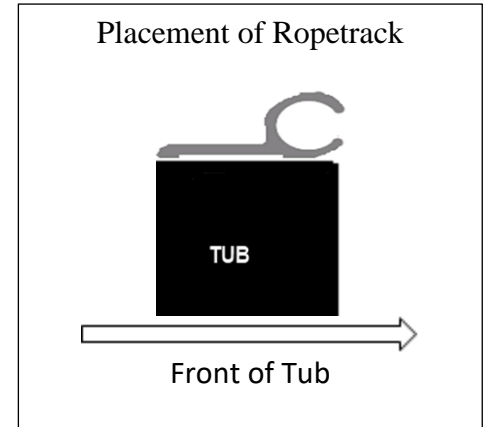

2. Attach Front Side Aluminium Rail

- (a) Centre the rail between the sports bars. Ensure the aluminium is square and flush with the top of the tub.
- (b) Measure and mark 50mm in from each end of the rails, 30mm up from the bottom.
- (c) Drill through marked locations through the aluminium and into the inside edge of the tub.
- (d) Rivet into place.

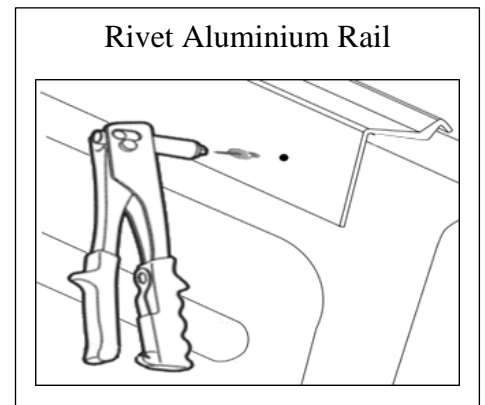

3. Attach Rear Side Aluminium Rail

(a) Position the rail behind the sports bars with the **shimmed end towards the back**. Ensure the aluminium is square with the top of the tub. From the front edge of the rail, 30mm from the bottom edge, measure and mark the following locations:

- 110mm, 143mm, 400mm and 720mm.

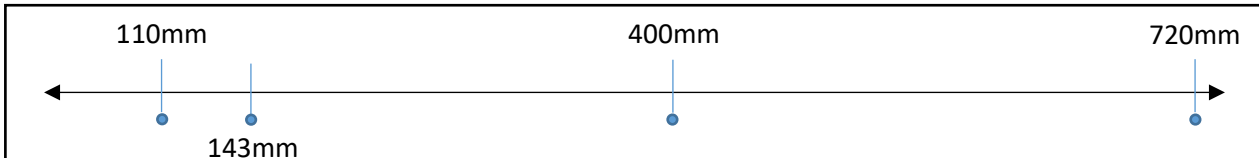

(b) Drill through these locations into the tub using a 4.5mm drill bit. Rivet into 400mm and 720mm.

4. Attach Bar Bracket

Attach the bar bracket by placing a 4mm rivet through each hole of the bracket and into the centre holes in the rail.

Then rivet remaining holes (110mm and 143mm).

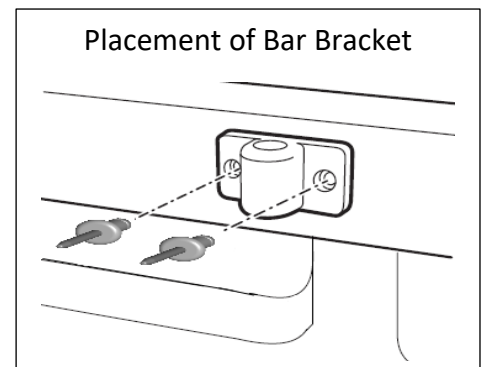

❖ Repeat instructions 2 to 4 for the other side.

5. Attach The Tailgate Aluminium Rail

(a) Measure and mark the centre of the tailgate, and 310mm and 620mm from the centre of the rail, 30mm from the bottom edge.

(b) Position the aluminium in the centre of the tailgate, so that it is sitting square and flush with the top surface of the tailgate.

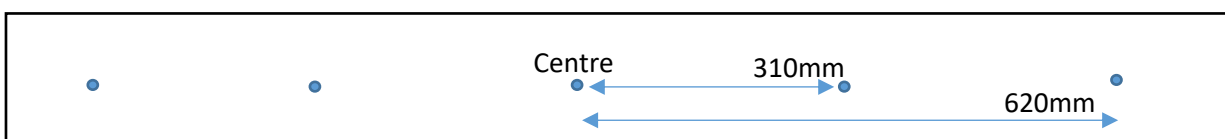
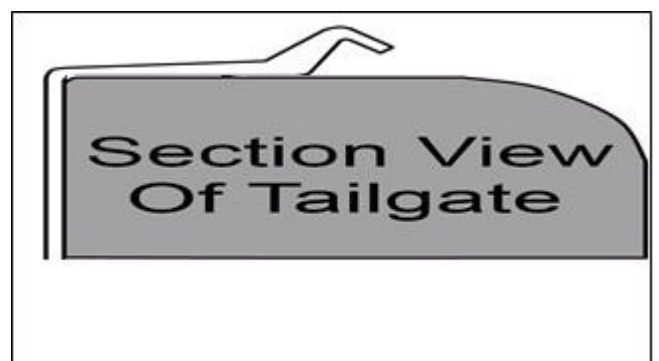

(c) Drill through each of the holes in the Aluminium rail into the tailgate. Rivet the tailgate rail to the tailgate to complete the attachment.

6. Fit Support Bar

- (a) Insert solid bar pieces into either end of hollow tube. Place the bar into the Bar Brackets and centre the hollow tube.
- (b) Adjust the hollow tube so the holes are facing to the ground (this prevents the grub screws rubbing against the tonneau).
- (c) Tighten the grub screws to secure the hollow tube into place.

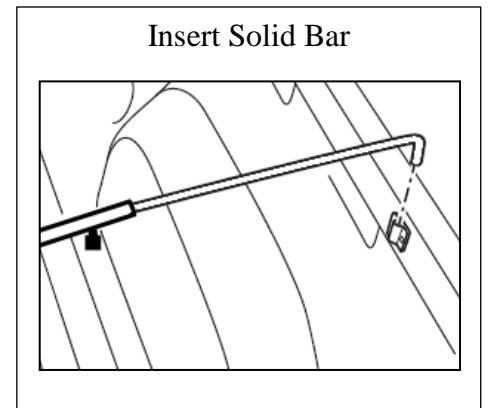

7. Fit The Tonneau Cover

- a) Fit the front of the Tonneau Cover to Rope Track on the front of the tub.
- b) Pull the cover under the sports bar and drape the cover across the tub.
- c) Clip the side plastics under the aluminium rails to stretch the cover.

To remove cover once fitted peel cover away from Aluminium clip in rail by peeling away from the edge of the plastic.

IMPORTANT: Do not use cover corners to lift. Always use plastic edges.

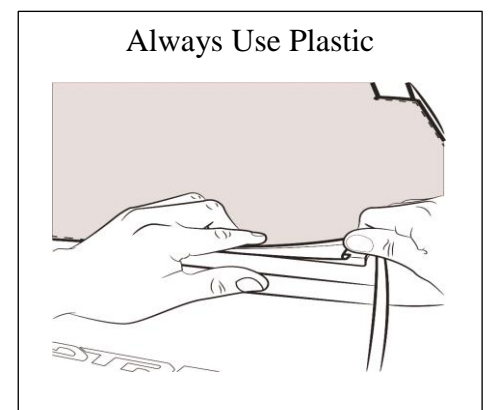

How to Fit Internal Elastic Shock Cord

To be used for covering larger loads

- Tie a knot in one end of the shock cord.
- Pull shock cord through all plastic hooks.
- Feed the shock cord through loops on the cover.
- Tie a knot at the other end.
- Space the hooks as required.

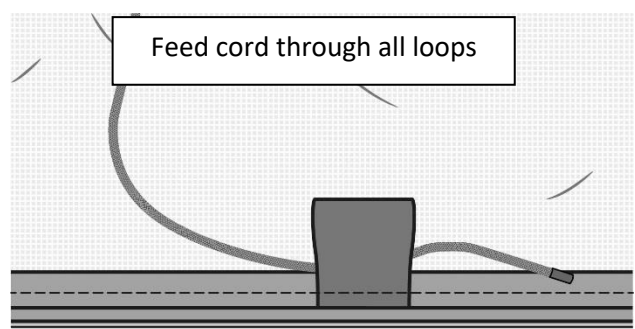

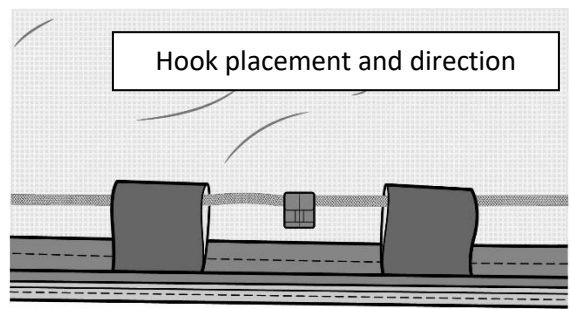
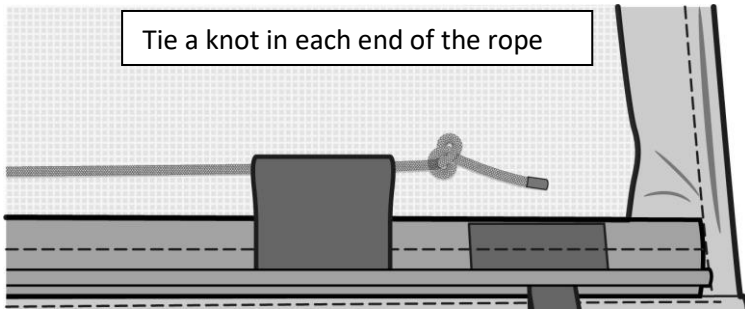

WARRANTY AND FEEDBACK

Register now to activate your 3 year warranty by filling out our online form!

QR Code:



Website Link: <http://www.aussietonneaus.com.au/en-au/warranty-card-request-form.html>

Thank you for purchasing a Aussie Tonneau Product.

How To Easily Attach & Detach Your Clip On Cover



No more ugly pull tabs, tearing covers, or needing Arnold-like strength with this method!

- Visit the following link: <http://bit.ly/AT-CLIP>
- Or simply scan the QR code. Open your camera app and point it here to see the video! → → →

