

Tonneau Cover Fitting Instructions

Isuzu D-Max Dual Cab With Sports Bars

Part number: ATC01434

Package includes	
1 x Tonneau Cover	2 x Bar Bracket
2 x Front Side Rails	20 x 4 mm Rivet
2 x Rear Side Rails (Notched)	1 x Shock cord
1 x Tailgate Rail	4 x Rope Hooks
1 x Support Bar	2 x Washer
1x Fitting Instruction	

Please note before Fitment:

- Read all instructions prior to fitting the Tonneau cover.
- Check that the fitting kit is complete before beginning the installation.

1. Attach Front Side Aluminium Rail

- (a) Centre the rail between the sports bars. Ensure the aluminium is square and flush with the top of the tub.
- (b) From the front edge of the rail, 30mm from the bottom edge, measure and mark the following locations:
 - 50mm and 280mm, 550mm and 582mm

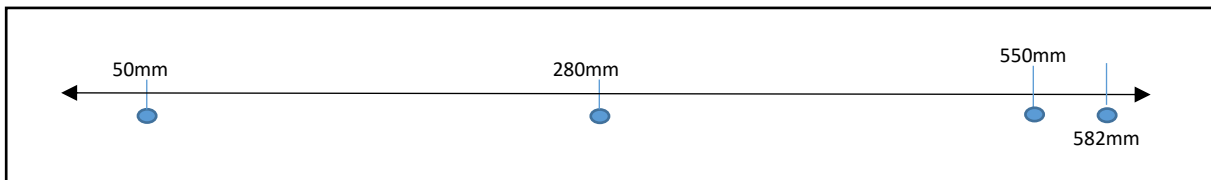

- (c) Drill each of the marked locations through the aluminium and into the inside edge of the tub.
- (d) And then rivet into 50mm and 280mm.
- (e) Attach the bar bracket by placing a 4mm rivet through each hole of the bracket and rivet into the remaining holes, 550mm and 582mm.

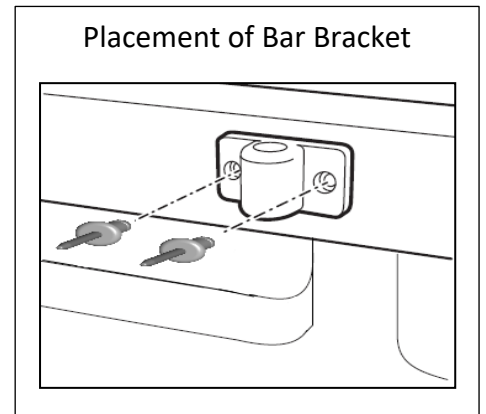

❖ Repeat those instruction for the other side.

2. Attach Rear Side Aluminium Rail

- (a) Centre the rail behind the sports bars. Ensure the aluminium is square and flush with the top of the tub.
- (b) Measure and mark a spot 50mm from each end and one in the middle, 30mm up from the bottom edge of the rail.
- (c) Drill through these locations into the tub using a 4mm drill bit. Then rivet into place.

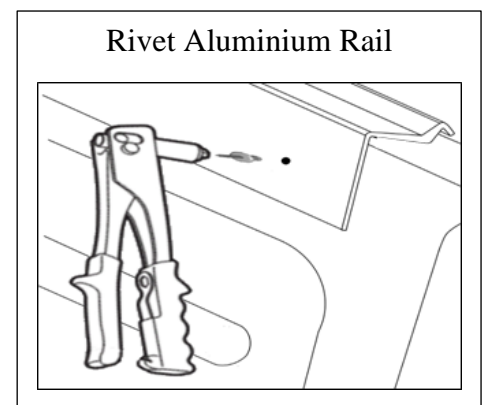

3. Attach The Tailgate Aluminium Rail

- (a) Measure and mark the centre of the tailgate, and 315mm and 625mm from the centre of the rail, 30mm from the bottom edge.
- (b) Position the aluminium in the centre of the tailgate, so that it is sitting square and flush with the top surface of the tailgate.

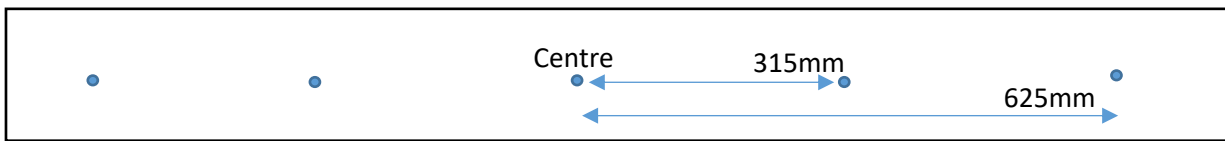
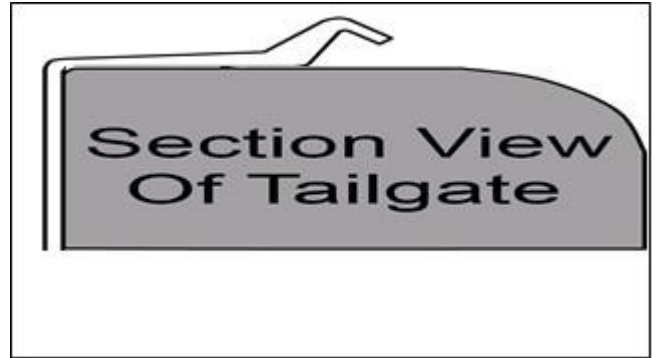

- (c) Drill through each of the holes in the Aluminium rail into the tailgate. Rivet the tailgate rail to the tailgate to complete the attachment.

4. Fit Support Bar

- (a) Insert solid bar pieces into either end of hollow tube. Place the bar into the Bar Brackets and centre the hollow tube.
- (b) Adjust the hollow tube so the holes are facing to the ground (this prevents the grub screws rubbing against the tonneau).
- (c) Tighten the grub screws to secure the hollow tube into place.

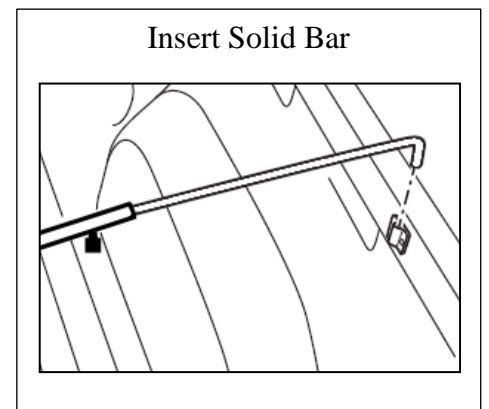

5. Fit The Tonneau Cover

- Fit the front of the Tonneau Cover to the front of the Ute tub placing the Plastic Retainer (Fitted on the Tonneau Cover) on to the Metal Lip on the Body, between the cabin and the Ute Body. (Behind rear windscreen).
- Pull the cover under the sports bar and drape the cover across the tub.
- Clip the side plastics under the aluminium rails to stretch the cover.

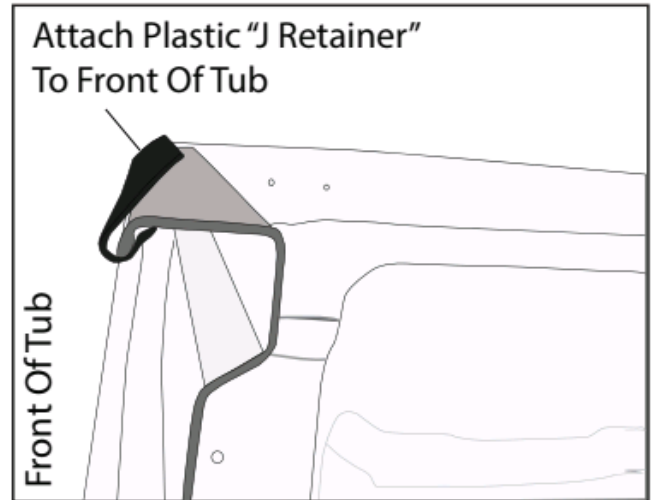

To remove cover once fitted peel cover away from Aluminium clip in rail by peeling away from the edge of the plastic.

IMPORTANT: Do not use cover corners to lift. Always use plastic edges.

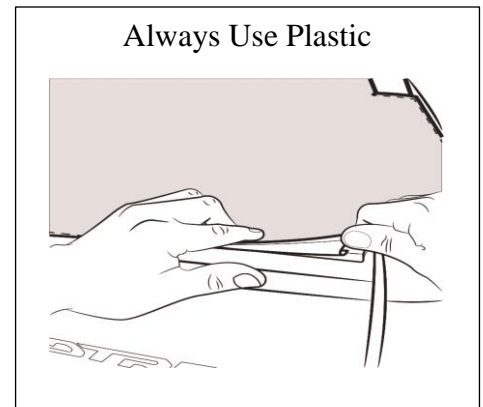

How to Fit Internal Elastic Shock Cord

To be used for covering larger loads

- Tie a knot in one end of the shock cord.
- Pull shock cord through all plastic hooks.
- Feed the shock cord through loops on the cover.
- Tie a knot at the other end.
- Space the hooks as required.
- Use washers to tie off rope.

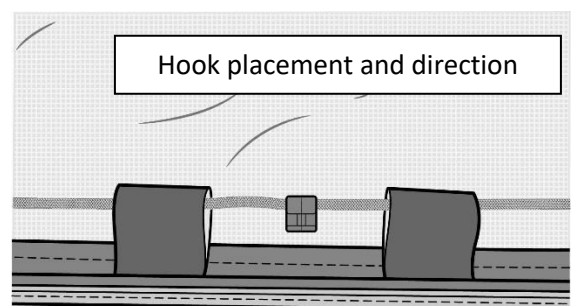
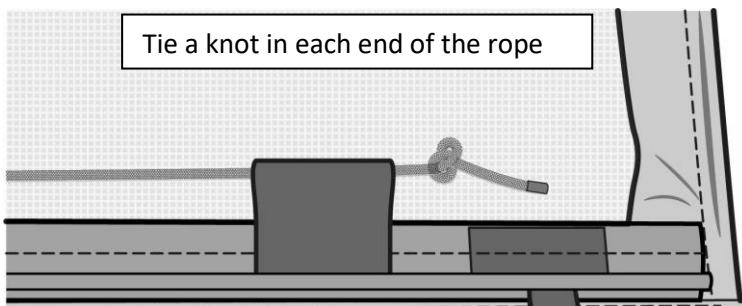
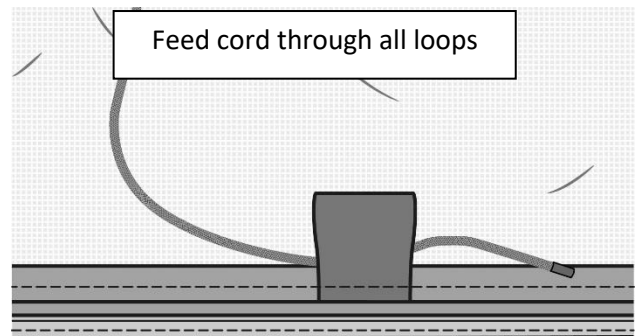

How To Easily Attach & Detach Your Clip On Cover



No more ugly pull tabs, tearing covers, or needing Arnold-like strength with this method!

- Visit the following link: <http://bit.ly/AT-CLIP>
- Or simply scan the QR code. Open your camera app and point it here to see the video! → → →

