

**Fitting Instructions**  
**Clip On Soft Tonneau**

**Ford PX Ranger**  
**Super Cab**  
(With Sports Bars).

Part Number: ATC01269

# Installation instructions.







## Please note before Fitment:

- Read all instructions prior to fitting the Tonneau cover.
- Check that the fitting kit is complete before beginning the installation.
- If replacing a previously fitted Aussie Tonneaus Cover the front rope track must be removed from the vehicle.
- If replacing any other cover all hardware must be replaced with hardware supplied.

## Parts and tools.

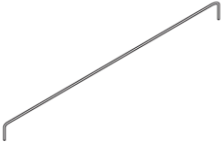
Check the contents of the kit prior to fitment.

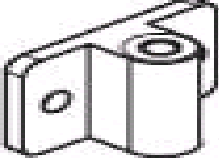
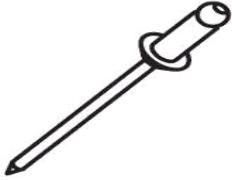
Supplied parts.

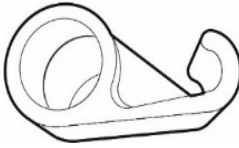
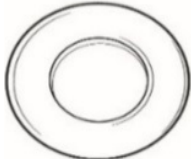
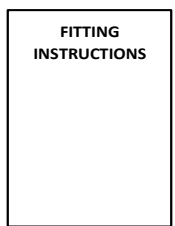
<p><b>Tailgate Rail x 1(1380mm)</b></p> 	<p><b>Rear Side Rail x 2(980mm)</b></p> 	<p><b>Front Side Rail x 2(510mm)</b></p> 	<p><b>Support Bar x 1</b></p> 
<p><b>Tonneau Cover x 1</b></p> 	<p><b>Bar Brackets x 2</b></p> 	<p><b>4mm Rivet x 21</b></p> 	<p><b>Internal Shock Cord x 1</b></p> 
<p><b>Rope Hooks x 5</b></p> 	<p><b>M8 Washer x 2</b></p> 	<p><b>Fitting Instruction x 1</b></p> 	

## Step 1: Attach Front Side Rails

- Centre the rail between the sports bars. Ensure the aluminium is square with the top of the tub.
- Measure and mark a spot 50mm in from each end and 30mm up from the bottom edge of the rail.
- Drill through these locations into the tub using a 4.5mm drill bit. Then rivet into place.

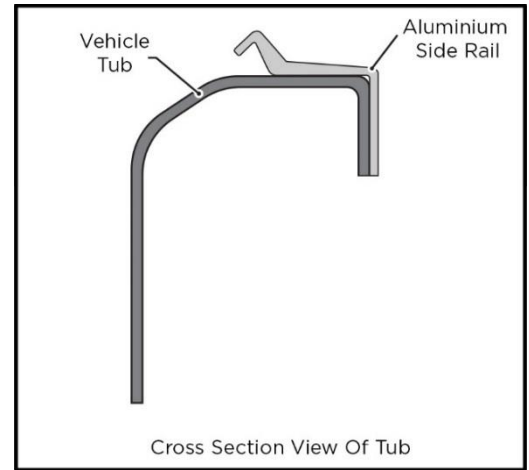

## Step 2: Attach Rear Side Rails

- Position the rail behind the sports bars. Ensure the aluminium is square with the top of the tub.
- From the front edge of the rail, 30mm from the bottom edge, measure and mark the following locations:
  - 50, 345, 475, 508, 635 and 930mm.

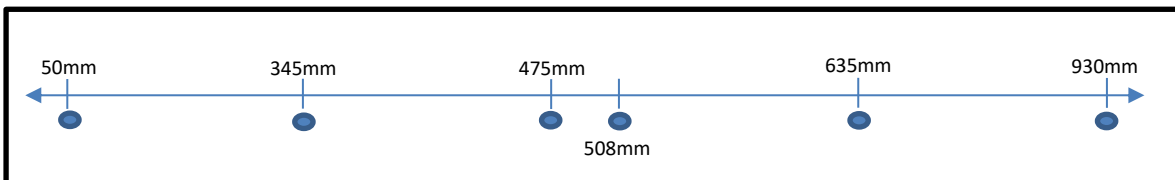
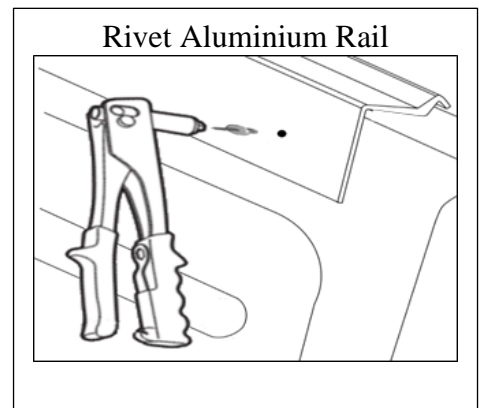

- Drill through these locations into the tub using a 4.5mm drill bit. Rivet into 50mm, 345mm, 635mm and 930mm.
- Attach the bar bracket by placing a 4mm rivet through each hole of the bracket and into the first holes behind the sports bar.
- Rivet remaining holes. (475mm and 508mm).

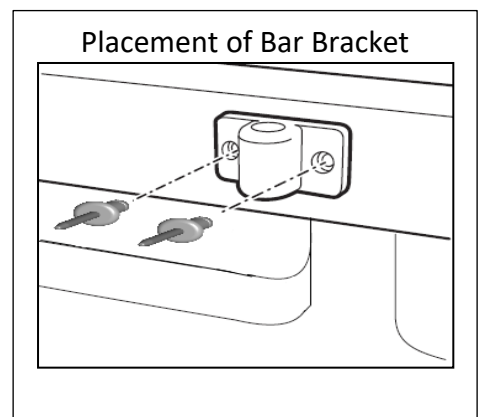

❖ Repeat Those Instructions For The Other Side.

### Step 3: Attach Tailgate Rail

- (a) Measure and mark the centre of rail and tailgate, to 325mm and 650mm from the centre of the rail, 30mm from the bottom edge.

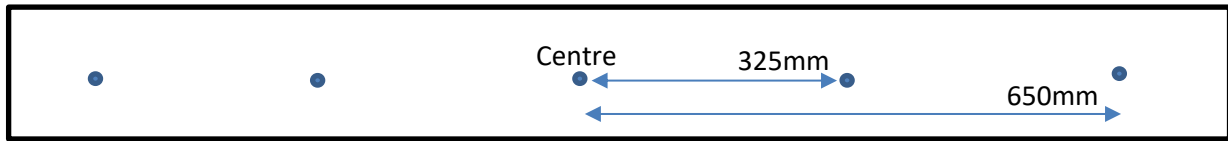

- (b) Position the aluminium in the centre of the tailgate, so that it is sitting square with the top surface of the tailgate.
- (c) Drill through each of the holes in the Aluminium rail into the tailgate.
- (d) Rivet the tailgate rail to the tailgate to complete the attachment.

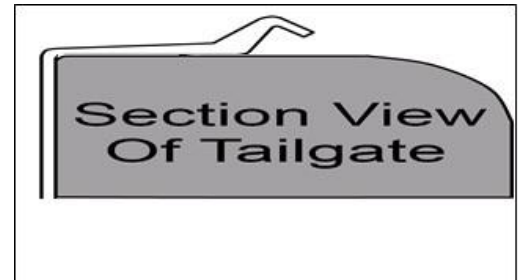

### Step 4: Fit Support Bar

- (a) Insert solid bar pieces into either end of hollow tube.
- (b) Place the bar into the Bar Brackets and centre the hollow tube.
- (c) Adjust the hollow tube so the holes are facing to the ground (this prevents the grub screws rubbing against the tonneau).
- (d) Tighten the grub screws to secure the hollow tube into place.

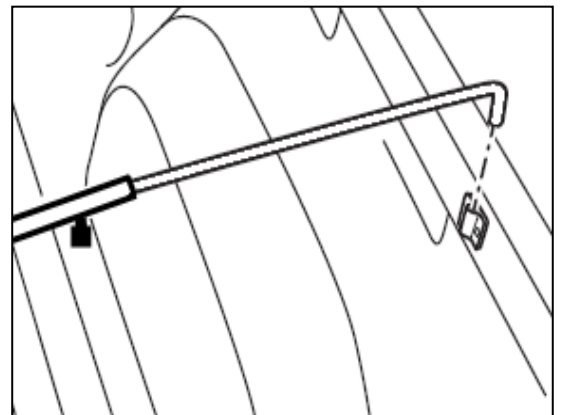

**NOTE: Do not over tighten screws as you may damage the threads.**

### Step 5: Fit Cover

- (a) Fit the front of the Tonneau Cover to the front of the Ute tub placing the Plastic Retainer (Fitted on the Tonneau Cover) on to the Metal Lip on the Body, between the cabin and the Ute Body (Behind rear windscreen).
- (b) Pull the cover under the sports bar and drape the cover across the tub.
- (c) Clip the side plastics under the aluminium rails to stretch the cover.

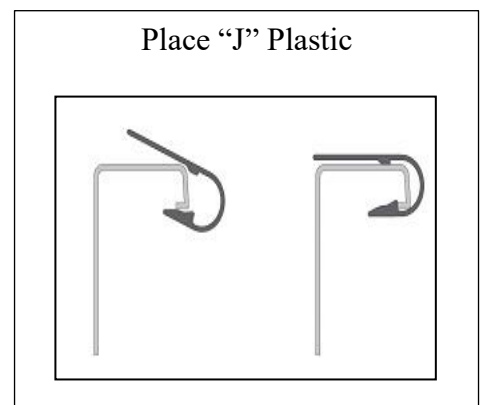

(d) To remove cover once fitted peel cover away from Aluminium clip in rail by peeling away from the edge of the plastic.

(e) **IMPORTANT:** Do not use cover corners to lift. Always use plastic edges.

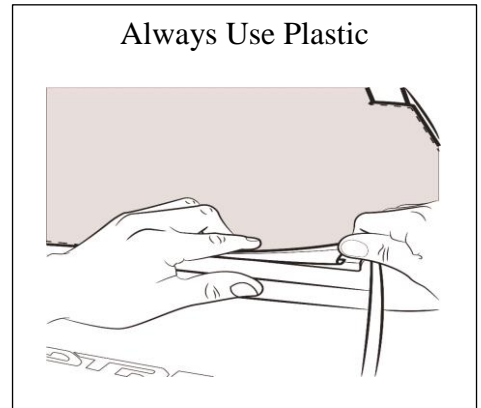

## How to Fit Internal Elastic Shock Cord

To be used for covering larger loads

- Tie a knot in one end of the shock cord.
- Pull shock cord through all plastic hooks.
- Feed the shock cord through loops on the cover.
- Tie a knot at the other end.
- Space the hooks as required.
- Use washers to tie off rope.

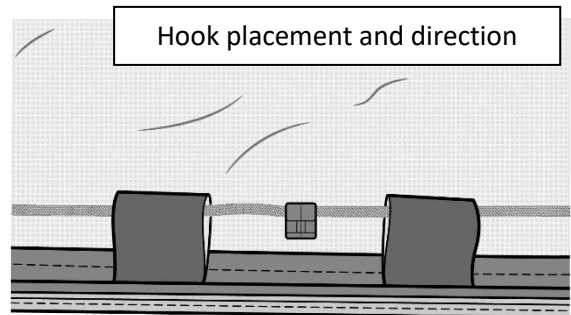
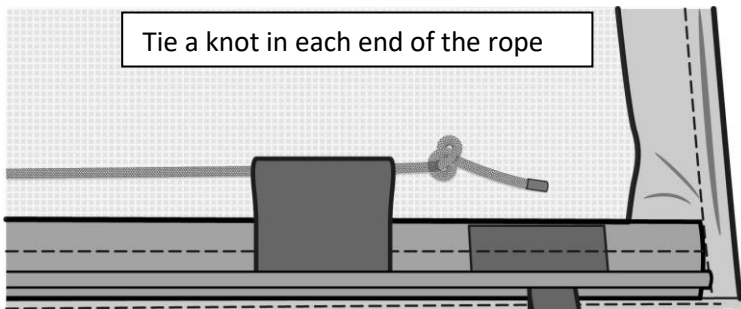
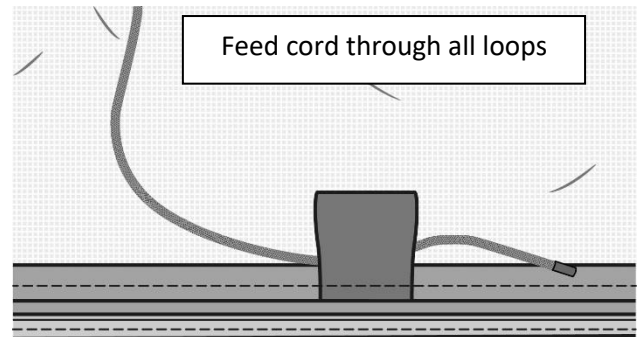

## How To Easily Attach & Detach Your Clip On Cover



No more ugly pull tabs, tearing covers, or needing Arnold-like strength with this method!

---

- Visit the following link: <http://bit.ly/AT-CLIP>
- Or simply scan the QR code. Open your camera app and point it here to see the video! → → →

