

# Tonneau Cover Fitting Instructions

## Holden Colorado Crew Cab with Headboard Clip On Tonneau

2012 – Current

Part number: ATC01261

<b>Package includes</b>	
1 x Tonneau Cover	2 x Bar Bracket
1 x Tailgate Rail (1370mm)	18 x Rivets
2 x Side Rails (1310mm)	1 x Support Bar
	1 x Fitting instructions

# 1. TONNEAU COVER FITTING

## **NOTE**

Read entire instructions prior to start.

## 1.1 BASIC TOOL REQUIRED

Drill, 4.5mm Drill Bit, Rivet Gun, Marking Pencil / Pen

## 1.2 TONNEAU COVER INSTALLATION PROCEDURE

1. Locate the Side Extrusion (1310mm) hard up against the front edge of the tub with the notch to the rear.
2. Slide each the profile down keeping it square with the top of the tub.
3. From the front edge of the rail, measure and mark the following locations:
  - 50mm, 300mm, 620mm, 652.5mm, 910mm and 1160mm. 30mm from the bottom edge.

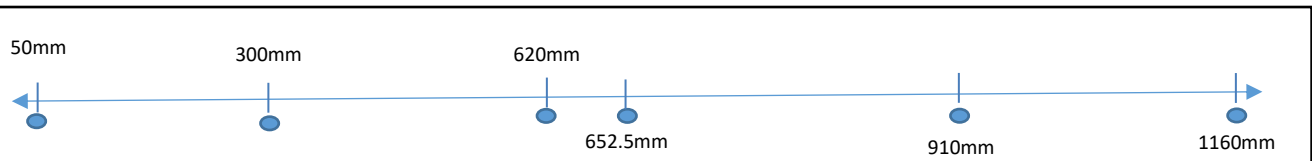

4. Drill through those locations into tub, using 4.5 drill bit. Then rivet into 50mm, 300mm, 910mm and 1160mm.
5. Attach the bar bracket by placing a 4mm rivet through each hole of the bracket and into the centre holes in the rail. Rivet into the remaining holes (620mm and 625.5mm).

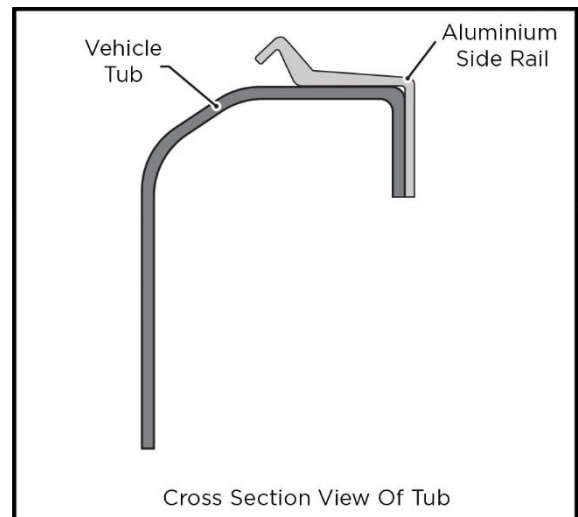

❖ **Repeat Those Instruction For The Other Side.**

6. To fit the tailgate profile, measure and mark the centre of the tailgate and the aluminium profile.
7. Align the two centre marks keeping the taped surface square with the top edge of the tailgate.
8. Measure and mark on 315mm and 630mm from the centre of the rail to both end, 30mm from the bottom edge.

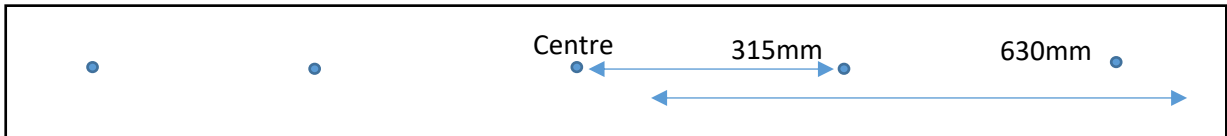

9. With a 4.5mm drill bit, drill and rivet each of the 5 marked holes.

10. Refer to Multi-Fit Support Bar Instructions located in section 2.

11. To attach the cover, fit the 3 plastic retainers at front of the Tonneau Cover to the Headboard of the Ute.

12. Clip the plastic onto the tailgate extrusion using the pull loops in the corners to help stretch the cover.

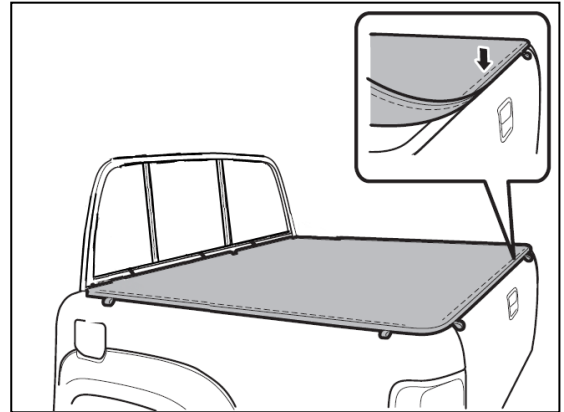

13. Clip the driver's side of the cover onto the driver's side extrusion then attach the passenger side of the cover using the pull loops in the corners to help stretch the cover.

## 2. HOW TO FIT INTERNAL ELASTIC SHOCK CORD

- Tie a knot in one end of shock cord.
- Pull shock cord through all plastic hooks.
- Feed the shock cord through loops on the cover.
- Tie a knot at the other end
- Space the hooks as required
- Use washers to tie off rope

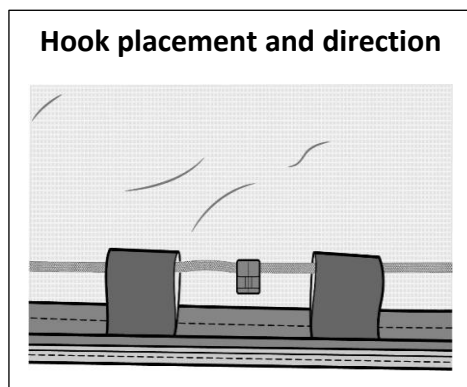
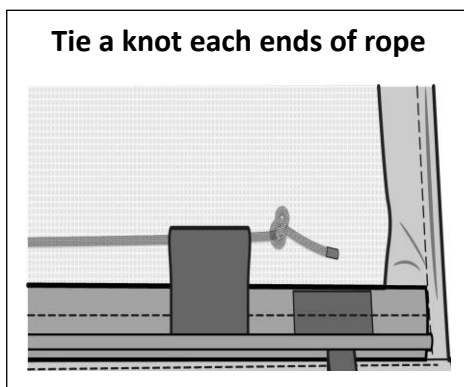
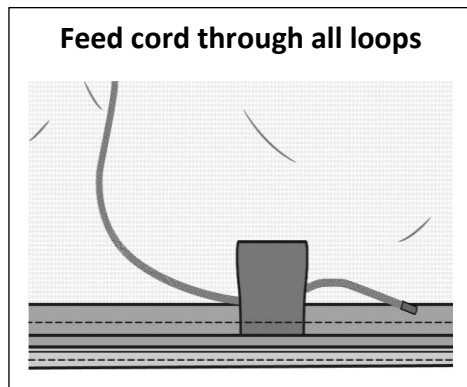

### Using Internal Elastic Shock Cord:

The plastic clips on the internal shock cord can be hooked into the aluminium extrusions so that the cover can still be secured with larger loads in the tub.

### 3. MULTI-FIT SUPPORT BAR

The Support Bar is designed to fit almost all Utes on the Market, from Subaru, Brumby's, to Cab Chassis and aluminium trays.

#### 3.1 MULTI-FIT SUPPORT BAR CONTENTS

- 1 x hollow bar centrepiece
- 2 x grub screws
- 2 x solid bar end piece

#### 3.2 FITTING MULTI-FIT BAR

1. Insert solid bar pieces into either end of hollow tube. Adjust bar so it fits between bar bracket holders with the holes facing to the ground (so the grub screws don't rub against the tonneau), as shown above and then with a white pencil make a mark through the small holes of the hollow bar onto the solid ends. This is where you will drill a hole to the depth of about 1-2mm (do not go any further)
2. Join the pieces back together and screw grub screws through the hollow bar into the holes that you drilled. **Make sure you do not over tighten the grub screws.** Refit the bar. You may kink the bar in the middle to give it some extra height to assist with water runoff.

**You can adjust your tonneau, to make it tighter or looser, by simply raising or lowering the height of your tonneau support bar**