

Tonneau Cover Fitting Instructions

Ford PX Ranger Super Cab

Oct 2012 - Current

Part number: ATC01243

Package includes

<input type="checkbox"/> 1 x Tonneau Cover	<input type="checkbox"/> 2 Side Rail (1700mm)
<input type="checkbox"/> 1 x Rope Track (1494mm Long)	<input type="checkbox"/> 2 x Support Bar (300516)
<input type="checkbox"/> 4 x Bar Bracket	<input type="checkbox"/> 1 x Tailgate Rail (1380mm)
<input type="checkbox"/> 31 x 4 mm Rivet	<input type="checkbox"/> 1 x Fitting instructions
<input type="checkbox"/> 1x Shock Cord	<input type="checkbox"/> 2 x M8 Washers
<input type="checkbox"/> 4 x Rope Hooks	
<input type="checkbox"/> 1x Metal Bracket	

1. TONNEAU COVER FITTING

1.1 TONNEAU COVER INSTALLATION PROCEDURE

1. Attach the side aluminium rails (1700mm Long). Keeping the aluminium profile square with the top of the tub and the vertical face of the aluminium square with the inside edge of the tub. From the front edge of the rail, measure and mark the following locations:
 - 50mm, 325mm, 595mm, 627.5mm, 910mm, 1195mm, 1227.5mm, 1440mm and 1650mm.

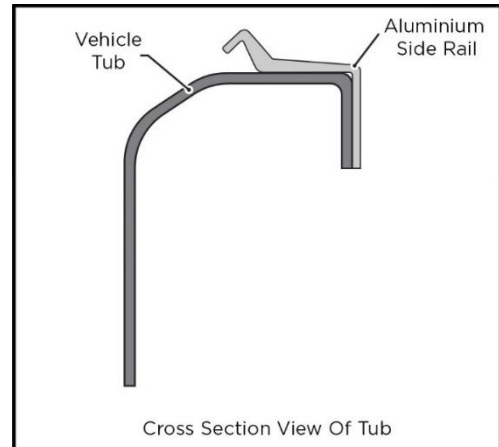

Drill through those locations into tub, using 4.5 drill bit. Then apply rust inhibitor and rivet into 50mm, 325mm, 910mm, 1440mm and 1650mm.

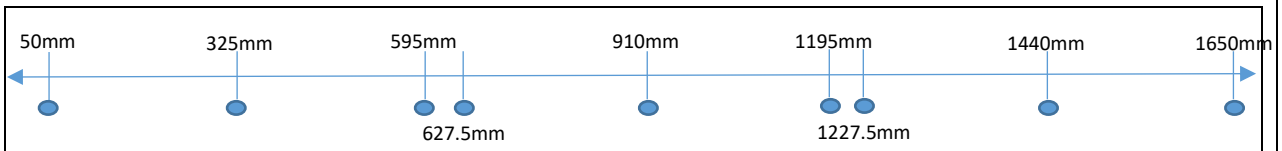
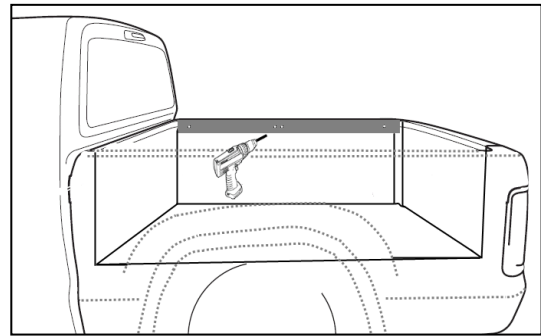

2. Attach the bar bracket by placing a 4mm rivet through each hole of the bracket and into the holes in the centre of the rail.

Apply rust inhibitor and rivet the rest of the holes (595mm and 627.5mm) and (1195mm and 1227.5) to complete attachment of side rails.

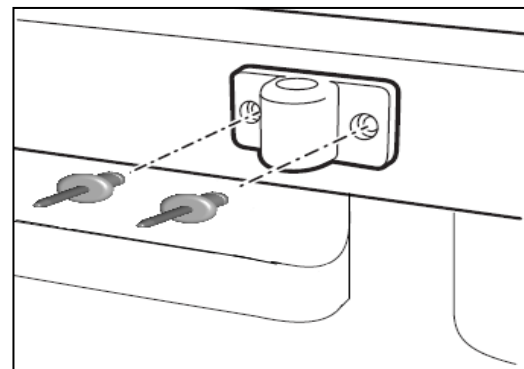

❖ Repeat steps 5 and 6 for the opposite side of vehicle.

3. Attach the tailgate aluminium rail (1380mm Long).

Position the aluminium in the centre of the tailgate, so that it is sitting square with the top surface of the tailgate.

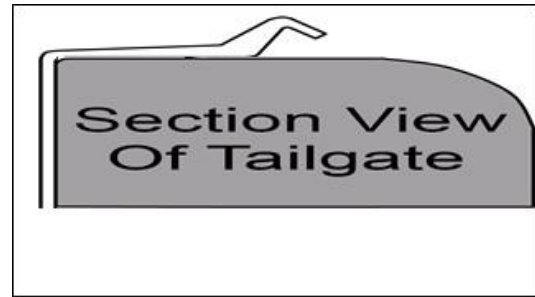

Measure and mark the centre, to both 325mm and 650mm from the centre of the rail, 30mm from the bottom edge.

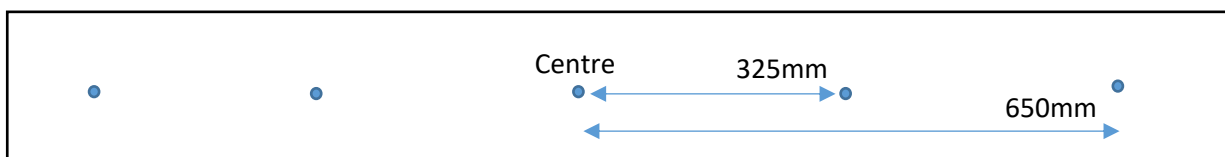

4. Drill through each of the holes in the Aluminium rail into the tailgate. Apply rust inhibitor and rivet the tailgate rail to the tailgate to complete the attachment.

5. Fit the adjustable support bar. Insert solid bar pieces into either end of hollow tube. Place the bar into the Bar Brackets and centre the hollow tube.

Adjust the hollow tube so the holes are facing the ground (this prevents the grub screws rubbing against the tonneau). Tighten the grub screws to secure the hollow tube into place.

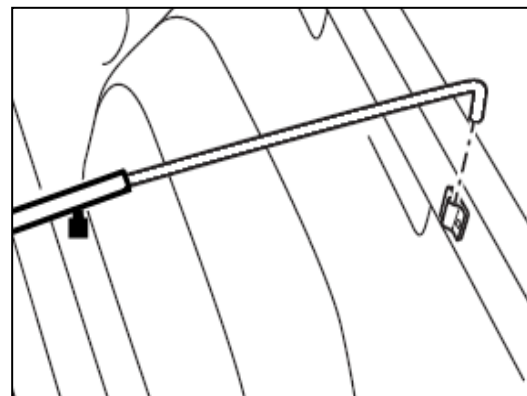

Fit Cover

- a) Fit the front of the Tonneau Cover to the front of the Ute tub placing the Plastic Retainer (Fitted on the Tonneau Cover) on to the Metal Lip on the Body, between the cabin and the Ute Body. (Behind rear windscreen).
- b) Pull the cover under the sports bar and drape the cover across the tub.
- c) Clip the side plastics under the aluminium rails to stretch the cover.

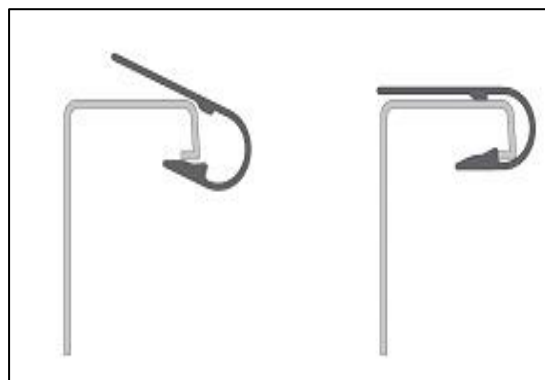

You can adjust your tonneau, to make it tighter or looser, by simply raising or lowering the height of your tonneau support bar.

To Remove Cover Correctly

To remove cover once fitted peel cover away from aluminium clip in rail by peeling away from the edge of the plastic.

IMPORTANT: Do not use cover corners to lift. Always use plastic edges.

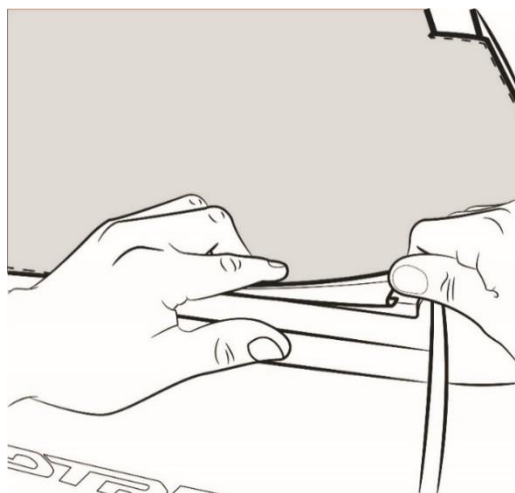

Using Internal Elastic Shock Cord:

The plastic clips on the internal shock cord can be hooked into the aluminium rails so that the cover can still be secured with larger loads in the tub.

NOTE: You can adjust your tonneau, to make it tighter or looser, by simply raising or lowering the height of your tonneau support bar.

Tonneau Cover Tethering System

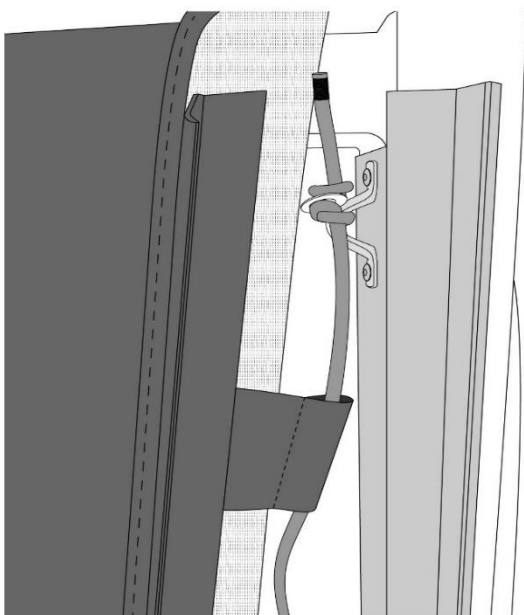

- Rivet the extra Metal Bracket to the Front Driver Side Rail.
- Untie the end of the rope of the Cover and loop it through the Metal Bracket.
- Rethread the Washer and tie the end of the rope into a knot.

How To Fit Internal Elastic shock Cord

To Be Used For Covering Larger Loads

- Tie a knot in one end of the shock cord.
- Pull shock cord through all plastic hooks.
- Feed the shock cord through loops on the cover.
- Tie a knot at the other end.
- Space the hooks as required.
- Use washers to tie off rope.

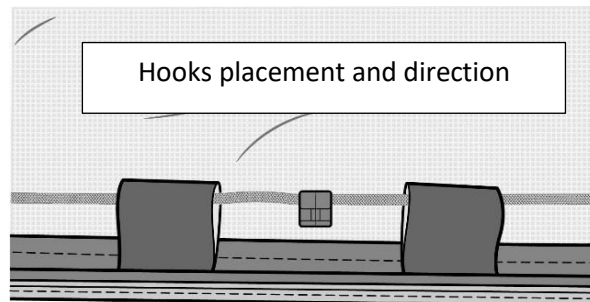
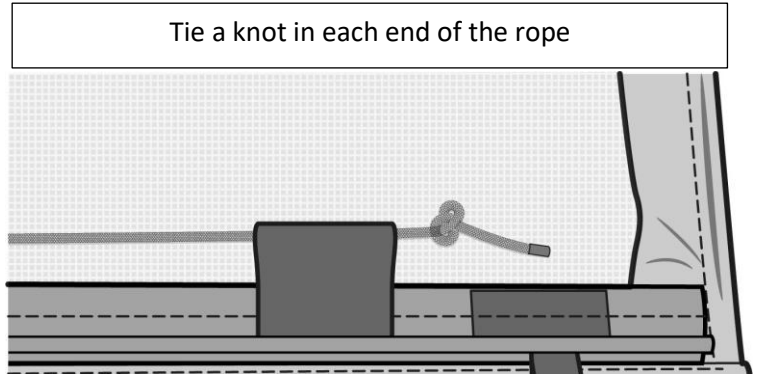
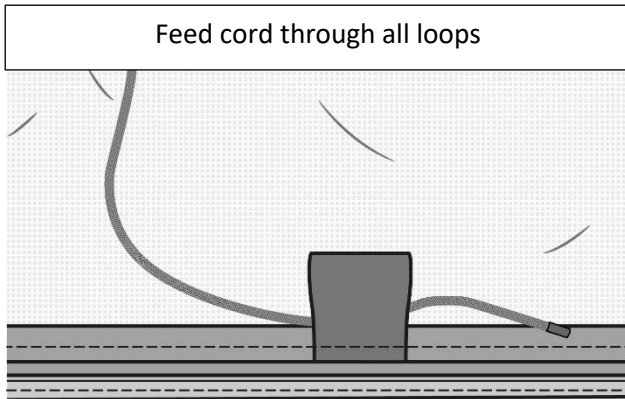

How To Easily Attach & Detach Your Clip On Cover



No more ugly pull tabs, tearing covers, or needing Arnold-like strength with this method!

- Visit the following link: <http://bit.ly/AT-CLIP>
- Or simply scan the QR code. Open your camera app and point it here to see the video! → → →

