

# Tonneau Cover Fitting Instructions

## Toyota Hilux Dual Cab With Factory Sports Bars

October 2015 Current

Part number: ATC01226

<b>Package includes</b>	
1 x Tonneau Cover	2 x Front Side Rail (380mm)
2 x Bar Bracket	2 x Back Side Rail (680mm)
18 x 4 mm Rivet	1 x Tailgate Rail (1315mm)
1 x Support Bar	2 x M8 Washers
1 x Shock cord	4 x Rope Hooks
1 x Fitting instructions	

## Step 1: Attach Front Side Rails

- (a) Attach the Front side Aluminium Rails (380mm Long) Centre the rail between the sports bars. Ensure the aluminium is square with the top of the tub and the notch must be at the front.
- (b) Measure and mark a spot 50mm in from each end and 30mm up from the bottom edge of the rail. Drill through these locations into the tub using a 4.5mm drill bit. Then rivet into place.

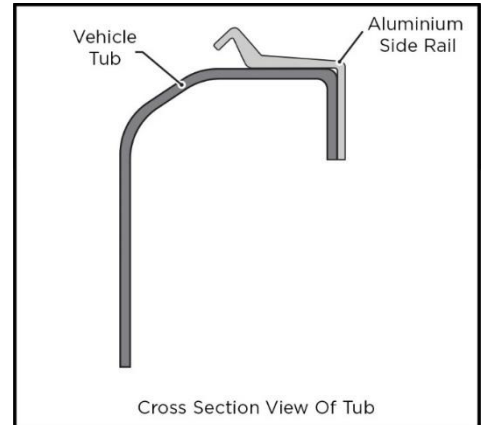

## Step 2: Attach Rear Side Rails

- (a) Attach the Rear side Aluminium Rails (680mm Long). Position the rail behind the sports bars. Ensure the aluminium is square with the top of the tub.
- (b) From the front edge of the rail, 30mm from the bottom edge, measure and mark the following locations:
  - 90mm, 123.5mm, 375mm and 630mm

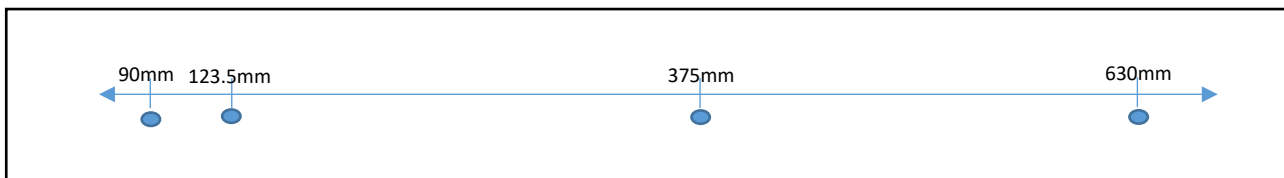
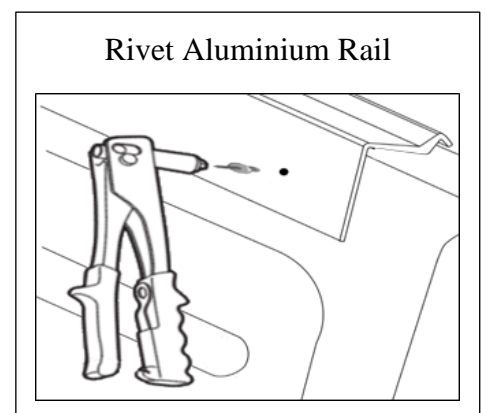

- (c) Drill through these locations into the tub using a 4.5mm drill bit. Attach the bar bracket by placing a 4mm rivet through each hole of the bracket and into the centre holes in the rail.
- (d) Rivet remaining holes (90mm and 123.5mm).

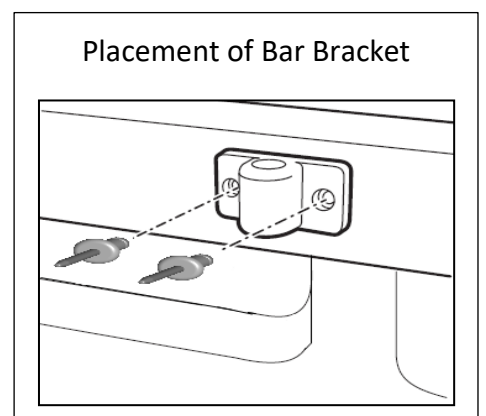

❖ Repeat step 1 and 2 for the other side.

### Step 3: Attach Tailgate Rail

- (a) Measure and mark the centre, and 302mm and 605mm from the centre of the rail, 30mm from the bottom edge.

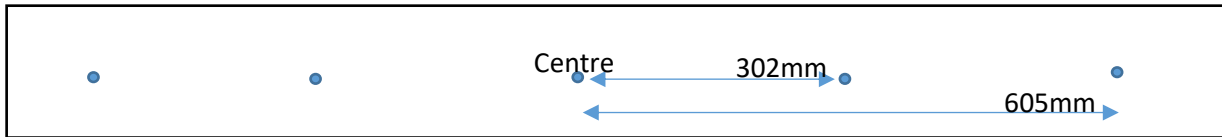

- (a) Position the aluminium in the centre of the tailgate, so that it is sitting square with the top surface of the tailgate.
- (b) Drill through each of the holes in the Aluminium rail into the tailgate.
- (c) Rivet the tailgate rail to the tailgate to complete the attachment.

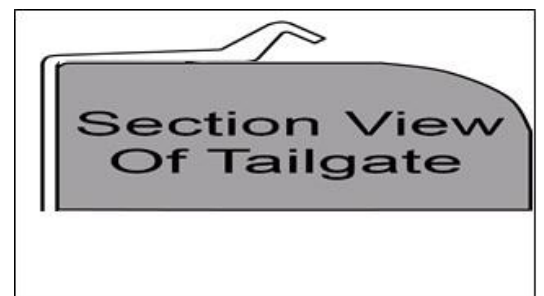

### Step 4: Fit Support Bar

- (a) Insert solid bar pieces into either end of hollow tube. Place the bar into the Bar Brackets and centre the hollow tube.
- (b) Adjust the hollow tube so the holes are facing to the ground (this prevents the grub screws rubbing against the tonneau). Tighten the grub screws to secure the hollow tube into place.

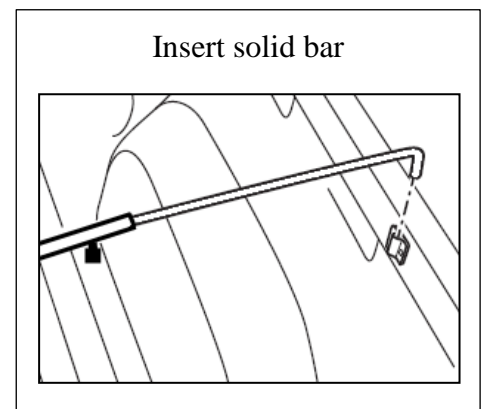

### Step 5: Fit Cover

- (a) Fit the front of the Tonneau Cover to the front of the Ute tub placing the Plastic Retainer (Fitted on the Tonneau Cover) on to the Metal Lip on the Body, between the cabin and the Ute Body. (Behind rear windscreen).
- (b) Clip the plastic onto the tailgate rail.

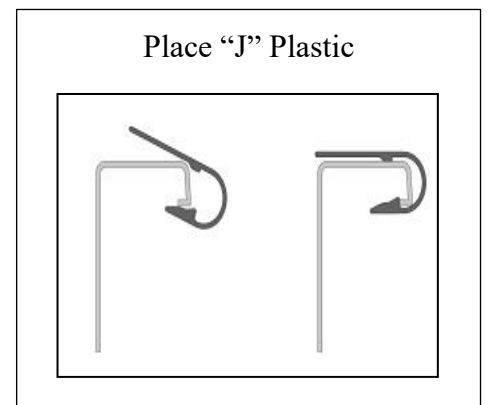

(c) Clip the driver's side of the cover onto the driver's side rail then attach the passenger side of the cover.

(d) To remove cover once fitted peel cover away from Aluminium clip in rail by peeling away from the edge of the plastic.

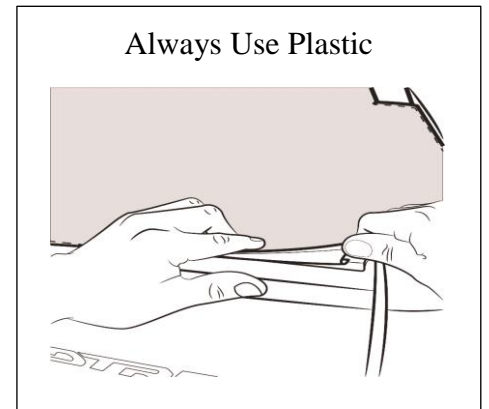

**IMPORTANT:** Do not use cover corners to lift. Always use plastic edges.

You can adjust your tonneau, to make it tighter or looser, by simply raising or lowering the height of your tonneau support bar.

## How To Fit Internal Elastic shock Cord

### To Be Used For Covering Larger Loads

- Tie a knot in one end of the shock cord.
- Pull shock cord through all plastic hooks.
- Feed the shock cord through loops on the cover.
- Tie a knot at the other end.
- Space the hooks as required.
- Use washers to tie off rope.

