

Tonneau Cover Fitting Instructions

Nissan Navara Dual Cab

NP300 / D23

Without Sports Bars

April 2015 Current

Part number: ATC01224

Package includes	
1 x Tonneau Cover	2 x Bar Bracket
2 x Side Rail (1390mm)	20 x 4 mm Rivet
1 x Tailgate Rail (1340mm)	1 x Shock cord
1x Fitting Instruction	4 x Rope Hooks
1 x Support Bar	2 x Washer
	1 x Metal Bracket

Please note before Fitment:

- Read all instructions prior to fitting the Tonneau cover.
- Check that the fitting kit is complete before beginning the installation.
- If replacing a previously fitted Aussie Tonneaus Cover the front rope track (if fitted) must be removed from the vehicle.
- If replacing any other cover all hardware must be replaced with hardware supplied.

Installation instructions.

Step 1. Attach the Side Rails (1390mm)

- (a) Position the Side Rail along the Driver's Side of the tub up against (Notch side must be at the back of the tub) pushing the Side Rail up against the front tub.
Keep the Side Rail square and flush with the top of the tub.
- (b) Mark the locations (**50mm, 425mm, 680mm, 712.5mm, 965mm and 1310mm**) onto the side rail with the Non-permanent marking pen.
- (c) Drill each of the marked locations through the aluminium and into the inside edge of the tub.
- (d) Then rivet all holes except 2 centre holes (leave for bar bracket)

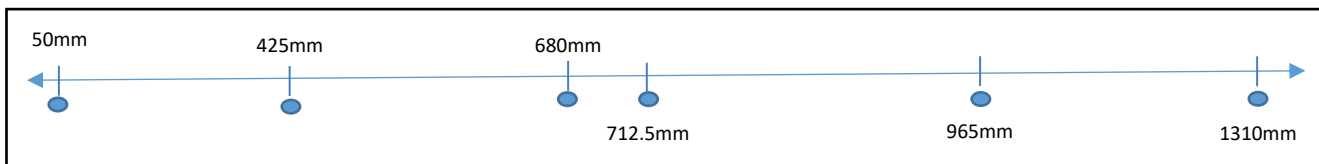
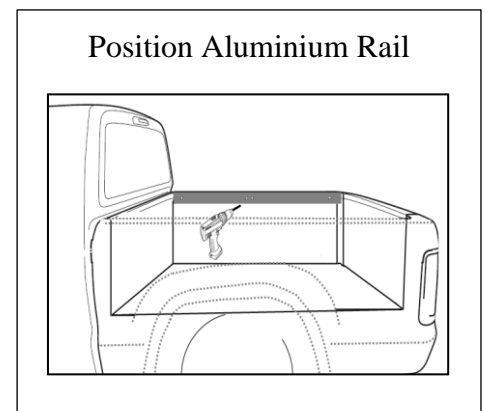
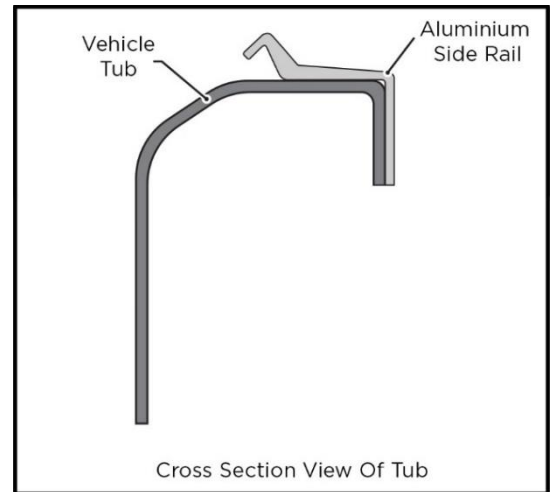

Step 2. Attach The Bar Bracket

Attach the bar bracket by placing a 4mm rivet through each hole of the bracket and into the centre holes in the rail. Rivet into place.

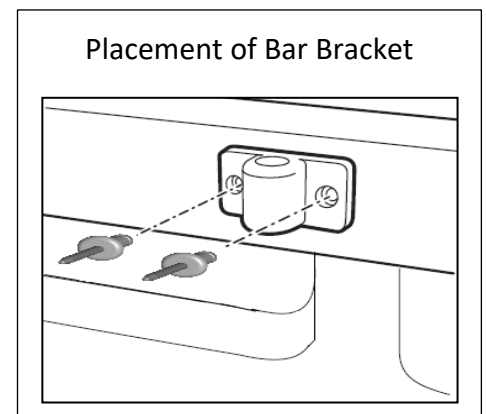

➤ Repeat steps 1 and 2 for the Passenger Side of vehicle.

Step 3. Attach the Tailgate

- (a) Centre the Tailgate Rail on the tailgate, keeping it square and flush with the top of the tailgate.
- (b) Measure and mark the centre, and **300mm** and **635mm** from the centre of the rail to both ends, **30mm** from the bottom edge.

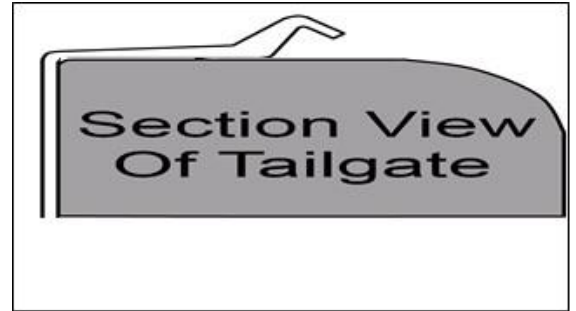

- (c) Drill through each of the holes in the aluminium rail into the tailgate.

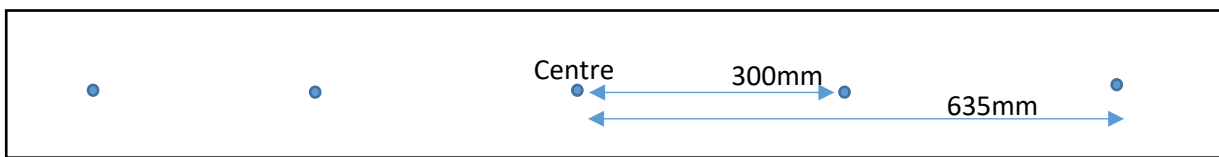

- (d) Apply rust inhibitor and rivet the Tailgate Rail to the tailgate to complete the attachment.

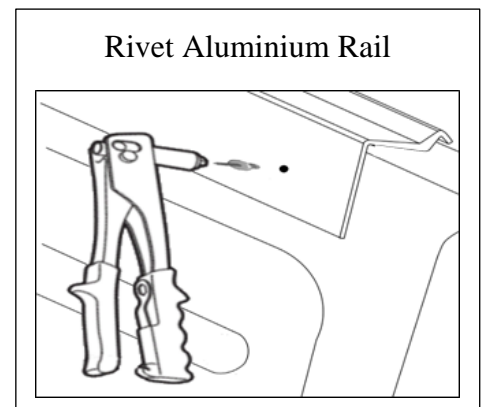

Step 4. Fit Support Bar

- (a) Insert solid bar pieces into either end of hollow tube. Place the bar into the Bar Brackets and centre the hollow tube.
- (b) Adjust the hollow tube so the holes are facing to the ground (this prevents the grub screws rubbing against the tonneau).
- (c) Tighten the grub screws to secure the hollow tube into place.

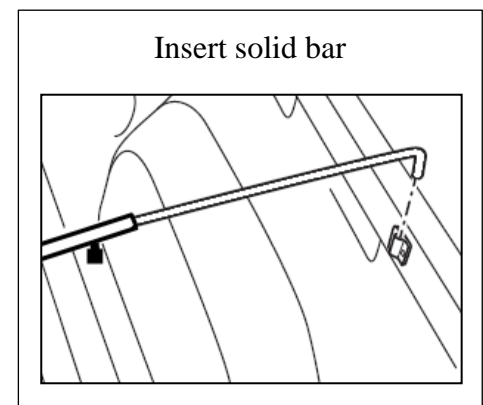

Do not over tighten screws as you may damage the threads.

Step 5. Fit The Tonneau Cover

- (a) Fit the front of the Tonneau Cover to the front of the Ute tub placing the Plastic Retainer (Fitted on the Tonneau Cover) on to the Metal Lip on the Body, between the cabin and the Ute Body (Behind rear windscreen) .

Note: Remove the rubber dust seal from the Ute Body before fitting the cover.

- (b) Clip the plastic onto the tailgate rail.
(c) Clip the driver's side of the cover onto the driver's side rail then attach the passenger side of the cover.
(d) To remove cover once fitted peel cover away from Aluminium clip in rail by peeling away from the edge of the plastic.

- (e) **IMPORTANT:** Do not use cover corners to lift. Always use plastic edges.

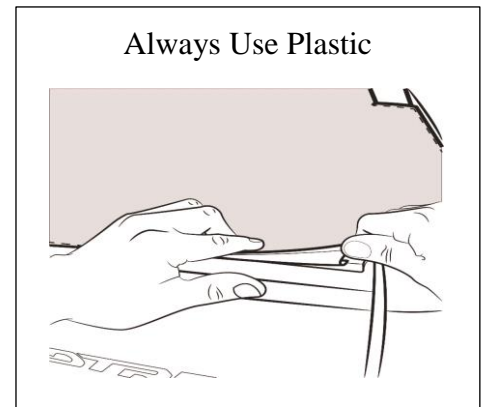

You can adjust your tonneau, to make it tighter or looser, by simply raising or lowering the height of your tonneau support bar.

How to Fit Internal Elastic Shock Cord

To be used for covering larger loads

- Tie a knot in one end of the shock cord.
- Pull shock cord through all plastic hooks.
- Feed the shock cord through loops on the cover.
- Tie a knot at the other end.
- Space the hooks as required.
- Use washers to tie off rope.

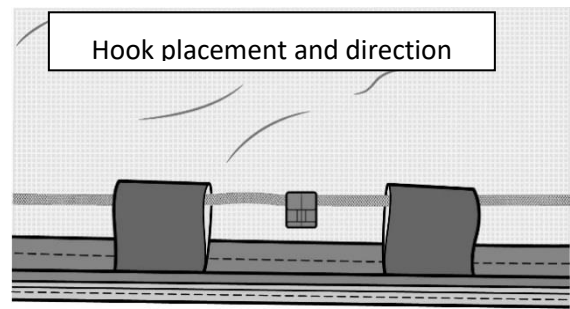
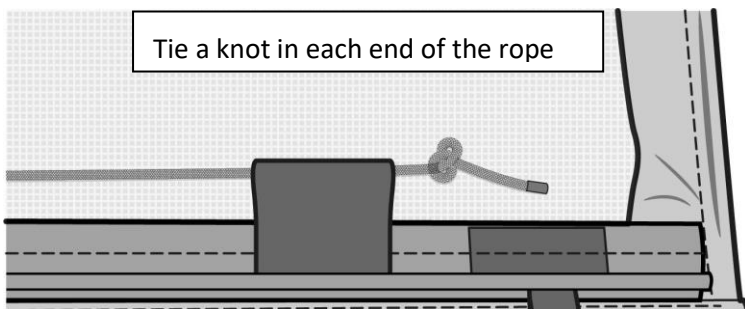
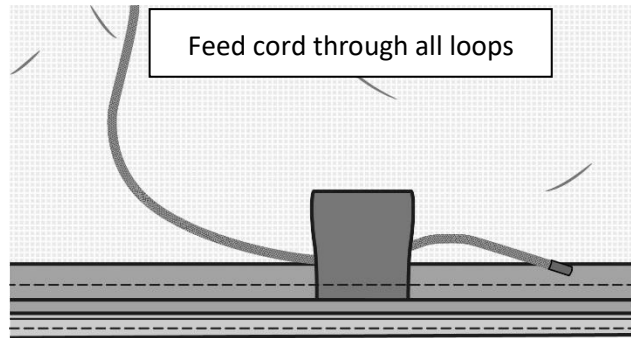

Tonneau Cover Tethering System



- Rivet the extra Metal Bracket to the Front Driver Side Rail.
- Untie the end of the rope of the Cover and loop it through the Metal Bracket.
- Rethread the Washer and tie the end of the rope into a knot.