

Isuzu D-Max

Clip on Tonneau Cover

2012 – 2020

Fitting Instruction
Part No. ATC01219

Description	QTY	Note
Tonneau Cover		
Side Rail	2	1400mm Long ea.
Shock Cord and Rope Hooks	1&5	
M8 Washers	2	
Tailgate Rail	1	1370mm Long
Support Bar	1	
Bar Bracket	2	
4 mm Rivets	20	
Metal Bracket	1	
Fitting Instructions	1	

Tools Require;

Drill, 4mm Drill Bit, Silicone, Rivet Gun, Marker, Tape Measure.

1. Attach Side Aluminium Rail

To attach the side aluminium profiles:

- Locate the Side Rail (1400mm) hard up against the front edge of the tub with the notch to the rear with the aluminium square with the top of the tub.
- From the front edge of the rail, measure and mark the following locations:
 - 50mm, 380mm, 660mm, 692.5mm, 970mm and 1220mm.
- Drill through those locations into tub, using 4.5 drill bit. Then rivet into 50mm, 380mm, 970mm and 1220mm.

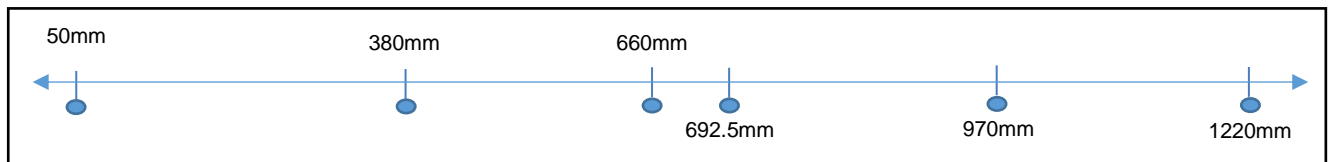
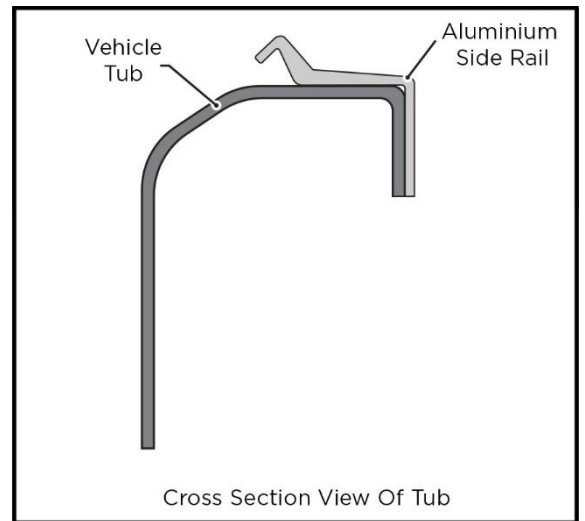

2. Attach Bar Bracket

- Attach the bar bracket by placing a 4mm rivet through each hole of the bracket and into the centre holes in the rail.
- Rivet remaining holes (660mm and 692.5mm).

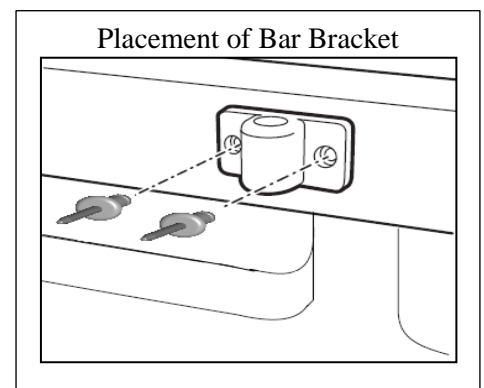

❖ Repeat Those Instructions For The Other Side.

3. Attach Tailgate Aluminium Rail

- Measure and mark the centre, and 325mm and 650mm from the centre of the rail, 30mm from the bottom edge.
- Position the aluminium in the centre of the tailgate, so that it is sitting square with the top surface of the tailgate.
- Drill through each of the holes in the aluminium rail into the tailgate. Rivet the tailgate rail to the tailgate to complete the attachment.

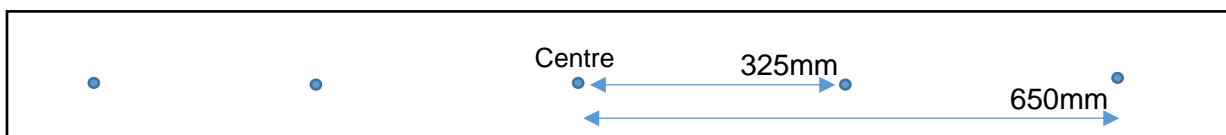
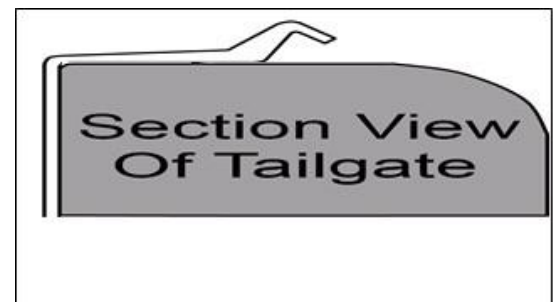

4. Fit The Support Bar

- Insert solid bar pieces into either end of hollow tube. Place the bar into the Bar Brackets and centre the hollow tube.
- Adjust the hollow tube so the holes are facing to the ground (this prevents the grub screws rubbing against the tonneau).
- Tighten the grub screws to secure the hollow tube into place.

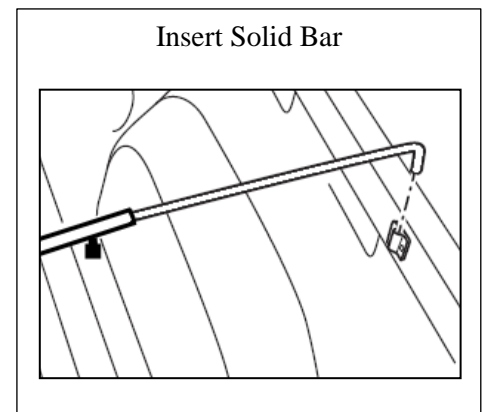

5. Attach The Cover

- Fit the front of the Tonneau Cover to the front of the Ute tub placing the Plastic Retainer (Fitted on the Tonneau Cover) on to the Metal Lip on the Body, between the cabin and the Ute Body. (Behind rear windscreen).
- Pull the cover under the sports bar and drape the cover across the tub.
- Clip the side plastics under the aluminium rails to stretch the cover.

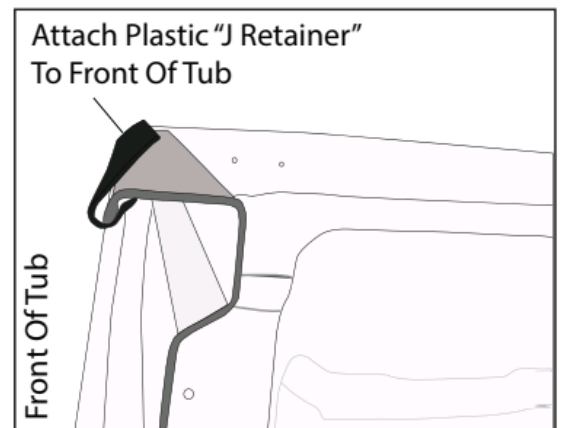

You can adjust your tonneau, to make it tighter or looser, by simply raising or lowering the height of your tonneau support bar.

How to Fit Internal Elastic Shock Cord

To be used for covering larger loads

- Tie a knot in one end of the shock cord.
- Pull shock cord through all plastic hooks.
- Feed the shock cord through loops on the cover.
- Tie a knot at the other end.
- Space the hooks as required.
- Use washers to tie off rope.

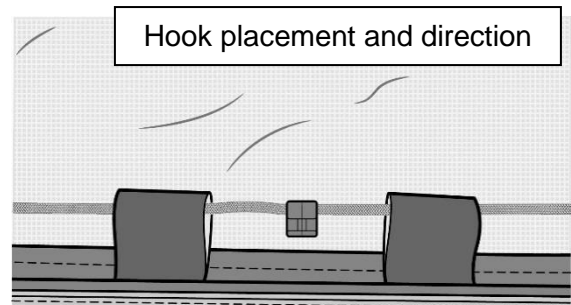
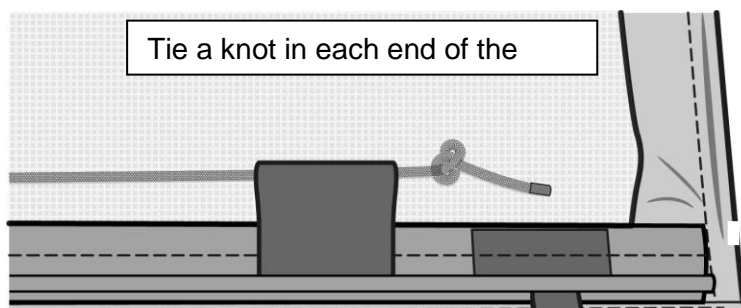
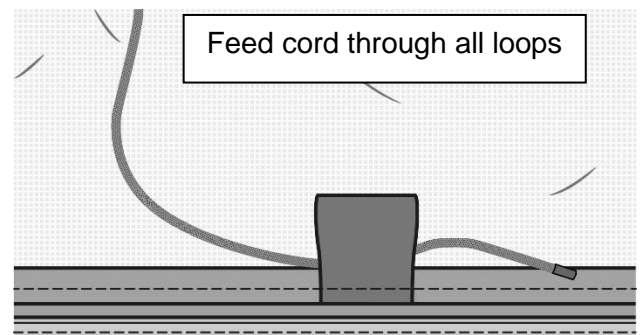

Tonneau Cover Tethering System



- **Rivet the extra Metal Bracket to the Front Driver Side Rail.**
- **Untie the end of the rope of the Cover and loop it through the Metal Bracket.**
- **Rethread the Washer and tie the end of the rope into a knot.**