

# **Fitting Instruction**

**Clip On Soft Tonneau Cover**

**Part No. ATC01147**

**Volkswagen Amarok Dual Cab  
With Factory Sport Bar Model**

# Installation Instruction

Please note before fitment:

- ❖ Read all instructions prior to fitting the Tonneau cover.
- ❖ Check that the fitting kit is complete before beginning the installation.
- ❖ If replacing any other cover all hardware must be replaced with hardware supplied.

## Safety Notes

- ❖ Ensure that appropriate Personal Protective Equipment is used.
- ❖ Always refer to vehicle's work shop manual when removing components.



## Parts Supplied

Tonneau Cover x 1	Ropetrack x 1	Tailgate Rail x 1	Rear Side Rail x 2	Front Side Rail x 2
Support Bar x 1	Support Barbrack x 2	Rivets x 26	Shock Cord x 1 Rope Hook x 4 Washer x 2	

## Tools Required

Drill	Pop Rivet Gun	Tape Measure	Pencil/ Marker	4mm Drill Bit

## 1. Importance Note

### Before Starting:

- ❖ Ensure the gap between the sports bar is between 664mm and 669mm. If the gap is outside of these measurements adjust the sports bars accordingly. *Figure 1*

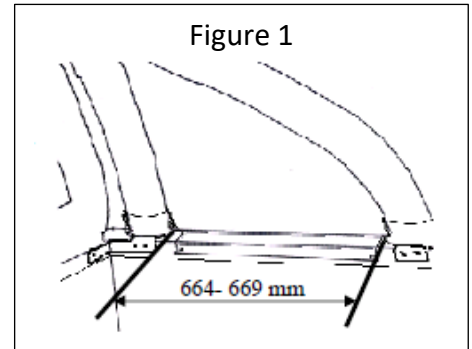

## 2. Attaching Ropetrack

- Rest the aluminium rope track on the top of the front edge of the Tub, with the 'C' channel facing the cabin. Centralise the rope track. *Figure 2*
- To get the correct space between the sports bar and rope track, place one bar bracket at each end of the rope track, between the sports bar and the back edge of the open section of the rope track. *Figure 3*
- Using a 4.5 mm drill bit, drill 5 holes evenly spaced through the aluminium rope track into the tub. The first hole at each end should be 100mm from the edge of the aluminium rope track. *Figure 4*
- Place a 4mm rivet in each hole as it is drilled, but do not rivet. Once all holes have been drilled, remove the rivets and ropetrack and clean any swarf.
- Apply rust inhibitor to the drilled holes in the tub and apply a bead of silicon to the ropetrack along the line of the holes.
- Place the ropetrack back into position and rivet ropetrack into place.

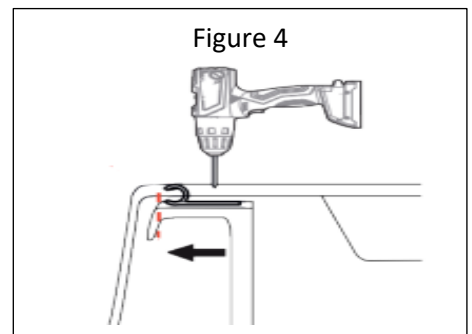
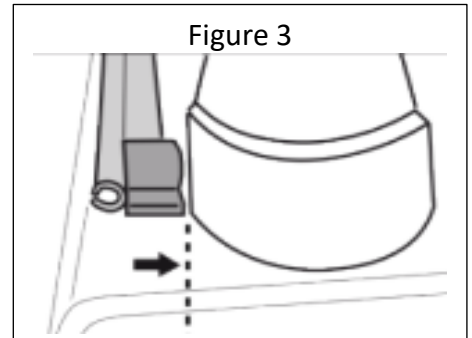
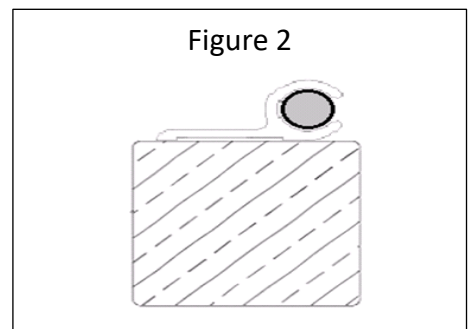

## 3. Attaching Front Side Rail

- Centre the rail between the sports bars. Ensure the aluminium is square and flush with the top of the tub. *Figure 5*
- From the front edge of the rail, 25mm from the bottom edge, measure and mark the following locations:
  - 50mm and 340mm, 600mm and 632mm

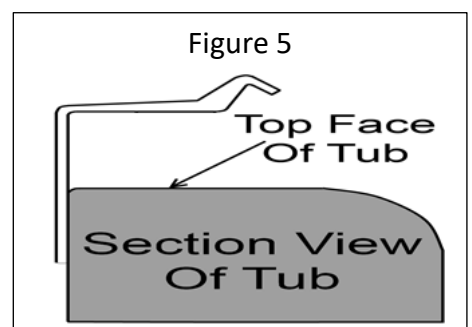
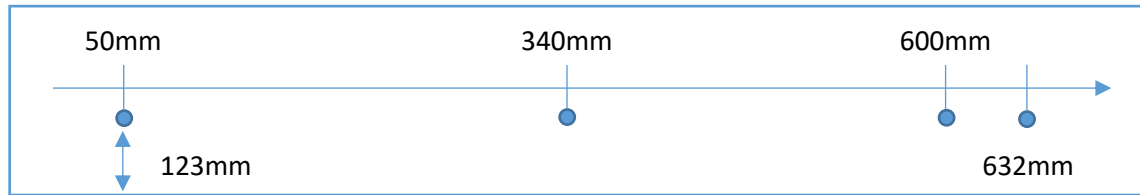
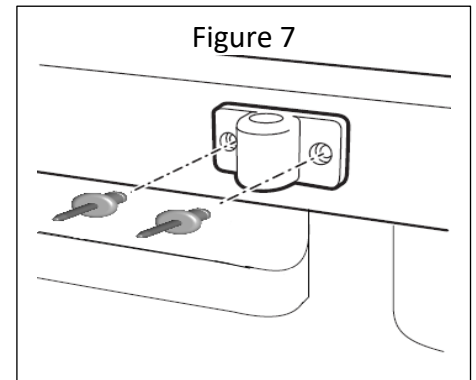

Figure 6



**IMPORTANT:** Keep **ALL Rails** flush with top of the Tub Walls and Tailgate while drilling.

- c. Drill each of the marked locations through the aluminium and into the inside edge of the tub. And rivet into 50mm and 340mm.
- d. Attach the bar bracket by placing a 4mm rivet through each hole of the bracket and rivet into the remaining holes, 600mm and 632mm. *Figure 7*
- e. Repeat those steps for the passenger's side.



#### 4. Attaching Rear Side Rail

- a. Place the rail 5mm behind the sports bars. Ensure the aluminium is square and flush with the top of the tub.
- b. Measure and mark a spot 50mm from each end and one in the middle, 25mm up from the bottom edge of the rail.
- c. Drill through these locations into the tub using a 4.5mm drill bit. Then rivet into place.

#### 5. Attaching Support Bar

- a. Undo grub screws on the hollow tube, then insert solid bar pieces into either end of hollow tube.
- b. Place the bar into the bar brackets (*see Figure 8*) and centre the hollow tube in the middle of the tub.
- c. Adjust the hollow tube so the screws are facing the tub floor. This prevents the grub screws rubbing against the tonneau cover.
- d. Tighten the grub screws to secure the hollow tube into place.

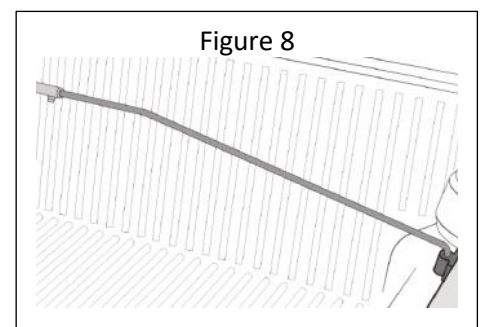

## 6. Attaching Tailgate

- Centre the aluminium rail on the tailgate and mark the tailgate for future reference (see Figure 9).

Figure 9

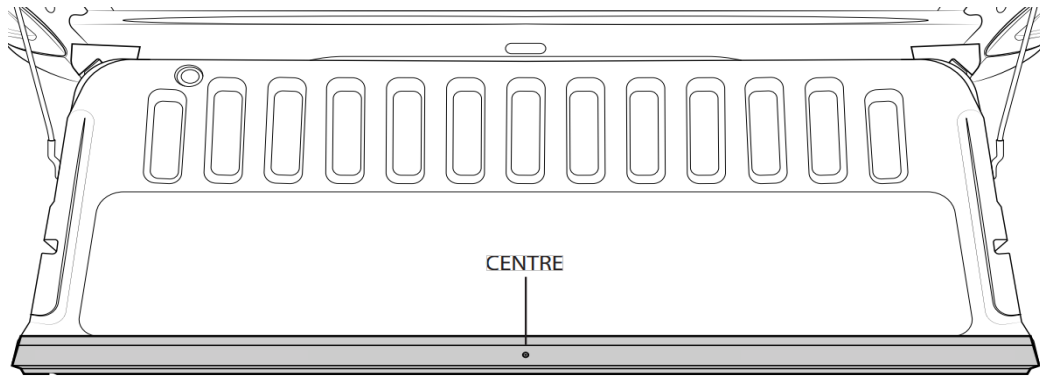

- Measure and mark all 5 points on the aluminium rail (see Figure 10) then drill out all 5 using a 4mm drill bit. We recommend drilling just the aluminium rail in this step.

Figure 10

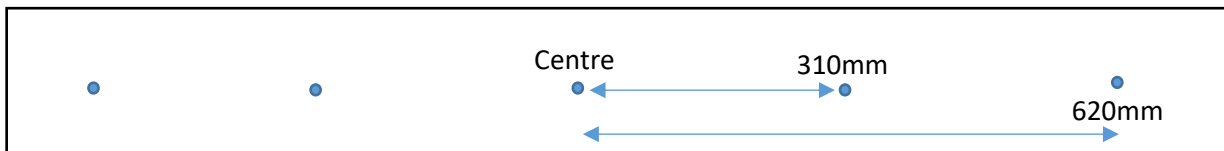

- With the aluminium now drilled, place it back onto the tailgate and re-centre, aligning with the previously measured centre mark.
- Drill through all 5 holes into the tailgate with the 4mm drill bit. And utilising the rivets provided, use your rivet gun to rivet the rail in at all 5 locations.

## 7. Fit The Tonneau Cover

- Slide the front rope of the tonneau cover into the ropetrack and centre the cover then drape the cover over the head board. *Figure 11*
- Clip the driver's side of the cover onto the driver's side rail then attach the passenger side of the cover using the plastic's edge in the corners to help stretch the cover.
- Clip the plastic onto the tailgate rail using the plastic's edge in the corners to help stretch the cover.
- To remove cover once fitted peel cover away from Aluminium clip in rail by peeling away from the edge of the plastic. *Figure 12*

Figure 11

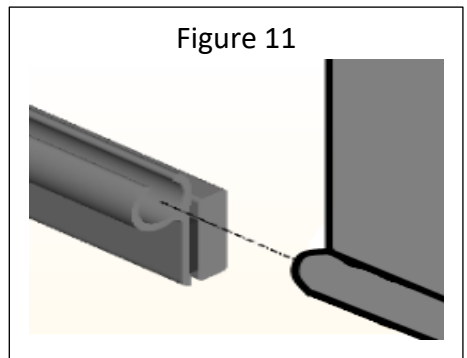
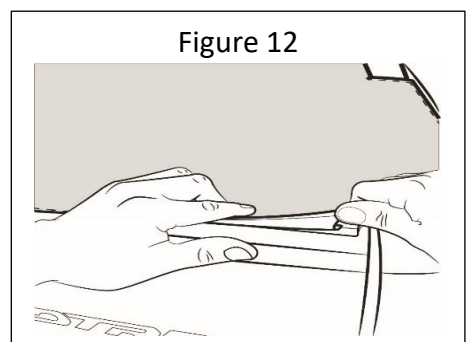

Figure 12



**IMPORTANT:** Do not use cover corners to lift. Always use plastic edges.

## 8. How To Fit Internal Shock Cord

- a. Tie a knot in one end of the shock cord

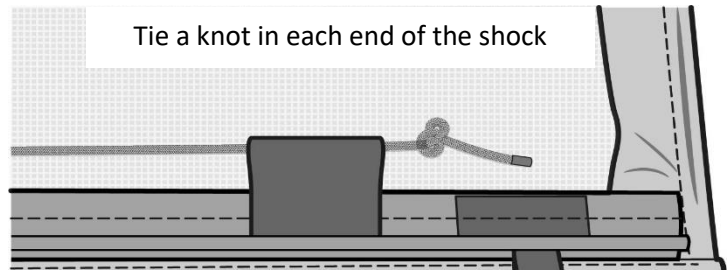

- b. Pull shock cord through all the plastic hooks.

- c. Feed the shock cord through the loops on the cover.

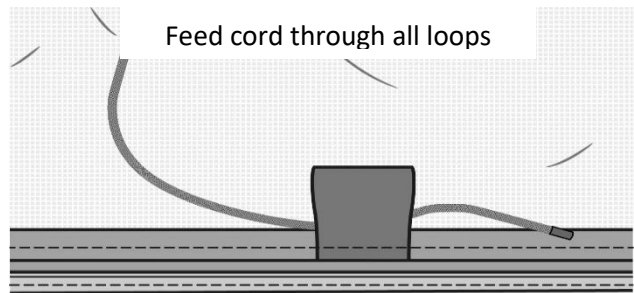

- d. Tie a knot at the other end.

- e. Space the hooks as required.

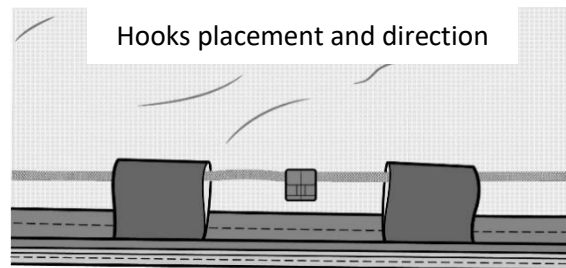

- f. Use washers to tie off the shock cord.

## 9. Warranty And Feedback

### Send Us A Photo Of Your Fitted Cover

Happy with how your tonneau turned out? Please email us a photo of your ute to: [sales@aussietonneaus.com.au](mailto:sales@aussietonneaus.com.au)



Please try and replicate this angle when taking a photo – thanks in advance for contributing!

### **How To Easily Attach & Detach Your Clip On Cover**



No more ugly pull tabs, tearing covers, or needing Arnold-like strength with this method!

- Visit the following link: <http://bit.ly/AT-CLIP>
- Or simply scan the QR code. Open your camera app and point it here to see the video! → → →

