

# **Fitting Instructions**

**Clip On Soft Tonneau  
Mitsubishi MN Triton  
Dual Cab with Headboard  
(No Sports Bars).  
Oct 2009 – Current**







**Part Number: ATC01109**

**Installation Time: 1 hour**

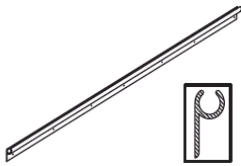
## Supplied Parts

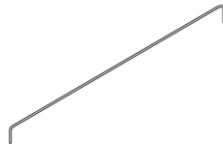
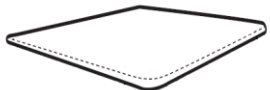
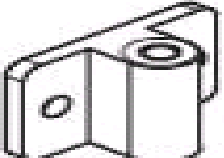

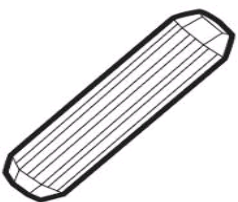

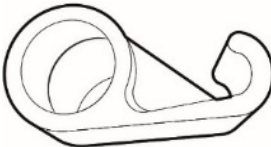
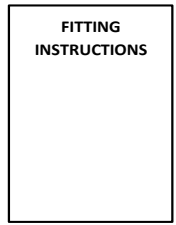
Please read all instruction prior to fitting the tonneau cover. Check that the fitting kit is complete before beginning the installation. Some items in fitting kit may not be required.

All fitting kits are weighed to ensure accurate quantities.

<b>Ropetrack x 1(1462mm)</b> 	<b>Tailgate Rail x 1(1330mm)</b> 	<b>Side Rail x 2(1440mm)</b> 	<b>Support Bar x 1</b> 
<b>Tonneau Cover x 1</b> 	<b>Bar Brackets x 2</b> 	<b>4mm Rivet x 23</b> 	<b>Dowel x 2</b> 
<b>Internal Shock Cord x 1</b> 	<b>Rope Hooks x 4</b> 	<b>Fitting Instruction x 1</b> 	

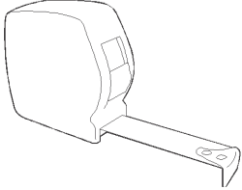
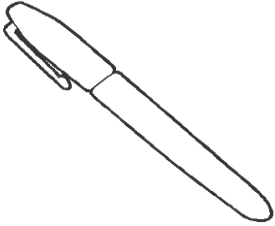
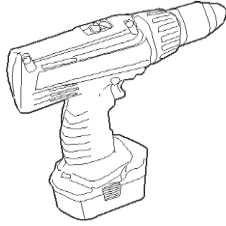
## Required tools.

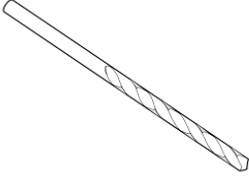
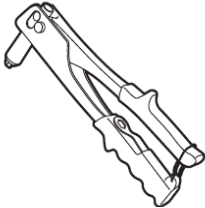
Ensure tools are in good working order prior to commencing installation.

<p><b>Tape Measure</b></p> 	<p><b>Non-permanent Marker</b></p> 	<p><b>Power Drill</b></p> 	<p><b>Safety Glasses</b></p> 
<p><b>Vacuum Cleaner</b></p> 	<p><b>4mm Drill Bit(New)</b></p> 	<p><b>Rivet Gun</b></p> 	<p><b>4mm Allen Key</b></p> 
<p><b>Clean Soft Rag</b></p> 			

# 1. INSTALLATION PROCEDURE

## 1. Ropetrack

- (a) Place the 2 pieces of dowel in the ends of the rope track.
- (b) Rest the aluminium rope track (Dowel pieces) on the side rails of Tub, ensure the flat side of the rope track is the surface positioned against the tub face.
- (c) Sit the flat side of the rope track on the top front edge of the tub with the 'C' channel facing forward.
- (d) Centralise the rope track.
- (e) The centre of the rope track will need to be curved (pushed) down 15mm to meet the top edge of the tub.
- (f) While pushing down on the rope track using a 4 mm drill bit, drill 5 holes evenly spaced through the aluminium rope track 8mm up from the bottom of the rope track into the front of tub.
- (g) Drill holes in the centre, 355mm each side of centre, and a holes 25mm from each end. The centre hole will need to be drilled on a downward angle to ensure it goes into the tub.
- (h) Place a 4mm rivet in each hole as it is drilled, but do not rivet.
- (i) Once all holes have been drilled, remove the rivets and rope track and clean any swarf.
- (j) Apply a bead of silicone to the flat face of the rope track/Shim (the edge that comes in contact with the edge of the tub) and place the rope track back into position and rivet rope track into place.

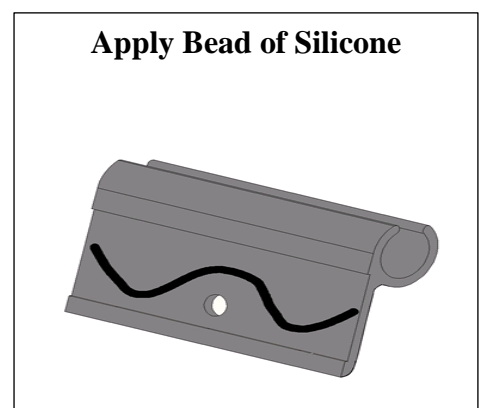
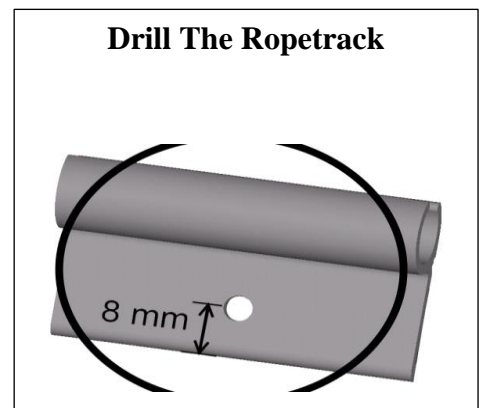
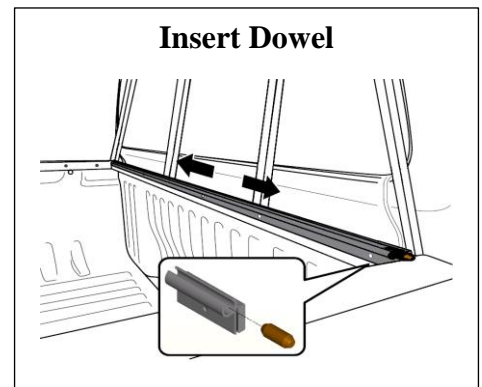

## 2. Attach Side Aluminium Rail

- (a) Attach the side Aluminium Rails (1440mm Long). Ensure the aluminium is square with the top of the tub.
- (b) From the front edge of the rail, measure and mark the following locations, 30mm up from bottom edge:
  - 50mm, 355mm, 683mm, 716mm, 1045mm and 1350mm.

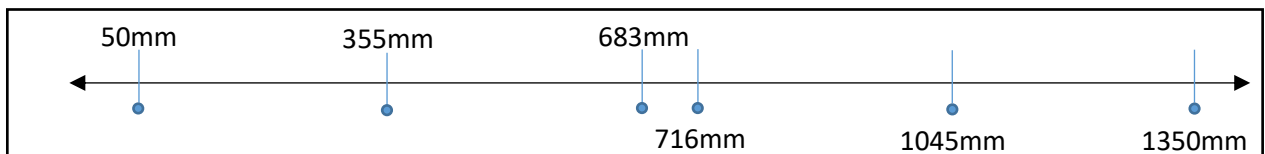
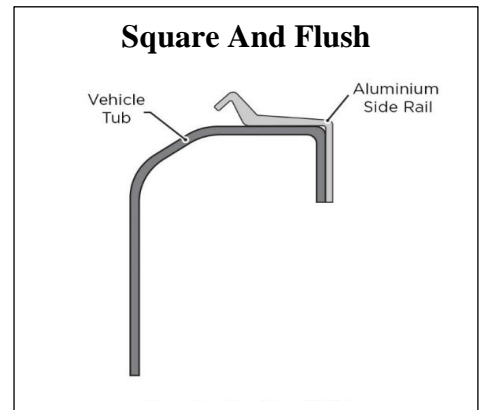

- (c) Drill through those locations into tub all locations and rivet into 50mm, 355mm, 1045mm and 1350mm.

## 3. Attach Bar Bracket

- (a) Attach the bar bracket by placing a 4mm rivet through each hole of the bracket and into the centre holes in the rail.
- (b) Rivet remaining holes. (683mm and 716mm).

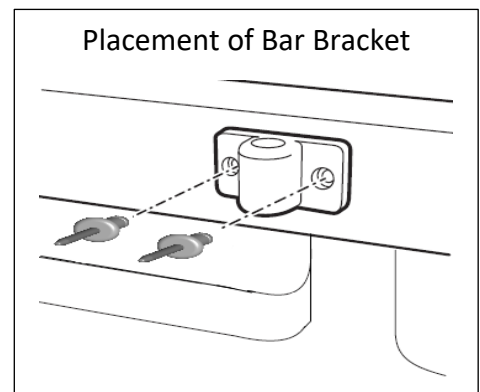

❖ Repeat Those Instruction (2) and (3) For The Other Side.

## 4. Attach The Tailgate Rail

- (a) Measure and mark the centre, and 300mm and 600mm from the centre of the rail, 30mm from the bottom edge.
- (b) Position the aluminium in the centre of the tailgate, so that it is sitting square with the top surface of the tailgate.

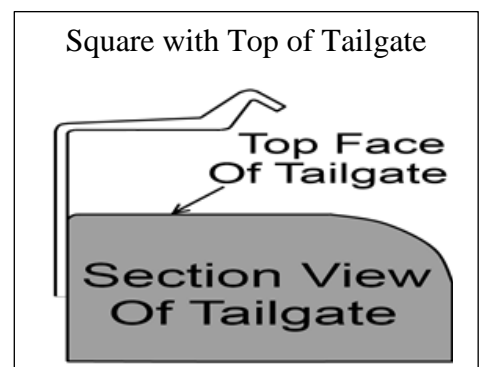

- (c) Drill through each of the holes in the aluminium rail into the tailgate. Rivet the tailgate rail to the tailgate to complete the attachment.

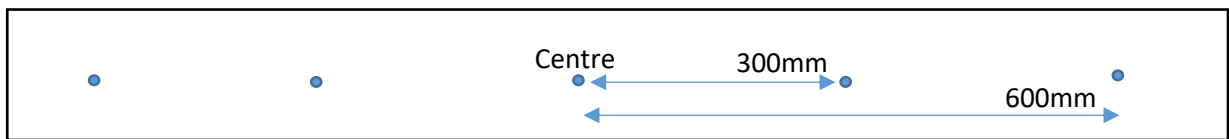

## 5. Fit Support Bar

- (a) Insert solid bar pieces into either end of hollow tube. Place the bar into the Bar Brackets and centre the hollow tube.
- (b) Adjust the hollow tube so the holes are facing to the ground (this prevents the grub screws rubbing against the tonneau). Tighten the grub screws to secure the hollow tube into place.

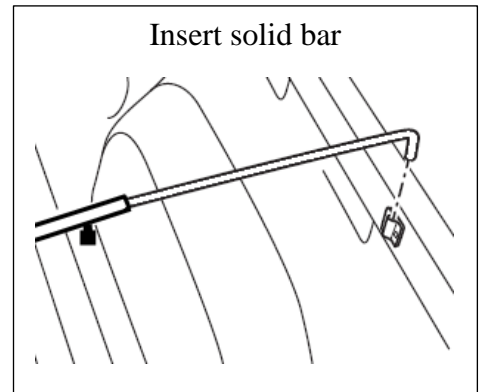

## 6. Fit Tonneau Cover

- (a) Slide the front rope of the tonneau cover into the rope track and centre the cover then drape the cover over the head board.
- (b) Clip the driver's side of the cover onto the driver's side extrusion then attach the passenger side of the cover using the pull loops in the corners to help stretch the cover.
- (c) Clip the plastic onto the tailgate extrusion using the pull loops in the corners to help stretch the cover.
- (d) You can adjust your tonneau, to make it tighter or looser, by simply raising or lowering the height of your tonneau support bar.

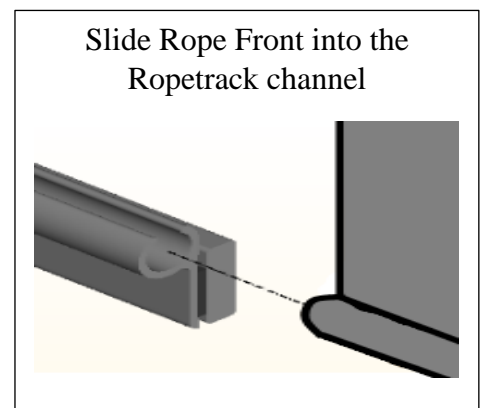

## Tonneau Cover Tethering System



- Rivet the extra Metal Bracket to the Front Driver Side Rail.
- Untie the end of the rope of the Cover and loop it through the Metal Bracket.
- Rethread the Washer and tie the end of the rope into a knot.

## 2. HOW TO FIT INTERNAL ELASTIC SHOCK CORD

- Tie a knot in one end of shock cord.
- Pull shock cord through all plastic hooks.
- Feed the shock cord through loops on the cover.
- Tie a knot at the other end
- Space the hooks as required
- Use washers to tie off rope

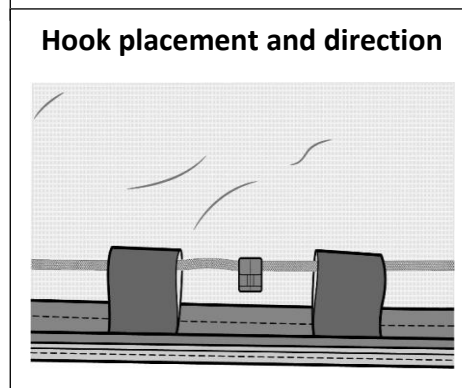
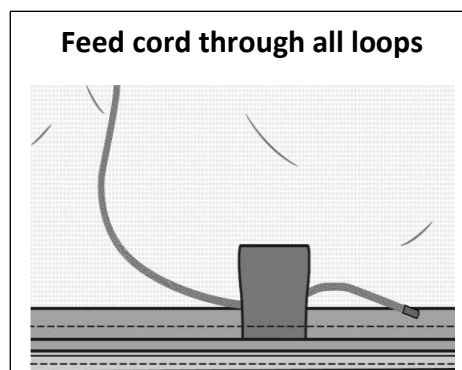
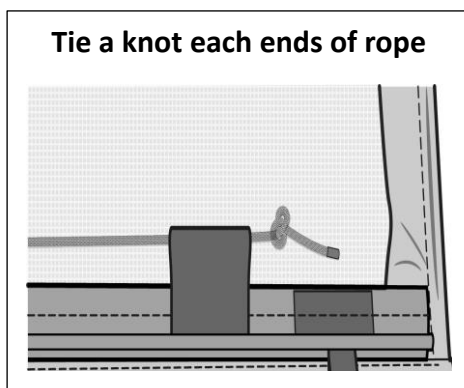

Using Internal Elastic Shock Cord:

The plastic clips on the internal shock cord can be hooked into the aluminium extrusions so that the cover can still be secured with larger loads in the tub.