

Mazda BT-50
With Factory Sports Bars Clip In Tonneau
2012 - Current

Fitting Instructions

Description	QTY	Notes
Tonneau Cover	1	
Front Side RAIL	2	445mm Long
Rear Side RAIL	2	760mm Long
Shock Cord	1	
Rope Hooks	4	
S/S M8 Washer	2	
Tailgate RAIL	1	1380mm Long
Support Bar	1	
Bar Bracket	2	
4 mm Rivets	18	
Fitting Instructions	1	

Tools Required:

Drill, 4.5mm Drill Bit, Rivet Gun, Marker, Tape Measure

Step 1: Attach Front Side Rails

Attach the Front side Aluminium Rails (455mm Long)

Centre the RAIL between the sports bars. Ensure the aluminium is square with the top of the tub.

Measure and mark a spot 50mm in from each end and 30mm up from the bottom edge of the rail.

Drill through these locations into the tub using a 4.5mm drill bit. Then rivet into place.

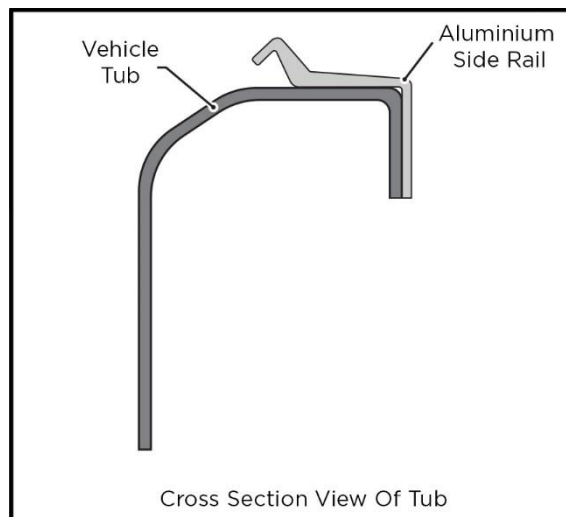

Step 2: Attach Rear Side Rails

Attach the Rear side Aluminium Rails (760mm Long)

Position the rail behind the sports bars. Ensure the aluminium is square with the top of the tub.

From the front edge of the rail, 30mm from the bottom edge, measure and mark the following locations:

90, 123, 375 and 630mm.

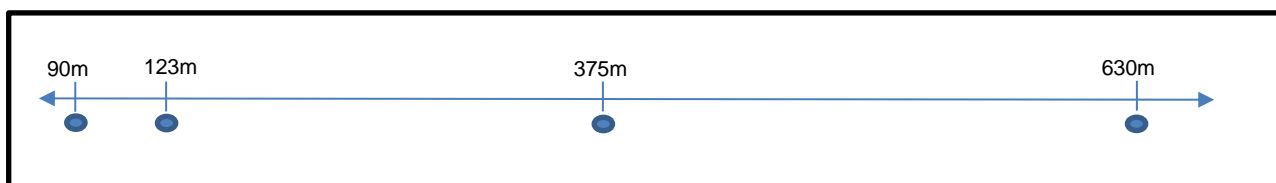
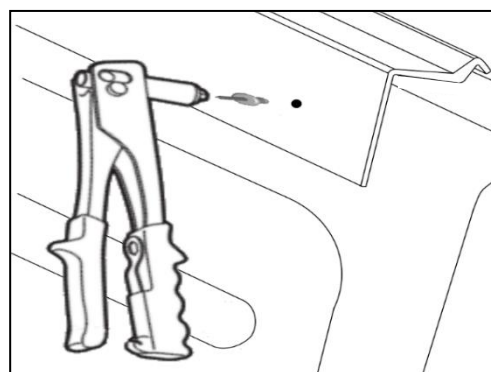

Drill through these locations into the tub using a 4.5mm drill bit. Then rivet into 375mm and 630mm.

Attach the bar bracket by placing a 4mm rivet through each hole of the bracket and into the centre holes in the RAIL.

Rivet remaining holes (90mm and 123.5).

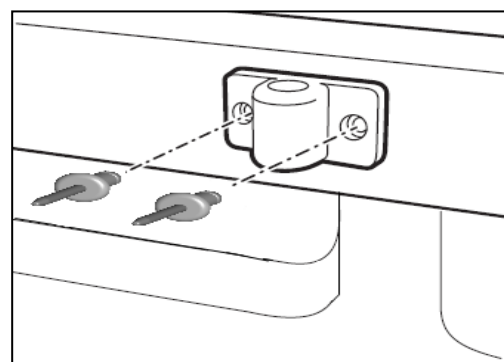

❖ Repeat step 1 and 2 for the other side.

Step 3: Attach Tailgate Rail

Measure and mark the centre, and 325mm and 650mm from the centre of the rail, 30mm from the bottom edge.

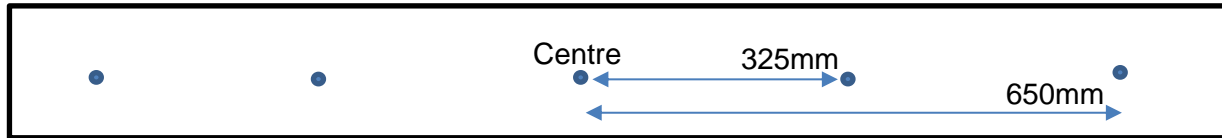

Position the aluminium in the centre of the tailgate, so that it is sitting square with the top surface of the tailgate.

Drill through each of the holes in the aluminium rail into the tailgate.

Rivet the tailgate rail to the tailgate to complete the attachment.

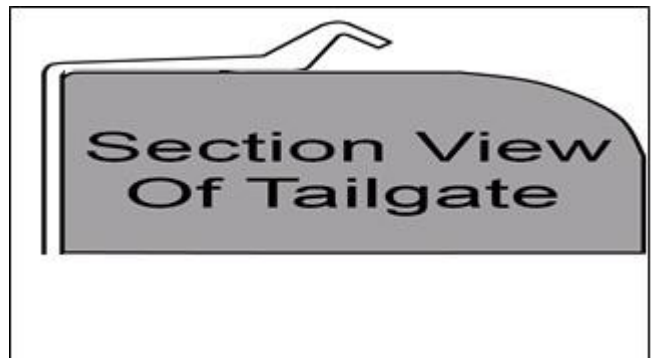

Step 4: Fit Support Bar

Insert solid bar pieces into either end of hollow tube. Place the bar into the Bar Brackets and centre the hollow tube. Adjust the hollow tube so the holes are facing to the ground (this prevents the grub screws rubbing against the tonneau). Tighten the grub screws to secure the hollow tube into place.

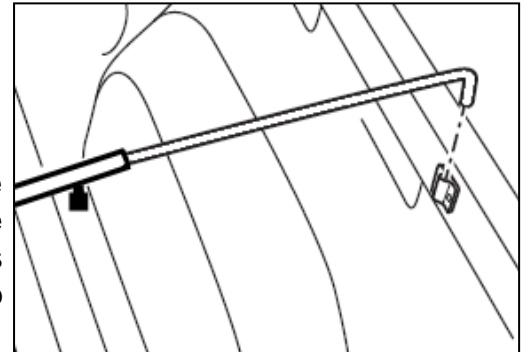

Step 5: Fit Cover

Fit the front of the Tonneau Cover to the front of the Ute tub placing the Plastic Retainer (Fitted on the Tonneau Cover) on to the Metal Lip on the Body, between the cabin and the Ute Body. (Behind rear windscreen). Clip the plastic onto the tailgate RAIL.

Clip the driver's side of the cover onto the driver's side RAIL then attach the passenger side of the cover.

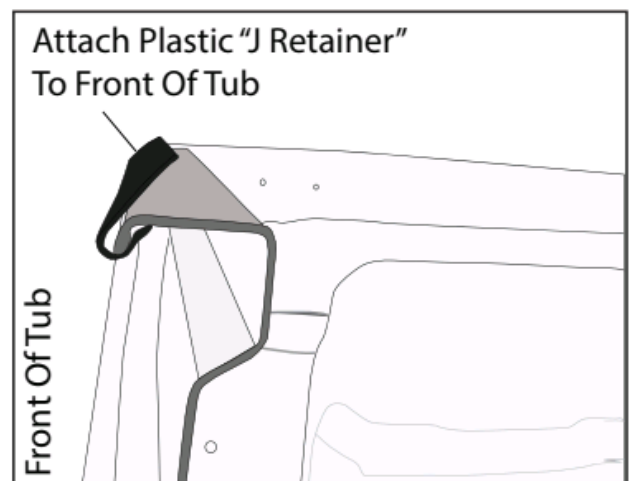

You can adjust your tonneau, to make it tighter or looser, by simply raising or lowering the height of your tonneau support bar.

How to Fit Internal Elastic Shock Cord

To be used for covering larger loads

- Tie a knot in one end of the shock cord.
- Pull shock cord through all plastic hooks.
- Feed the shock cord through loops on the cover.
- Tie a knot at the other end.
- Space the hooks as required.
- Use washers to tie off rope.

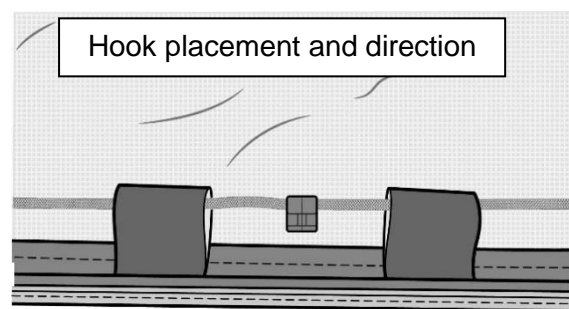
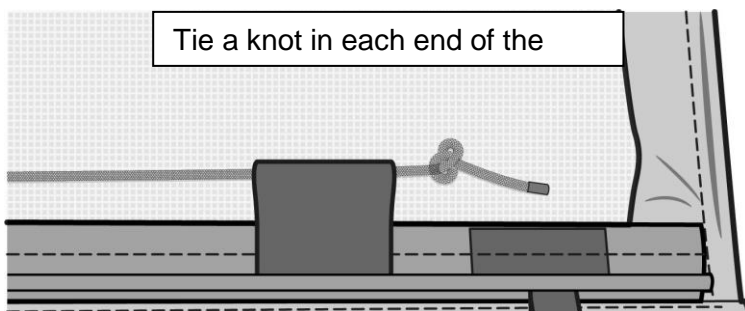
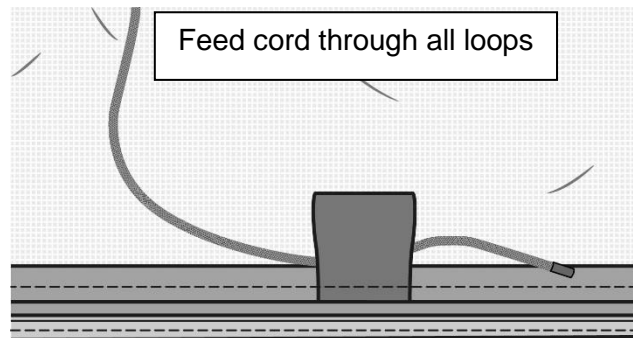

To remove cover once fitted peel cover away from Aluminium clip in rail by peeling away from the edge of the plastic.

IMPORTANT: Do not use cover corners to lift. Always use plastic edges.

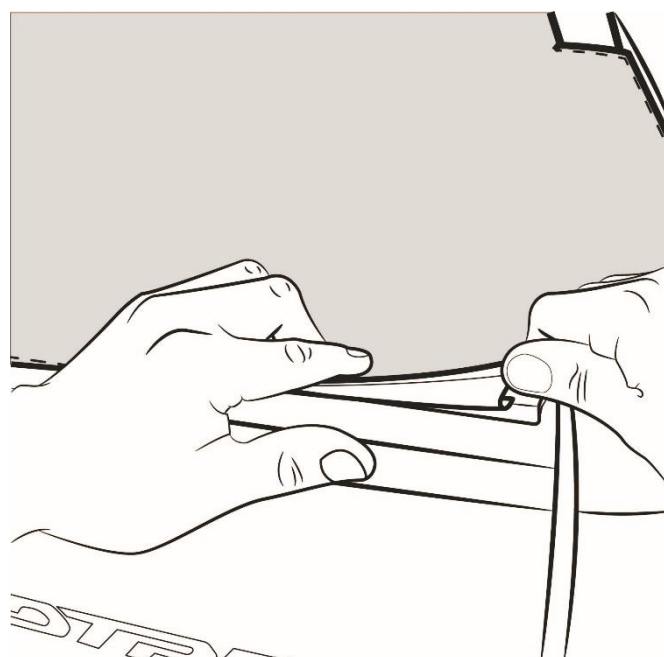

How To Easily Attach & Detach Your Clip On Cover



No more ugly pull tabs, tearing covers, or needing Arnold-like strength with this method!

- Visit the following link: <http://bit.ly/AT-CLIP>
- Or simply scan the QR code. Open your camera app and point it here to see the video! → → →

