

TONNEAU COVER FITTING INSTRUCTION

Madza BT-50 Dual Cab

Without Sport Bar and Headboard

November 2011 – September 2020

Part Number: ATB01658

1. TONNEAU COVER FITTING

NOTE: Please read the entire fitting instruction prior to commencement.

1.1 BASIC TOOLS REQUIRED

Drill, 4mm Drill Bit, Rivet Gun, Marking Pencil / Pen, 4mm Allen Key, Straight Edge or String Line

1.2 CONTENTS

1 x Tonneau Cover	2 x Bar Brackets
1 x Tonneau Support Bar	24 x Rivets
1 x Fitting Instruction	18 x Rope Buttons

1.3 TONNEAU COVER INSTALLATION PROCEDURE

1. Attach The Bar Brackets

- To fit the bar brackets, measure 720mm back from the inside front edge at the top of the tub and place them as shown in **Figure 1** (5mm down from top edge of tub). Drill and rivet using two large rivets for each Bar Bracket. Install the support bar according section 3.

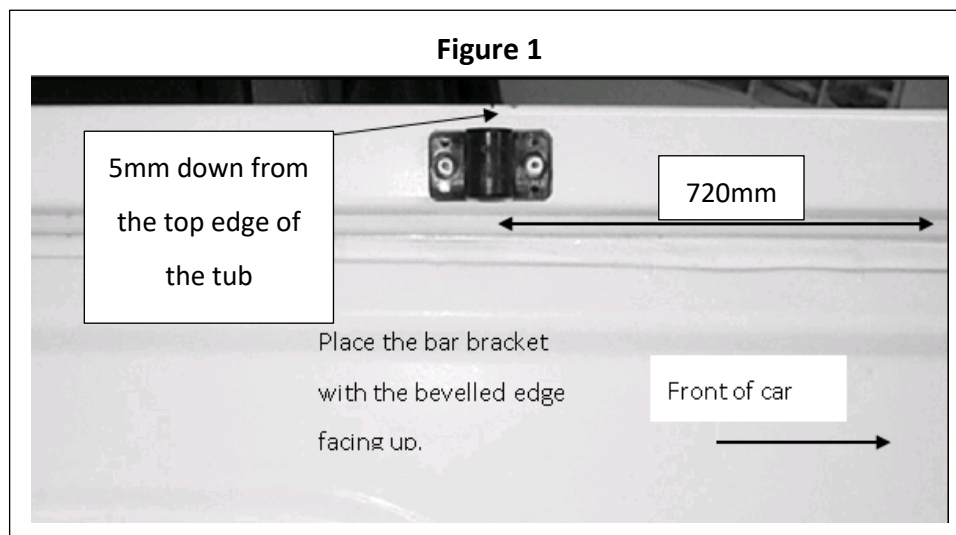

2. Fitting Tonneau Cover:

- Place Tonneau Cover over Support Bars and secure the 'J' plastic retainer to the front rail.
- Pull the rear of the cover over the tailgate to make cover taut. Hinge the plastic over the top edge of the rail.
- Keep pressure and push the hook of the plastic over the bottom lip of the rail to secure into place.
- Secure the cover along the entire length of the tailgate rail and repeat the process for the passenger and driver side of the tub.

3. Fit buttons to the tail gate

- Measure 495mm up from the bottom edge of the tail gate and 55mm for the outer button. **See Figure 2.**

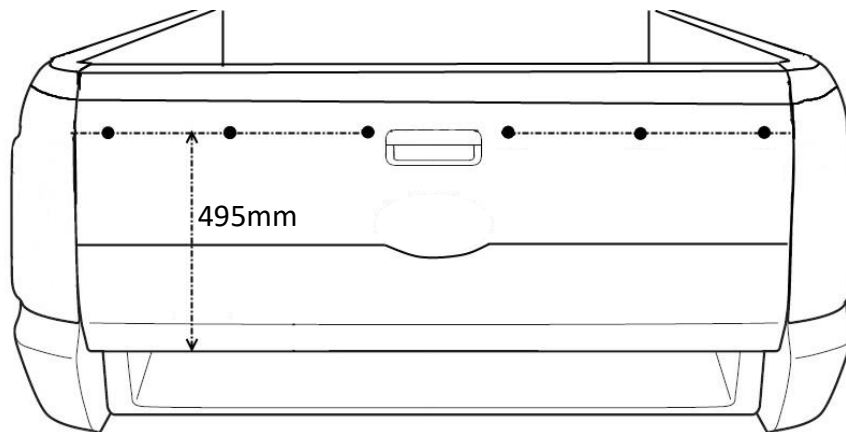

- Then 470 up and 305mm & 560mm in from the outside edge of the driver's side of the tailgate and mark button positions.
- Repeat for the passenger side of vehicle.
- Drill holes then rivet buttons into place.

4. Fit buttons to drivers side body.

- Measure down 170mm from the inside edge of the tub, and back 35mm from the front outside edge of the tub and mark. **This is the position of the front button.**
- Position No.2 down 170mm back 285mm No.3 down 170mm back 530mm No.4 down 170mm back 770mm No.5 down 165mm back 1020

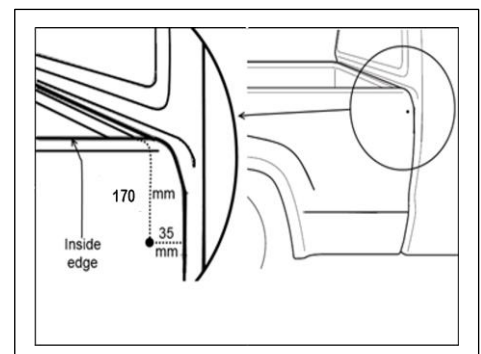

- Measure down **155mm** from the inside edge of the tub, and forward **5mm** from the front outside edge of the tailight and mark.

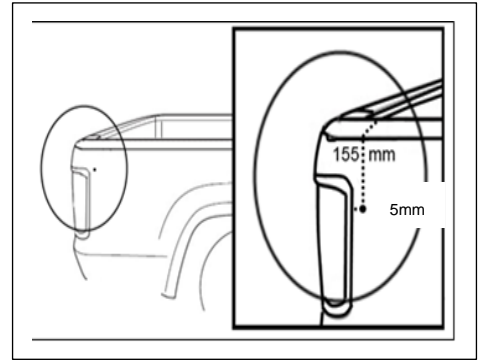

2. CARING FOR YOUR TONNEAU

Apply bee's wax or Dri-lube to stitching a few times a year, as this will maintain the tonneau's waterproofing ability and prevent the stitching from degrading. Use a mild detergent and soft scrubbing brush to clean tonneau.

Never drive without tonneau support bars in place as flapping can cause a delaminating effect on the material.

"Tonneau is not designed to be used as a load restraint"

3. MULTI-FIT SUPPORT BAR

- The Aussie Tonneau Multi - Fit Support Bar is designed to fit almost all Utes on the Market, from Suburu Brumbys to Cab Chassis aluminium trays
- Insert solid bar pieces into either end of hollow tube. Adjust bar so it fits between bar bracket holders with the holes facing to the ground (so the grub screws don't rub against the tonneau), as shown above and then with a white pencil make a mark through the small holes of the hollow bar onto the solid ends. This is where you will drill a hole to the depth of about 1-2mm (do not go any further)
- Join the pieces back together and screw grub screws through the hollow bar into the holes that you drilled. **Make sure you do not over tighten the grub screws.** Then place the tonneau sheath over the bar to stop the bar wearing against the tonneau. Refit the bar. You may kink the bar in the middle to give it some extra height to assist with water runoff.

Warning if you do not fit the tonneau sheath over the bar, the tonneau cover will quickly wear through which is not covered by warranty.