

# TONNEAU FITTING INSTRUCTION

## Isuzu D-Max Space Cab

September 2020 - Current

**Part number: ATB01395**

### Package includes

1 X Tonneau cover	4 x Bar Brackets
2 x Tonneau Support Bar	30 x Rivets
1 x Fitting Instructions	18 x Rope Buttons

## 1. TONNEAU COVER FITTING

**NOTE** Read entire instructions prior to start.

## 1.1 BASIC TOOL REQUIRED

Drill, 4mm Drill Bit, Rivet Gun, Marking Pencil / Pen

## 1.2 TONNEAU COVER INSTALLATION PROCEDURE

### 1. Fit The Bar Brackets and Support Bars

- (a) Measure **600mm** and **1200mm** from the front inside edge back along the driver's side. Place centre of Bar Bracket at these points with the top of Bar Bracket 10mm down from top edge of tub. Using the Bar Bracket as a guide, drill into the body.
- (b) Apply rust inhibitor and rivet the front and rear holes to complete attachment of the Bar Bracket. Repeat for the passenger side of vehicle.
- (c) Fit Support Bar according to Section 3 of this Instruction.

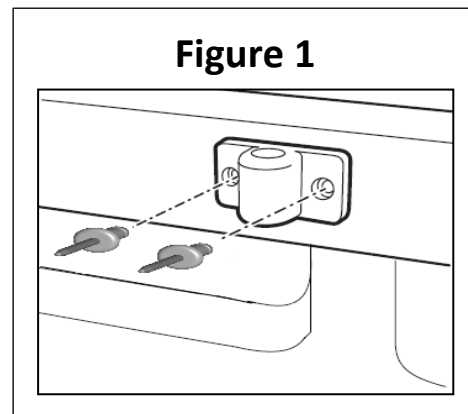

### 2. Fit The Buttons To The Tailgate

- (a) Hook the front of the Cover onto the front edge of the Ute Tub. Centre the cover and evenly spread across the tub.
- (b) To fit buttons, vertically line up each button to each bunji loop, **Starting from the Centre Bunjis**. The height of the 6 Tailgate Buttons are 460mm from the bottom edge of the tailgate.
- (c) Drill holes then apply rust inhibitor and rivet buttons into place, attaching the bunji after each button is placed. **See Figure 2**

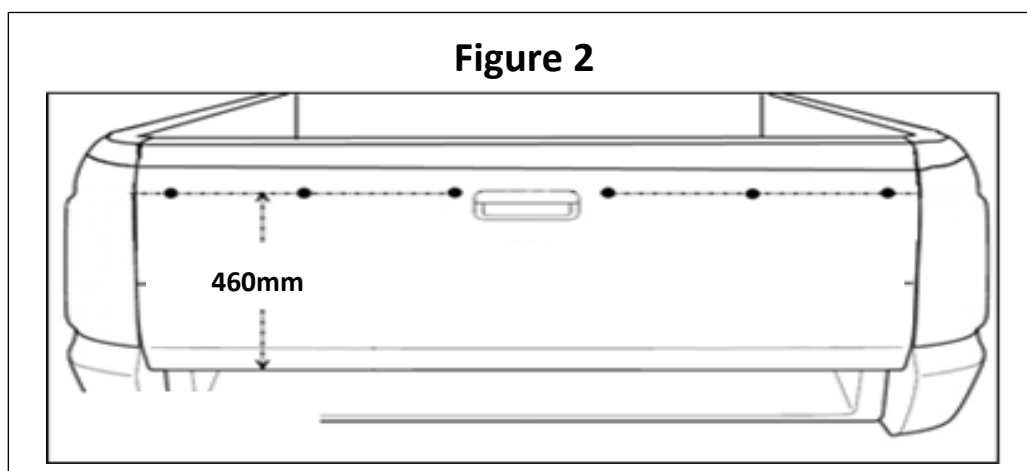

### 3. Fit The Buttons To Tub Sides

(a) Measure down **170mm** from the inside edge of the tub, in line with the Front Bunji on the Cover, and mark. **This is the position of the front button.** See **Figure 3**

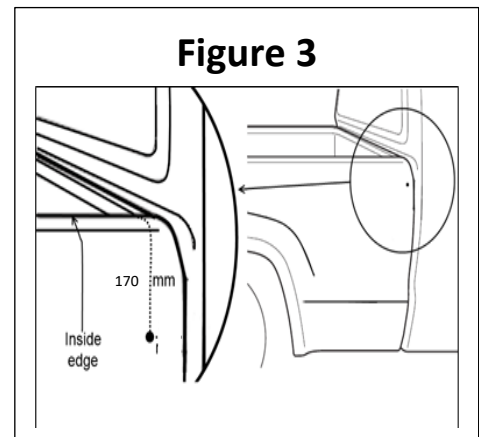

(b) Measure down **140mm** from the inside edge of the tub, in line with the Rear-Side Bunji and mark. See **Figure 4**

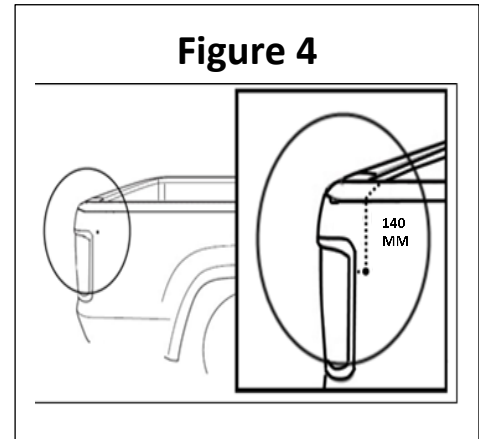

(c) Using a straight edge or string line, draw a line between front mark & rear mark as shown in **Figure 5**

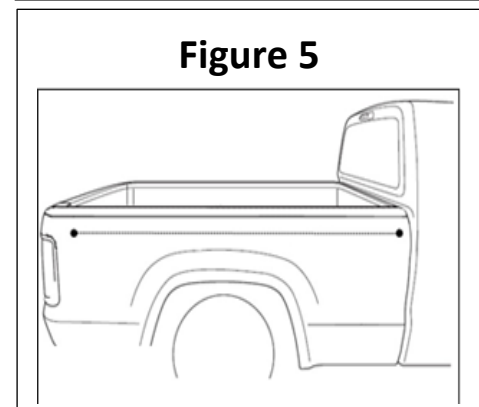

(d) Repeat those steps for passenger side

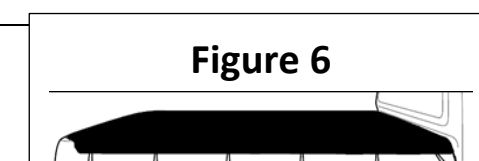

- (e) Work from the rearmost bunjis towards the front, alternating from side to side.
- (f) Line up the rearmost bunji loop (#1) on the driver's side of the vehicle and make a mark on the line drawn in step 4 (c).
- (g) Drill hole and rivet button into place as shown in **Figure 12**.
- (h) Repeat step 3 (e) to (g) for the rear most bunji loop (#2) on the passenger side of the vehicle.
- (i) Fit remaining 10 bunjis following the sequence as in **Figures 6 & 7**.

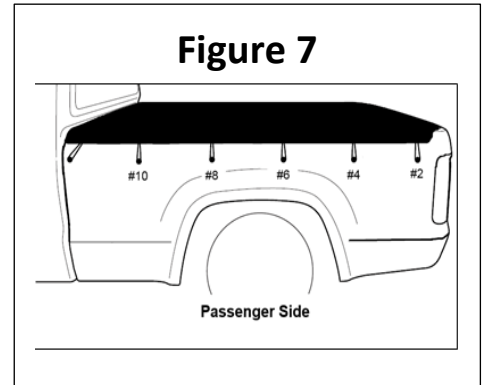

**Note: Ensure you work from side to side to maintain tension across the tonneau cover**

## 2. MULTI-FIT SUPPORT BAR

### 3.1 BASIC TOOL REQUIRED

Drill, 4mm drill bit

### 3.2 MULTI-FIT SUPPORT BAR CONTENTS

- 1 x hollow bar centrepiece
- 2 x grub screws
- 2 x solid bar end piece

### 3.3 FITTING MULTI-FIT BAR

1. Insert solid bar pieces into either end of hollow tube. Adjust bar so it fits between bar bracket holders with the holes facing to the ground (so the grub screws don't rub against the tonneau)
2. **Make sure you do not over tighten the grub screws.** You may kink the bar in the middle to give it some extra height to assist with water runoff.