

TONNEAU COVER FITTING INSTRUCTION

LDV T60 Crew Cab

With Sport Bar

2017 – Current

Part Number: ATB01293

1. TONNEAU COVER FITTING

NOTE: Please read the entire fitting instruction prior to commencement.

1.1 BASIC TOOLS REQUIRED

Drill, 4mm Drill Bit, Rivet Gun, Marking Pencil / Pen, 4mm Allen Key, Straight Edge or String Line

1.2 CONTENTS

1 x Tonneau Cover

2 x Bar Brackets

1 x Tonneau Support Bar

24 x Rivets

1 x Fitting Instruction

18 x Rope Buttons

1.3 TONNEAU COVER INSTALLATION PROCEDURE

Fitting the Support Bar Brackets and the Support Bar.

1. To fit the support bar brackets, measure 735mm back from the inside front edge at the top of the tub and then place them as shown in **Figure 1**. (10mm from top edge of tub).

Next drill and rivet using two rivets for each Bar Bracket.

Figure 1. Placement of bar bracket.

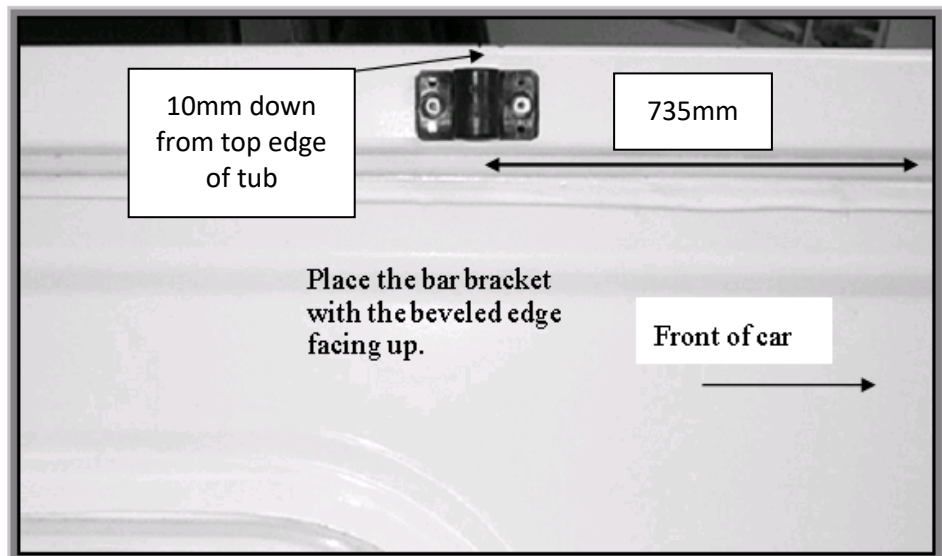

2. Insert solid bar pieces into either end of hollow tube. Adjust the bar length so it fits into the bar bracket holders with the welded nuts facing to the ground (so that the grub screws don't rub against the cover). Use 4mm Allen Key to tighten grub screws.
3. **NOTE: The height of Support Bar above top edge of tub should be 55mm.**
The solid bars can be bent slightly to gain height when bars are assembled.
4. Place the bar sheath over the bar to protect the Tonneau Cover from wear.

Fitting the Tailgate Buttons.

5. Refer to **Figure 2** to mark the 6 tailgate button positions.
 - Measure 438mm up from the bottom edge of the tailgate and 35mm in from the left and right hand side edges, mark the button positions.
 - Measure 444mm up from the bottom edge of the tailgate and 305mm in from the left and right hand side edges, mark the button positions.
 - Measure 447mm up from the bottom edge of the tailgate and 353mm in from the left and right hand side edges, mark the button positions.

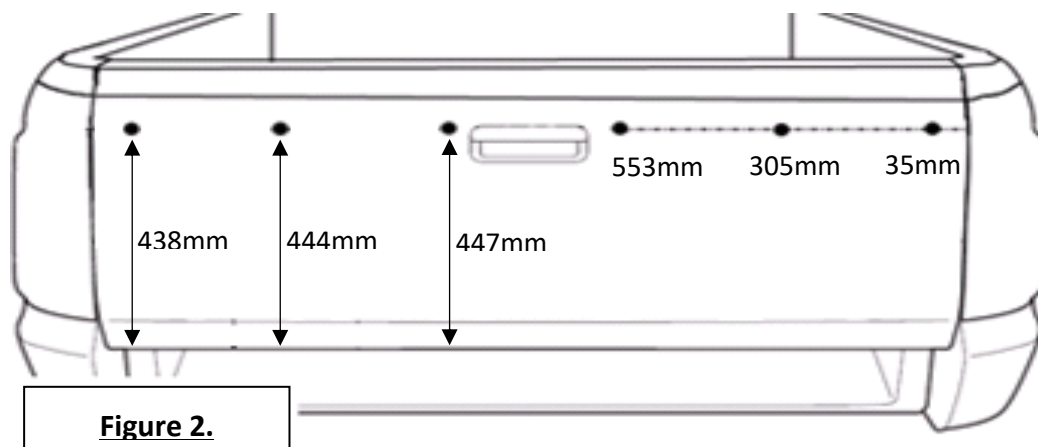

Fitting the Side Buttons.

6. Attach the 'Plastic Retainer' (sewn onto the front of the cover) to the Metal Lip between the vehicle cabin and Ute Body.
7. Drape the cover over the support bar and fit rear bunji's to buttons on the tailgate.
8. Measure down 125mm from the top of the tub, and back 60mm from the front outside edge of the tub and then mark the position. See **Figure 3** below.

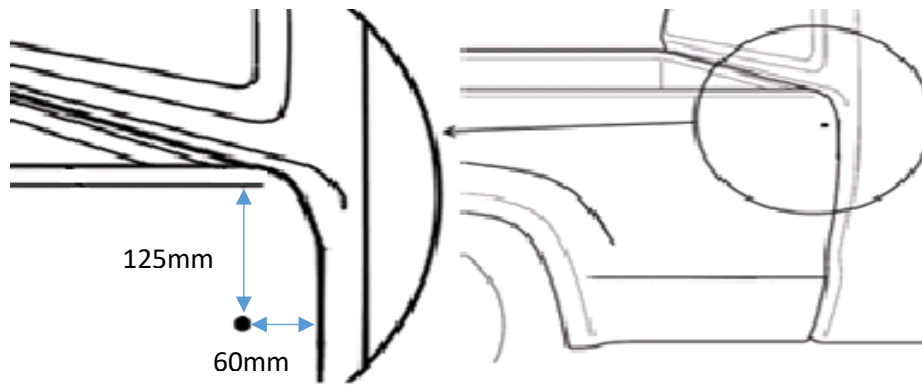

Figure 3.

9. Measure 105mm down from the top of the tub, in line with the last bunji on the side of the cover.

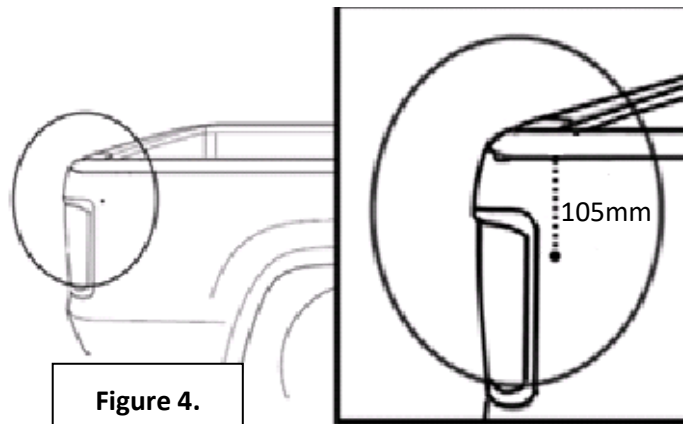

Figure 4.

10. Using a Straight Edge or a String Line, draw a line between front mark and rear mark.

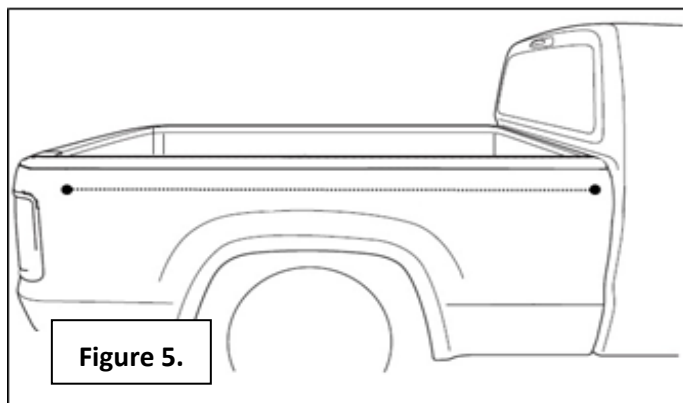

Figure 5.

11. To fit the Buttons to the side of tub:

- Work from the rear most bunjis towards the front, alternating from side to side.

- Line up the rear most bunji (#1) on the driver's side of the vehicle and make a mark on the line drawn in Step 10 above.

(Non-Sports Bar model shown in **Figures 6 and 7**, but the button position is the same as for the Sports Bar model)

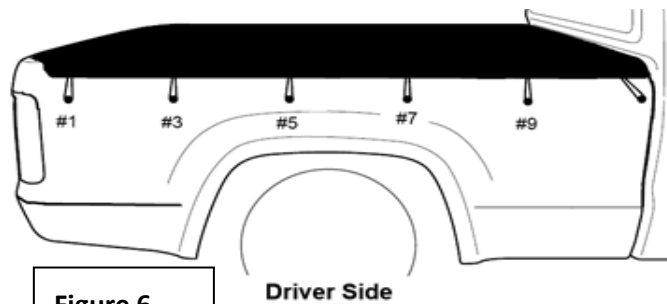

- Drill the holes and then rivet the buttons into place.
- Repeat for the Passenger side of vehicle (#2)

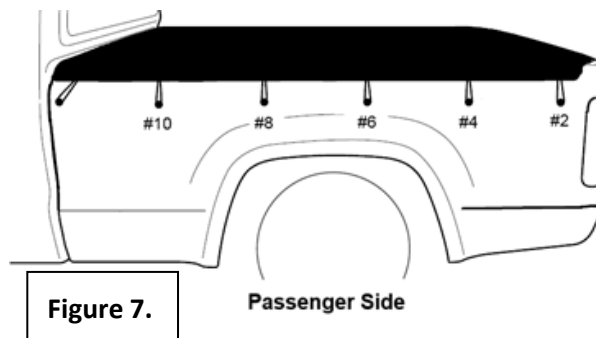

- Fit the remaining buttons following the sequence in **Figures 6 and 7**.
- Attach each bunji as the buttons are riveted into place

2. CARING FOR YOUR TONNEAU

Apply bee's wax or Dri-lube to stitching a few times a year, as this will maintain the tonneau's waterproofing ability and prevent the stitching from degrading. Use a mild detergent and soft scrubbing brush to clean tonneau.

Never drive without tonneau support bars in place as flapping can cause a delaminating effect on the material.

"Tonneau is not designed to be used as a load restraint"