

TONNEAU COVER FITTING INSTRUCTION

MITSUBISHI MQ/ MR

DUAL CAB WITH SPORT BAR

JULY 2015 – CURRENT

PART NO: ATB01256

BASIC TOOLS REQUIRED

Drill, 4mm Drill Bits, Rivet Gun, Marking Pencil/ Pen

CONTENTS

- 1 x Tonneau Cover
- 1 x Tonneau Support Bar
- 2 x Angle Aluminium
- 1 x Fitting Instruction
- 2 x Bar Brackets
- 34 x Rivets
- 18 x Rope Buttons

1. INSTALLATION PROCEDURE

1. Place the 50 x 25mm angle on the front top edge of the Ute. The 50mm wall of the angle needs to be vertical.
2. The edges of the angle will sit against the sports bar mounts on the side wall of the tub. *See Figure 1*
3. Drill 5 evenly spaced holes through the 25mm section of the angle and into the top edge of the tub.
4. The first hole from each end will be about 130mm from the end of the angle. Pop rivet into place. *See Figure 2*
5. Sit and centralize the 20 x 20mm angle on top of the 50 x 25mm angle.

Figure 1



Figure 2



6. Drill 5 evenly spaced holes through the smaller angle, into the larger one already fitted. **See Figure 3**

7. The first hole needs to be 30mm from each end.

8. Pop rivet the smaller angle to the larger one.

9. To fit the bar brackets, measure 735mm back from the inside front edge at the top of the tub and place them as shown in **Figure 4**. (15mm from top edge of tub).

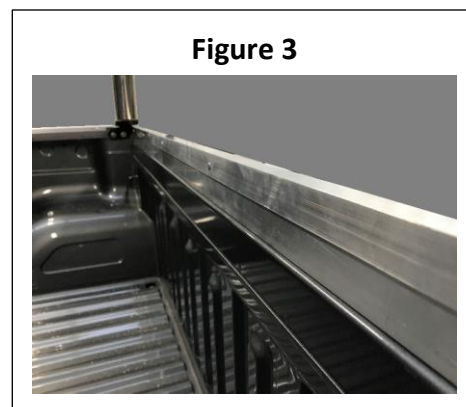
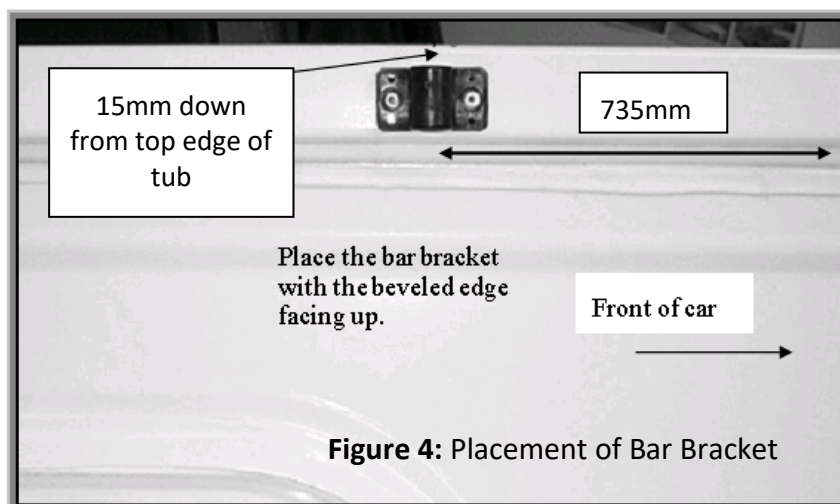

Figure 3



10. Drill and rivet using two large rivets for each Bar Bracket.

11. Fit your tonneau cover support bar into position, using instructions over page. Drape cover over support bars.

12. To fit the rope buttons to the tailgate measure 465mm up from the bottom edge on both sides of the tailgate and mark. With a straight edge draw a line between these two marks. **See Figure 5**

13. Centre the cover and mark the position of each bunji loop on the line drawn in step 12.

14. With a 4mm drill bit drill holes in these positions and pop rivet a rope button to the tailgate. Attach the rear bunji loops to the buttons as you go. **See Figure 6**

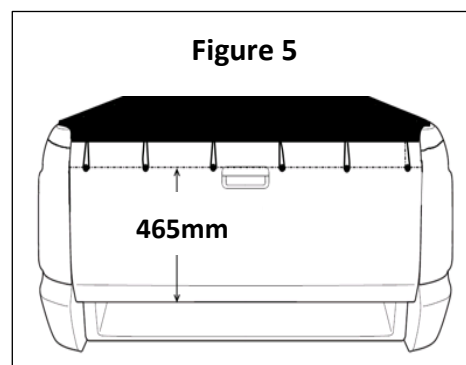

Figure 5

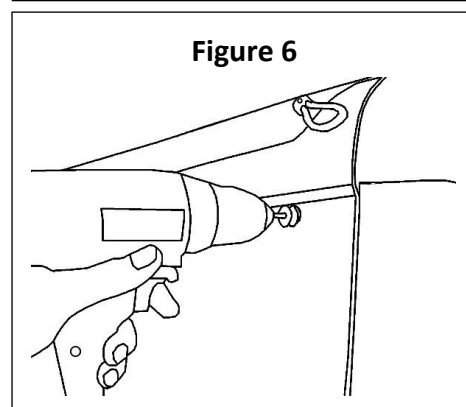

Figure 6

15. To fit the rope buttons to the sides of the tub measure and mark 160mm from the inside edge of the tub next to the headboard, down the outside of the tub. **See Figure 7**

16. From where the last bunji is situated on each side measure and mark 120mm from the inside edge of the tub down the outside.

17. With a straight edge draw a line between the two positions marked in step 15 and 16. On this line mark the positions of each side bunji except for the front bunji on each side.

18. For the front bunji place a mark on the line 50mm from front of tub. **See Figure 8**

19. With a 4mm drill bit drill holes in these positions and pop rivet a rope button to the tub. Attach the bunji loops to the buttons as you go.

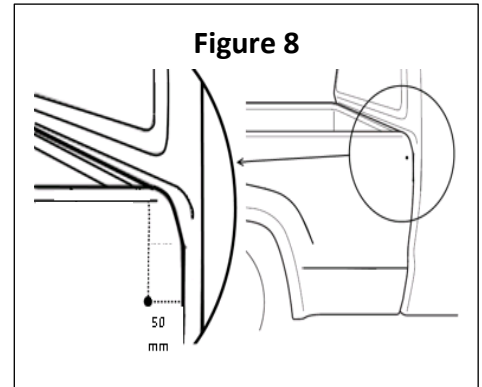
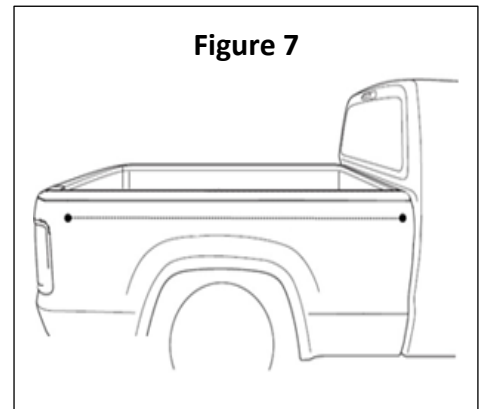

2. MULTI-FIT SUPPORT BAR

The Aussie Tonneau Multi - Fit Support Bar is designed to fit almost all Utes on the Market, from Subaru Brumbys to Cab Chassis aluminium trays.

2.1 BASIC TOOL REQUIRED

- Drill, 4mm drill bit

2.2 MULTI-FIT SUPPORT BAR CONTENTS

- 1 x hollow bar centrepiece
- 2 x grub screws
- 2 x solid bar end piece

2.3 FITTING MULTI-FIT BAR

1. Insert solid bar pieces into either end of hollow tube. Adjust bar so it fits between bar bracket holders with the holes facing to the ground (so the grub screws don't rub against the tonneau), as shown above and then with a white pencil make a mark through the small holes of the hollow bar onto the solid ends. This is where you will drill a hole to the depth of about 1-2mm (do not go any further)

2. Join the pieces back together and screw grub screws through the hollow bar into the holes that you drilled. **Make sure you do not over tighten the grub screws.** Refit the bar. You may kink the bar in the middle to give it some extra height to assist with water runoff.