

TONNEAU COVER FITTING INSTRUCTION

Toyota Hilux SR5 A Deck Extra Cab

Without Sport Bar & Headboard

October 2015 – Current

Part Number: ATB01232

1. TONNEAU COVER FITTING

NOTE: Read entire instructions prior to start.

1.1 BASIC TOOL REQUIRED

Drill, 4mm Drill Bit, Tape Measure, Rivet Gun, Marking Pencil / Pen, Clear Silicone / Silicone Gun

1.2 CONTENTS

1 x Tonneau Cover	2 x Bar Brackets
1 x Tonneau Support Bar	24 x Rivets
1 x Fitting Instruction	18 x Rope Buttons

1.3 TONNEAU COVER INSTALLATION PROCEDURE

1. To fit bar brackets measure 810mm back from the inside front edge at the top of the tub and place them as shown in (5mm down from top edge of tub). Drill and rivet using two large rivets for each Bar Bracket. Install support bar according to supplied instructions. **See Figure 1**
2. Fit Round Body Hooks (Buttons) to Tailgate. **See Figure 2**

With a non-permanent marker mark the positions of the rear buttons.

- The first two are 30mm in from either side of the tailgate and 455mm from the bottom of the tailgate.
 - The next two are 242mm in from the sides of the tailgate and 455mm from the bottom of the tailgate.
 - The last two are 452mm in from the sides of the tailgate and 460mm from the bottom of the tailgate.
3. Fit Round Body Hooks (Buttons) to the Sides
 - Firstly attach the front of the Tonneau to the front of the ute tub placing the Plastic Retainer (Fitted on the Tonneau Cover) on to the Metal Lip on the Body, between the cabin and the Ute Body. (Behind rear windscreen).

- Centre the cover, place it over the support bar and attach the rear bunji loops to the buttons on the tailgate.
- On each side with a non-permanent marker mark 130mm down from the inside edge of the tub near the rear bunji.
- Also on each side, mark 135mm down from the inside edge of the tub near the front bunji.
- With a straight edge or string line draw a straight line between these two positions.
- Vertically line up each button to each bunji loop starting from the rear bunji loop, alternating from side to side working towards the front. Attach each bunji to the button as it is fitted.

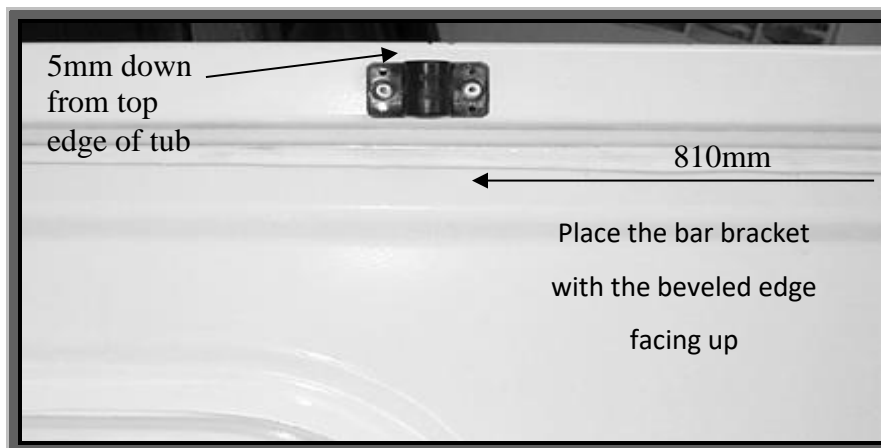

Figure 1

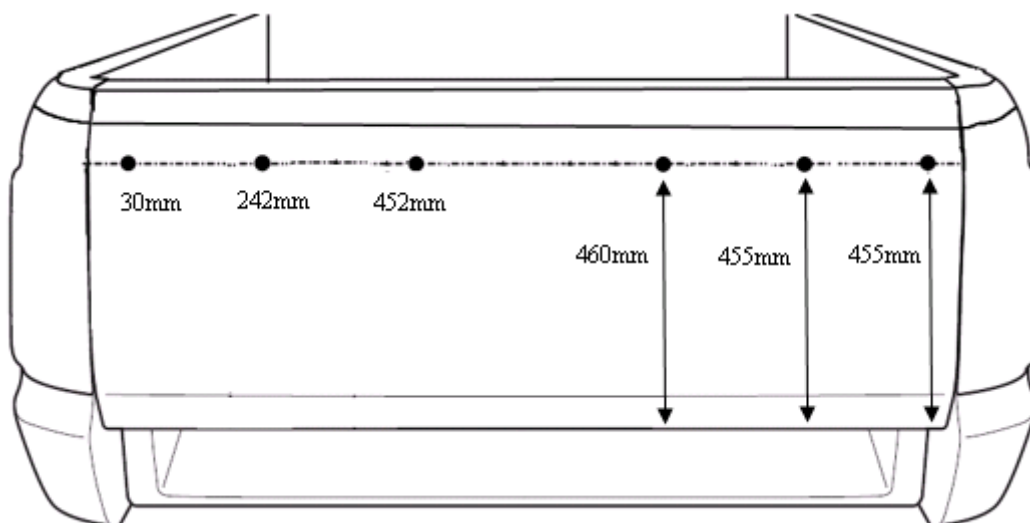

Figure 2

2. CARING FOR YOUR TONNEAU

Apply bee's wax or Dri-lube to stitching a few times a year, as this will maintain the tonneau's waterproofing ability and prevent the stitching from degrading. Use a mild detergent and soft scrubbing brush to clean tonneau.

Never drive without tonneau support bars in place as flapping can cause a delaminating effect on the material.

"Tonneau is not designed to be used as a load restraint"

3. MULTI-FIT SUPPORT BAR

The Aussie Tonneau Multi - Fit Support Bar is designed to fit almost all Utes on the Market, from Suburu Brumbys to Cab Chassis aluminium trays.

3.1 BASIC TOOL REQUIRED

Drill, 4mm drill bit

3.2 MULTI SUPPORT BAR CONTENTS

- 1 x hollow bar centrepiece
- 2 x grub screws
- 2 x solid bar end piece

3.3 FITTING MULTI SUPPORT BAR

1. Insert solid bar pieces into either end of hollow tube. Adjust bar so it fits between bar bracket holders with the holes facing to the ground (so the grub screws don't rub against the tonneau), as shown above and then with a white pencil make a mark through the small holes of the hollow bar onto the solid ends. This is where you will drill a hole to the depth of about 1-2mm (do not go any further)
2. Join the pieces back together and screw grub screws through the hollow bar into the holes that you drilled. Make sure you do not over tighten the grub screws. Refit the bar. You may kink the bar in the middle to give it some extra height to assist with water runoff.