

TONNEAU INSTALLATION INSTRUCTIONS

FORD RANGER PX SINGLE CAB WITH HEADBOARD (CHECK IMAGE)

JUNE 2013 – CURRENT

PART NUMBER: ATB01030

BASIC TOOLS REQUIRED

- Rivet gun, Drill, 4.5mm Drill bit, Measuring tape, Silicon sealant, Anti-corrosive primer.

CONTENTS

1 x Tonneau cover	3 x Aluminium rope track (476mm)
4 x Bar Brackets	2 x Tonneau support bar
18 x Buttons	35 x Rivets
4 x Pieces of dowel	1 x Seal Tape
1 x Seal Template	1 x Fitting Instruction

(Some parts in the fitting kit may not be required. All fitting kits are weighed to ensure accurate quantities.)

1. INSTALLATION PROCEDURE

– IMPORTANT –

THE HEADBOARD ON THIS VEHICLE WAS CHANGED IN MAY 2013.

PLEASE REFER TO THE IMAGE BELOW TO CONFIRM THE HEADBOARD ON THE VEHICLE MATCHES THE IMAGE ON THE RIGHT HAND SIDE.

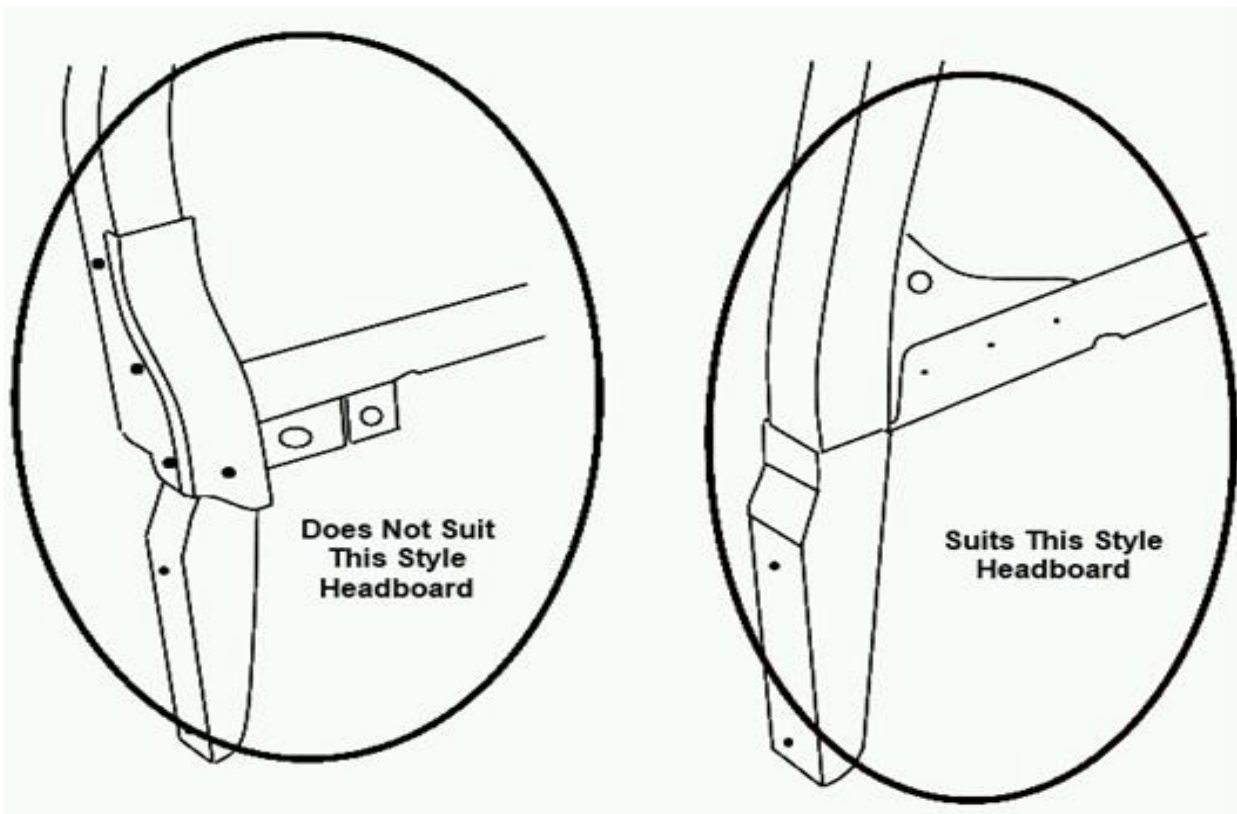

- Using a 4mm drill bit, drill a hole 50 mm in from each end and 9 mm up from the bottom of the 3 pieces of rope track as shown in **Figure 1a**.
- Join the 3 pieces of rope track together using the 2 pieces of wooden dowel as shown in **Figure 1b**

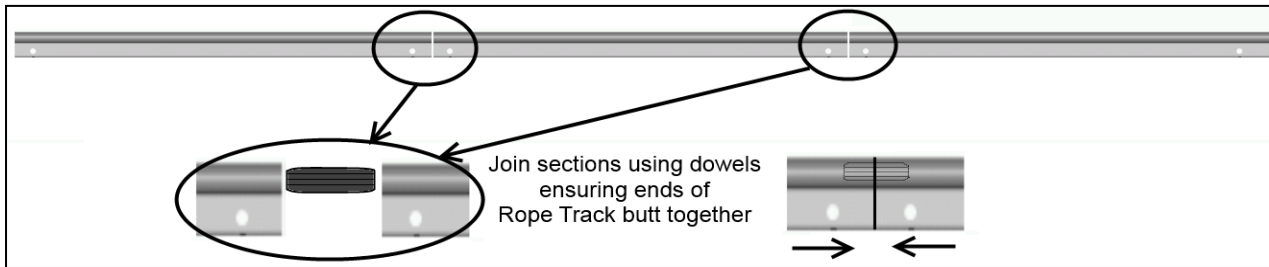
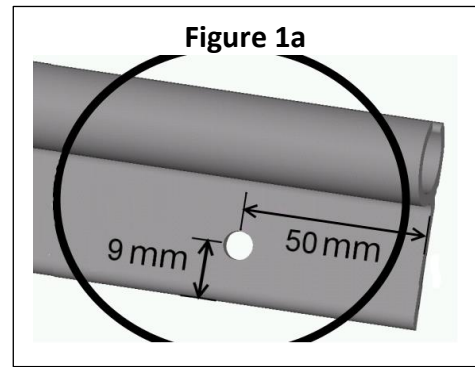
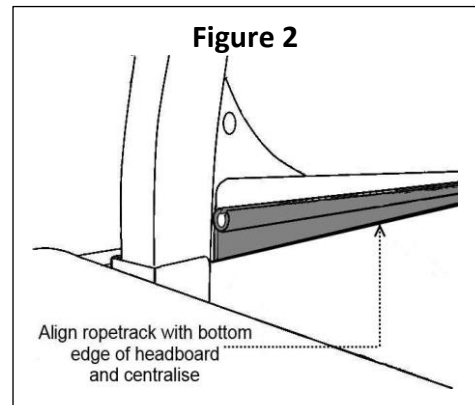

Figure 1b

- Sit the flat side of the assembled rope track on the tailgate side of the headboard with the 'C' channel facing upward and align the bottom edge of the rope track with the bottom edge of the headboard then centralise the rope track as shown in **Figure 2**



- Drill through the holes in the rope track and into the top edge of the tub working from the centre out, placing a 4mm rivet in each hole as it is drilled, but **do not rivet**.

- Once all holes have been drilled, remove the rivets and disassemble the rope track, discard the dowels and clean any swarf from the tub.

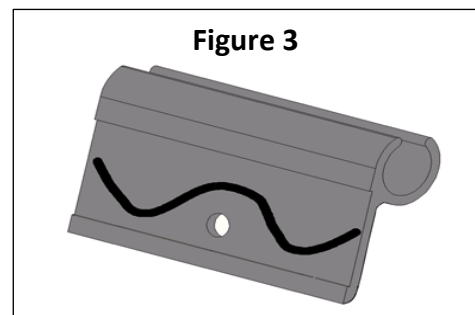

- Apply a bead of silicone to the flat face of the 3 sections of the rope track then rivet the rope track sections into place.

See Figure 3

- To attach bar brackets, measure 740mm from the inside tailgate edge forward along the driver's side. Place centre of Bar Bracket at this point with the top of Bar Bracket 5mm down from top edge of tub. **See Figure 4**

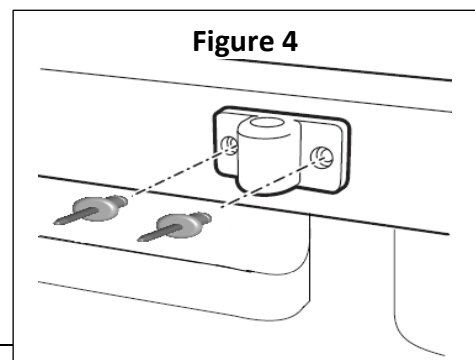

8. Using the Bar Bracket as a guide, drill into the body. Apply rust inhibitor and rivet the front and rear holes to complete attachment of the Bar Bracket. Repeat for the passenger side of vehicle.
9. Measure 465mm up from the bottom edge of the tail gate and 25mm, 295mm & 562mm in from the outside edge of the driver's side of the tailgate and mark button positions. **See Figure 5**
10. Repeat for the passenger side of vehicle. Drill holes then apply rust inhibitor and rivet buttons into place.

Figure 5

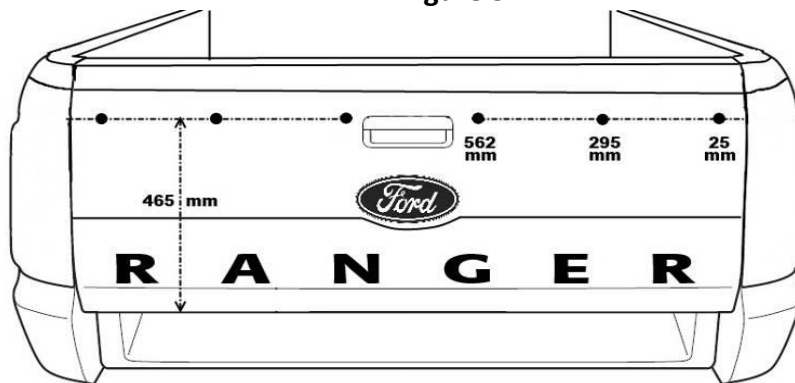

11. Measure down 165mm from the inside edge of the tub, and back 35mm from the front outside edge of the tub and mark. **This is the position of the front button. See Figure 6**

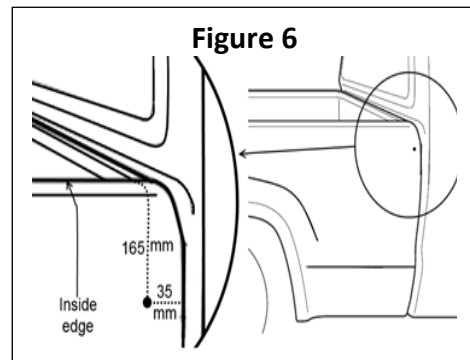

12. Measure down **155mm** from the inside edge of the tub, and forward **10mm** from the front outside edge of the taillight and mark. **See Figure 7**

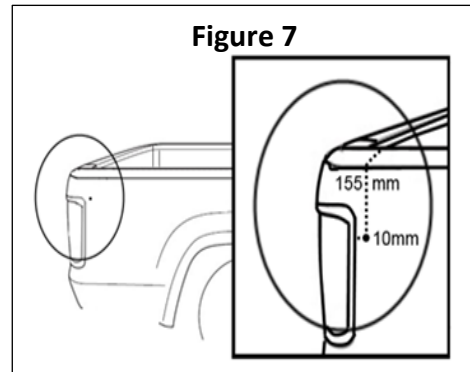

13. Using a straight edge or string line, draw a line between front mark & rear mark as shown in **Figure 8**

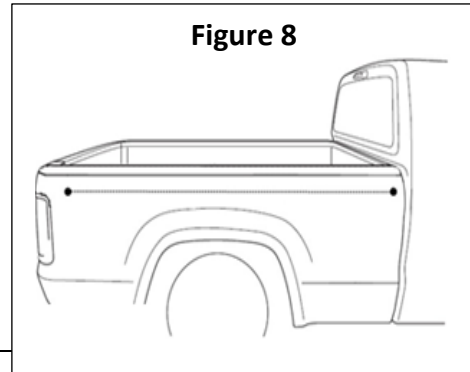

14. Fit the **front button only** to the vehicle by drilling a 4mm hole at the front mark then apply rust inhibitor and rivet button into place.

➤ **Repeat steps 11 to 14 for passenger side.**

15. Slide the front of the tonneau cover into the rope track as shown in **Figure 9** and centre the cover. Drape the cover over the cab.

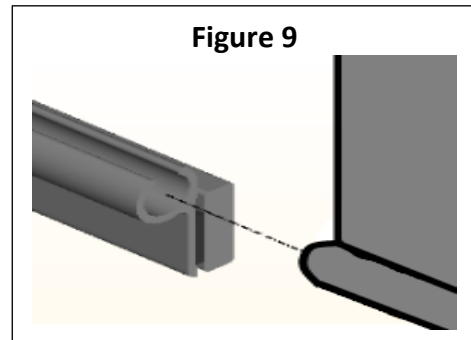

16. Install the support bar (Refer Multi Fit Support Bar Page) then drape cover over support bar and fit rear bunji's to buttons on tailgate as shown in **Figure 10**

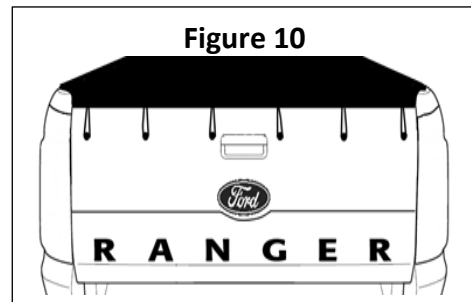

17. To fit side buttons, work from the rear most bunjis towards the front, alternating from side to side. Line up the rear most bunji loop (#1) on the driver's side of the vehicle and make a mark on the line drawn in step 13.

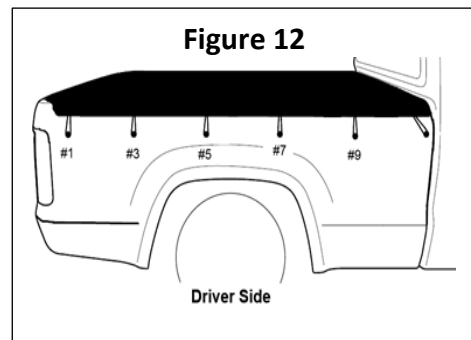

18. Drill hole, apply rust inhibitor and rivet button into place.

19. Repeat step 17 for the rear most bunji loop (#2) on the passenger side of the vehicle.

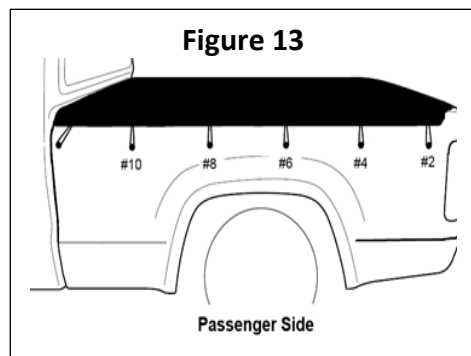

20. Fit remaining 8 bunjis following the sequence as in **Figures 11 & 12**.

Note: Ensure you work from side to side to maintain tension across the tonneau cover.

21. Cut 2 pieces from the supplied seal tape 270mm long. Use the supplied Seal Template to mark and cut 1 piece to suit the driver's side of the headboard and 1 piece to suit the passenger side of the headboard. **Refer figure 13**

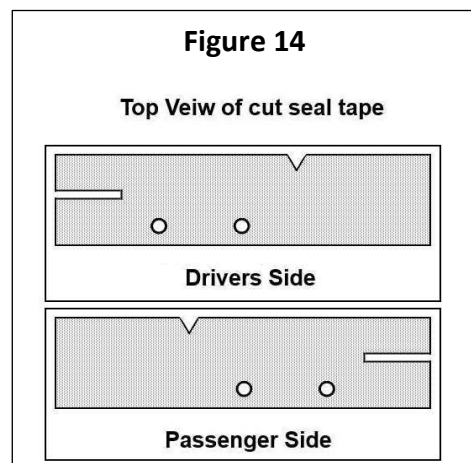

22. Partially peel the backing paper from the driver's side seal.

Align the notched section and the first hole to the vehicle and apply the seal tape to cover the gap between the headboard and the cabin end of the tub. **Refer figure 14**

23. Remove the rest of the backing paper and finish applying the seal.

24. Repeat for Passenger side.

25. Use the remainder of the tape to cover the remaining gap between the center section of the headboard and the cabin end of the tub. Overlap the remaining tape evenly at both ends (approx. 30-40mm). **Refer figure 16**

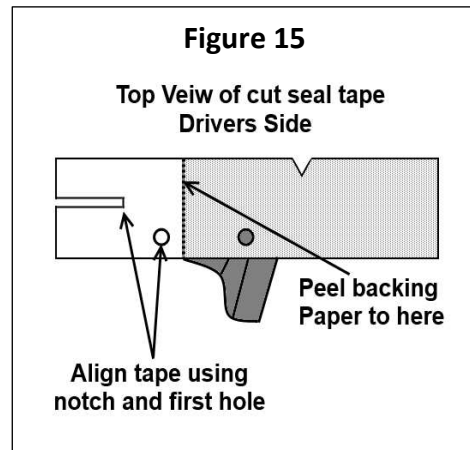
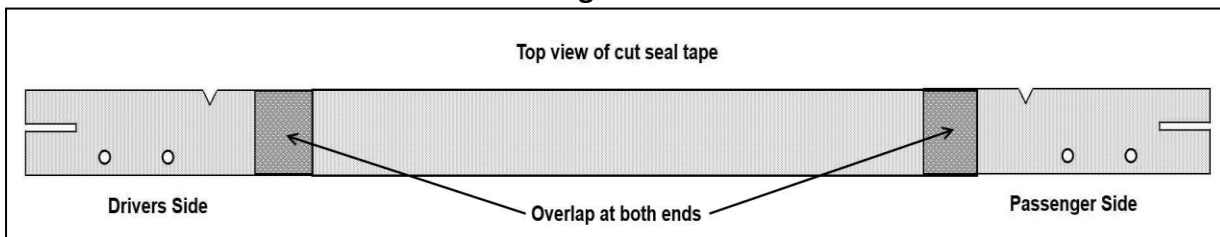

Figure 16



2. CARING FOR YOUR TONNEAU

Apply bee's wax or Dri-lube to the stitching a few times a year, as this will maintain the tonneau's waterproofing ability and prevent the stitching from degrading. Use a mild detergent and soft scrubbing brush to clean tonneau.

Never drive without tonneau support bars in place as the flapping can cause a delaminating effect on the material.

"Tonneau is not designed to be used as a load restraint"

3. MULTI-FIT SUPPORT BAR

The Aussie Tonneau Multi - Fit Support Bar is designed to fit almost all Utes on the Market, from Subaru Brumbys to Cab Chassis aluminium trays.

3.1 BASIC TOOL REQUIRED

- Drill, 4mm drill bit

3.2 MULTI-FIT SUPPORT BAR CONTENTS

- 1 x hollow bar centrepiece
- 2 x grub screws

- 2 x solid bar end piece

3.2 FITTING MULTI-FIT SUPPORT BAR

1. Insert solid bar pieces into either end of hollow tube. Adjust bar so it fits between bar bracket holders with the holes facing to the ground (so the grub screws don't rub against the tonneau), as shown above and then with a white pencil make a mark through the small holes of the hollow bar onto the solid ends. This is where you will drill a hole to the depth of about 1-2mm (do not go any further)
2. Join the pieces back together and screw grub screws through the hollow bar into the holes that you drilled. **Make sure you do not over tighten the grub screws.** Refit the bar. You may kink the bar in the middle to give it some extra height to assist with water runoff.