

Fitting Instruction

Roll Up Soft Tonneau Cover

Part No. AND01767

Ford Next Gen Ranger Dual Cab
With/ Without Sport Bar Model

Installation Instruction

Please note before fitment:







- Read all instructions prior to fitting the Tonneau cover.
- Check that the fitting kit is complete before beginning the installation.
- If replacing any other cover all hardware must be replaced with hardware supplied.

Safety Notes

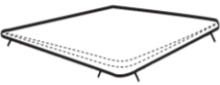
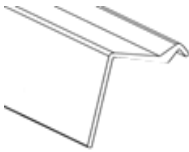

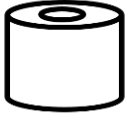

- Ensure that appropriate Personal Protective Equipment is used.
- Always refer to vehicle's work shop manual when removing components.



Parts Supplied

Tonneau Cover x 1	Tailgate Rail x 1	Side Rail x 2	Support Bar x 2	6mm Flange Bolt x 6
				
Spacer x 6	Nylon Nut x 6	Washer x 6		
				

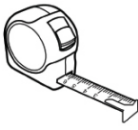
Tools Required

10mm Spanner	4mm Allen Key	Multi-Phillip Head	Tape Measure	Pencil/ Marker
				

1. Final Assembly

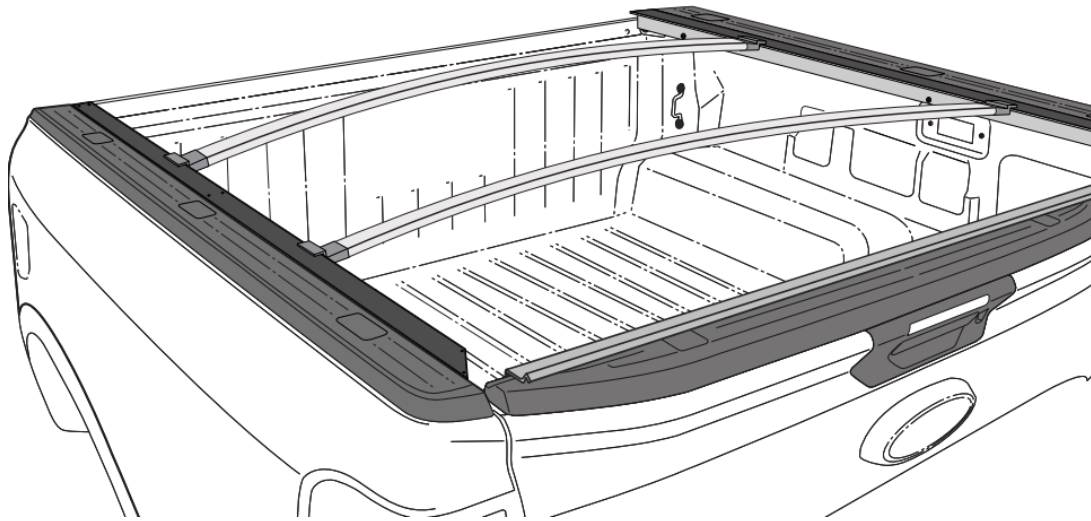

2. Attaching Side Rail

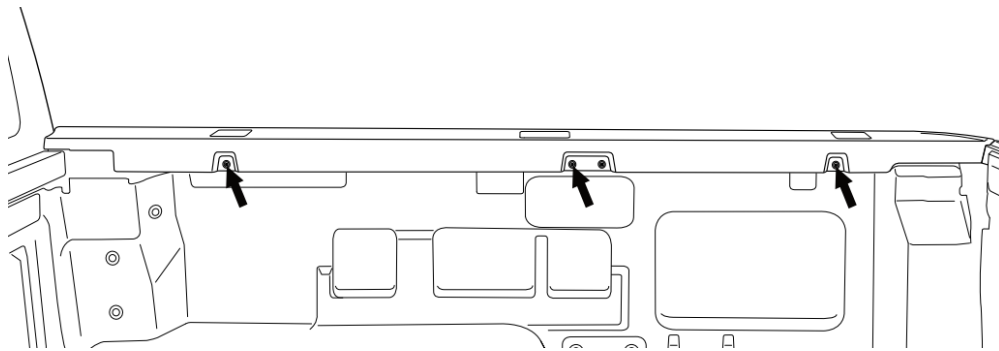

Figure 1

- a. Remove the three factory screws pointed above, using a philips head. *See Figure 1*

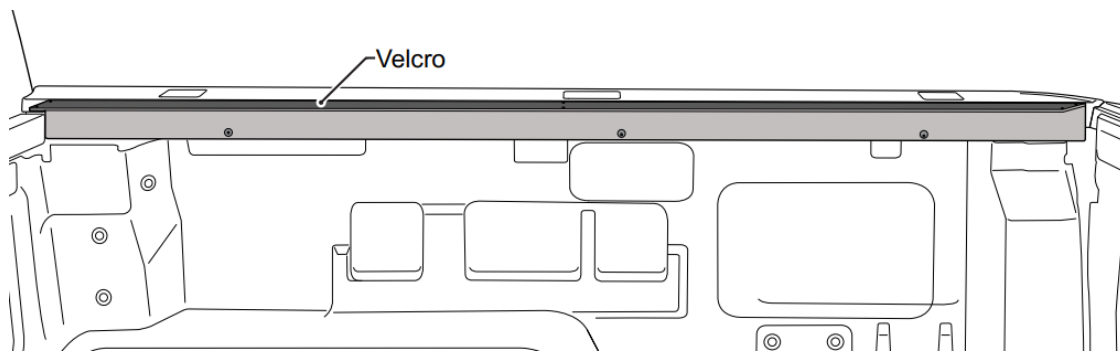

Figure 2

- b. Attach side rail (Angle notch at the rear) with the bolts , spacers , nuts and washer provided in the installation kit, using 4mm hex head and adjustable spanner. *See Figure 2*
- c. The spacers fill the gap behind the rail. *See Figure 3*

Repeat for other side with side rail.

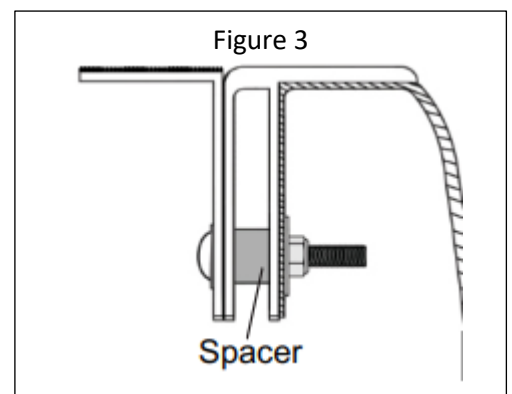

Figure 3

Spacer

3. Attaching Tailgate

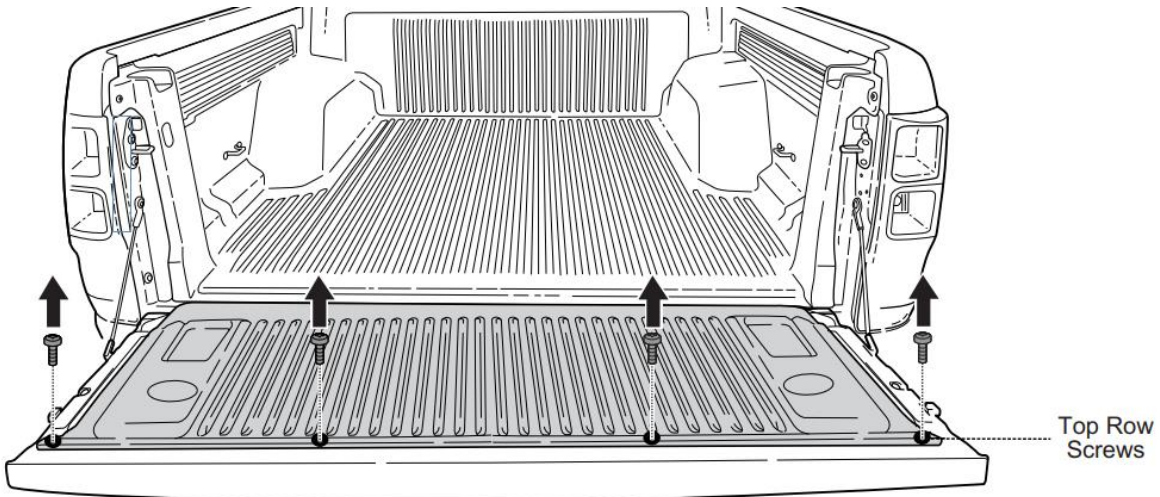

Figure 4

- a. Unscrew the 4 factory screws as shown. The aluminium tailgate rail can go on top of the tailgate liner and the 4 factory screws can be used again to attach the tailgate rail. *See Figure 4*

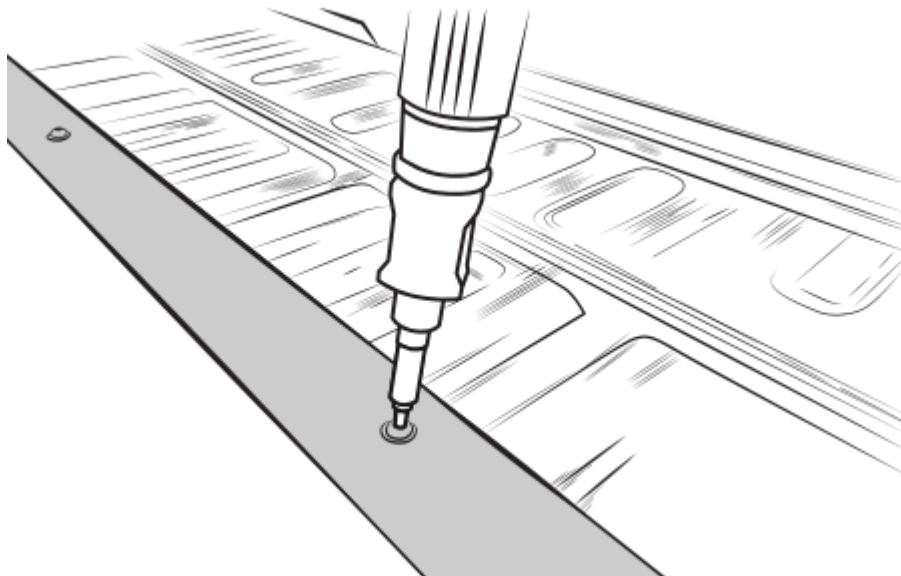

Figure 5

- b. Fit the Tailgate Rail , on top of the tailgate or on top of the tailgate liner if it has one. *See Figure 5*
- c. Place the 4 factory screws back on to secure the tailgate rail. *See Figure 6*

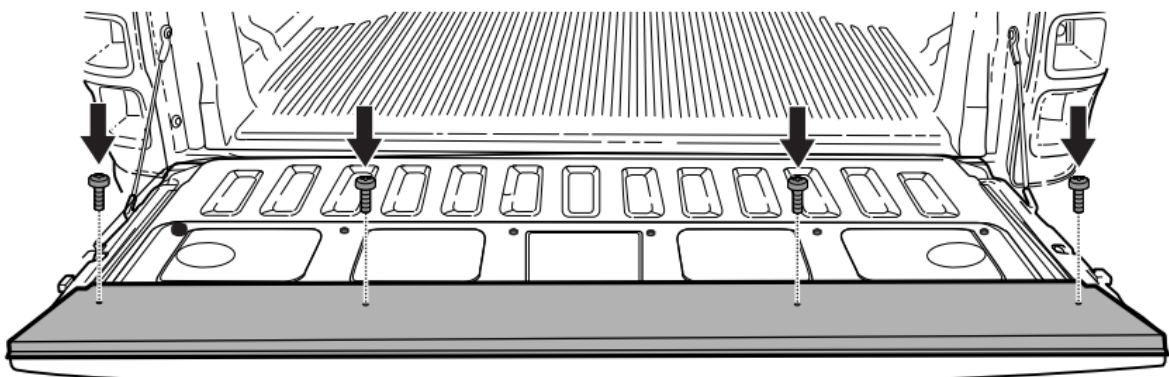

Figure 6

4. Attaching Support Bars

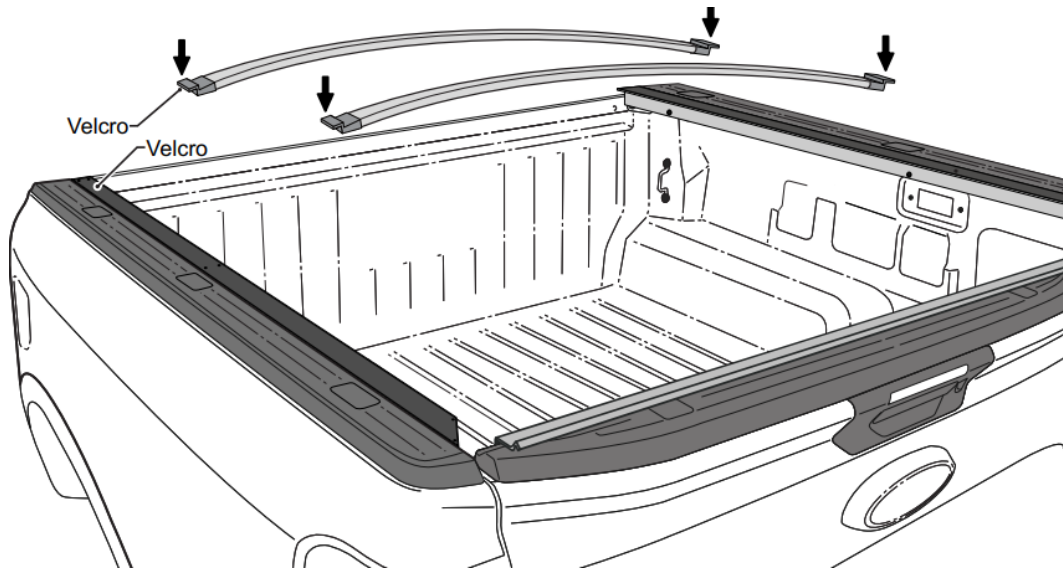

Figure 7

- Mark and place the two Support Bars with even distance from the middle of tub as shown above.
- Velcro on both ends of the Support Bars makes it easy to adjust the distance between them along the velcro surface on the Side Rail and . Adjust them as required. *See Figure 7*
- Make sure the two support bars are seated in place with good velcro contact by pushing lightly on the centre of the two Support Bars. *See Figure 8*

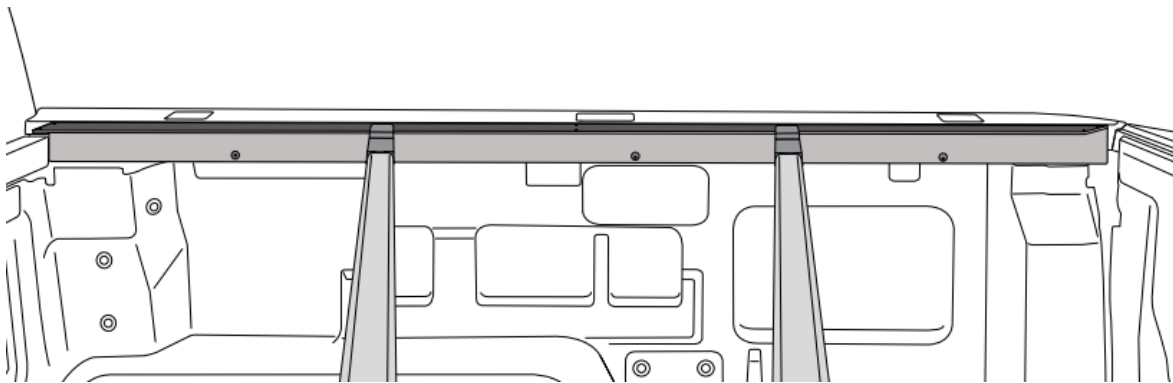

Figure 8

5. Fit The Tonneau Cover

- Attach plastic 'J Retainer' on the front of Tonneau Cover to the front lip of the Ute tub located behind the cab window. *See Figure 9*
- Engage the back of Tonneau Cover frst, followed by the velcro on the sides. Run your hands over the velcro sides, to engage the sides into place.

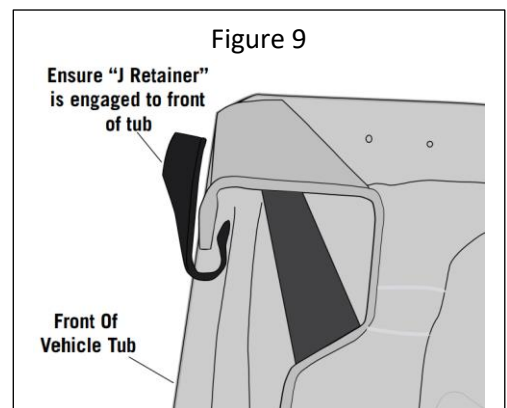
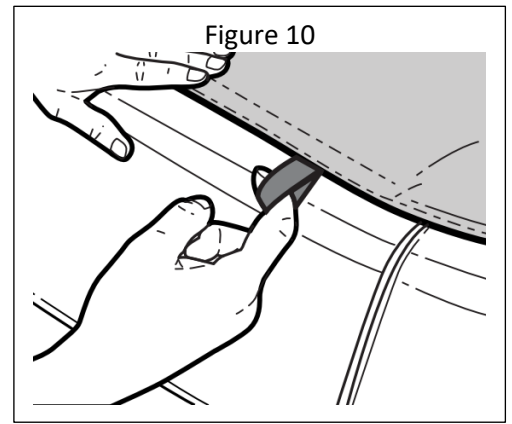

Figure 9

Note: Ensure the support bars are fitted underneath the Tonneau Cover to prevent water ingress and to keep the cover tight.

- c. Use the pull tabs to assist whenever you open or close your cover. *See Figure 10*

Fitment will be tight straight out of the box, but this should loosen up a little after a week or so.



Congratulation! You Have Successfully Installed Your Roll Up Tonneau Cover